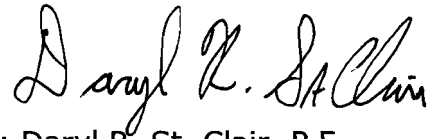

<p>OS-299 (7-08)</p> 	<p>TRANSMITTAL LETTER</p>	<p>PUBLICATION:</p> <p>213 - April 2010 Edition</p> <hr/> <p>DATE:</p> <p>04/01/10</p>
<p>SUBJECT:</p> <p style="text-align: center;">Revisions to Publication 213 "Temporary Traffic Control Guidelines"</p>		
<p>INFORMATION AND SPECIAL INSTRUCTIONS:</p> <p>This replaces Publication 213 date February 15, 2008. Publication 213 dated April 2010 is attached.</p> <p>The following is a list of some important changes.</p> <p> Additions</p> <ul style="list-style-type: none"> a) Table of Contents b) General Notes - 10, 25, 26, 27, 29, 31. Notes 10 and up were renumbered. Note 26 is lighting requirements for flagger stations at night. c) Barrier Stiffenting System drawings d) New PATA 21 Ramp (when working on ramp) e) PATA 26e, new signal figures in accordance with SOL 470-08-6 <p> Revisions</p> <ul style="list-style-type: none"> a) Reference Guide b) General Notes - 9 c) PATA 7 - Heading d) PATA 10a, 10b, 10, (10AFAD's 1, 2 & 3), 13b, 13c, 26a, and 26b - note referring to General Note 26 for illumination of a flagger station at night. e) PATA 10b - changed Note 7 f) PATA 10c, 26b, 26c - changed Note 1b, from 150 ft. to 250 ft. g) PATA 24, added side streets and signing for them h) Appendix A from SOL 470-08-6 <p> Deletions</p> <ul style="list-style-type: none"> a) PATA 11f - removed 		
<p>CANCEL AND DESTROY THE FOLLOWING:</p> <p>Publication 213 dated February 15, 2008</p>	<p>ADDITIONAL COPIES ARE AVAILABLE FROM:</p> <ul style="list-style-type: none"> <input checked="" type="checkbox"/> PennDOT SALES STORE (717) 787-6746 phone (717) 787-8779 fax ra-penndotsalesstore.state.pa.us <input checked="" type="checkbox"/> PennDOT website - www.dot.state.pa.us <i>Click on Forms, Publications & Maps</i> <input checked="" type="checkbox"/> DGS warehouse (PennDOT employees ONLY) 	

APPROVED FOR ISSUANCE BY:

R. Scott Christie, P.E.
Deputy Secretary for Highway
Administration

A handwritten signature in black ink that reads "Daryl R. St. Clair". The signature is written in a cursive style with a large initial 'D' and 'S'.

By: Daryl R. St. Clair, P.E.
Acting Director
Bureau of Highway Safety and Traffic
Engineering

Temporary Traffic Control Guidelines

**PUBLICATION
213
(67 PA CODE, CHAPTER 212)**



Pub 213 (04-10)

Application

Publication 213 applies to contractors; utilities; Federal, State, county, township and municipal governments; and others performing applicable construction, maintenance, emergency or utility/permit work on highways or so closely adjacent to a highway that workers, equipment or materials encroach on the highway or interfere with the normal movement of traffic.

The *Manual on Uniform Traffic Control Devices (MUTCD)* defines the term "temporary traffic control" as: "Temporary Traffic Control Zone - an area of a highway where road user conditions are changed because of a work zone or incident by the use of temporary traffic control devices, flaggers, uniformed law enforcement officers, or other authorized personnel."

The traffic control schemes shown in this publication are normally applicable for both urban and rural areas. Since it is not practical to provide detailed guidelines for all the situations that may conceivably arise, applications are presented for only the most common situations. These are minimum desirable applications for normal situations, and additional protection may be needed when special complexities or potential hazards prevail. The protection prescribed for each situation shall be consistent with the general provisions of *Title 67 Pa. Code, Chapter 212, Official Traffic Control Devices* and the national *Manual On Uniform Traffic Control Devices* as issued by the Federal Highway Administration and should be based on common sense; engineering judgment; the speed and volume of traffic; the duration of the operation; the exposure to potential hazards; the physical features of the highway including horizontal alignment, vertical alignment and the presence of intersections and driveways; and other important factors.

Publication 213

Table of Contents

	<u>Page</u>
Reference Guide	1
General Notes	2 - 5
PATA Sign Layout	6
PATA Barrier Transition	7
Barrier Stiffening	8-9
Act 229	10
PATA Figures	11-105
Appendix A - Reference Guide/Appendix Index	
Appendix B - Temporary Barrier Deflection Distance Table	

Figures for Short Term Operations (24 hours or less)

<u>Figure</u>	<u>Page</u>	<u>Figure</u>	<u>Page</u>
PATA 5	11	PATA 11c	31
PATA 6	12	PATA 11d	32
PATA 7	13	PATA 11e	33
PATA 8	14	PATA 12	34
PATA 9a S	15	PATA 13a	35
PATA 9a L1	16	PATA 13b	36
PATA 9b	18	PATA 13c	37
PATA 9c	19	PATA 14	38
PATA 10a	20	PATA 15	39
PATA 10b	21	PATA 16	40
PATA 10c	22	PATA 17	41
PATA 10d	23	PATA 18	42
PATA 10e	24	PATA 19	43
PATA 10AFAD -1 ...	25 - 26	Blank Page	44
PATA 10AFAD -2 ...	27	PATA 20	45 -46
PATA 10AFAD -3 ...	28	PATA 21	47
PATA 11a	29	PATA 21 Ramps	48
PATA 11b	30	PATA 22	49
		PATA 23	50

Publication 213

Table of Contents (cont'd.)

Figures for Long Term Operations (greater than 24 hours)

<u>Figure</u>	<u>Page</u>	<u>Figure</u>	<u>Page</u>
PATA 9a L2	17	PATA 32	99-100
PATA 24	51	PATA 33	101-102
PATA 25	52	PATA 34	103
PATA 26a	53	PATA 35	104
PATA 26b	54	PATA 36	105
PATA 26c	55	PATA 37	106
PATA 26d	56	PATA 38	107-108
Blank Page	57	PATA 39a	109
PATA 27	92	PATA 39b	110
PATA 28	93	PATA 40	111
PATA 29	94	PATA 41	112
PATA 30	95	PATA 42	113
Blank Page	96		
PATA 31	97-98		

Temporary Traffic Control Signal

<u>Figure</u>	<u>Page</u>	<u>Figure</u>	<u>Page</u>
PATA 26e	58	Blank Page	68
(Reference Guide/ Appendix A Index)		PATA 26e C-1	79-81
PATA 26e M-1	59-62	Blank Page	82
PATA 26e M-2	63-67	PATA 26e C-2.....	83-86
Blank Page	68	PATA 26e L	87-88
PATA 26e NC-1	69-72	PATA 26e PL	89-91
PATA 26e NC-2	73-77		

Appendixes

Appendix A (Temporary Traffic Control Signal Documentation)

Appendix B (Temporary Barrier Deflection Distance Table)

TYPE OF HIGHWAY	CONDITION	FIGURE NUMBER		
		SHORT-TERM OPERATION		LONG-TERM STATIONARY OPERATION
		STATIONARY	MOBILE	
	Work Zone Adjacent to Any Roadway	PATA 5	PATA 6	PATA 24
	Numerous Nighttime Work Zones on or Beyond the Shoulder			PATA 25
	Minor Encroachment	PATA 7		
	Major Encroachment	PATA 8		
TWO-LANE, TWO-WAY HIGHWAYS	Work Zone in the Center of the Roadway	PATA 9a S		PATA 9a L1
	Work Zone in the Left or Right Side of the Roadway			PATA 9a L2
	Work Zone in the Center of an Intersection	PATA 9b		
	Surveying Along Centerline of Road with Low Traffic Volumes	PATA 9c		
	Flagging	PATA 10a	PATA 11a*	PATA 26a
	Intersection Flagging	PATA 10b		
	Single Flagger	PATA 10c	PATA 11b*	PATA 26b
	Stop Sign-Controlled Lane Closure	PATA 10d		PATA 26c
	Self-Regulating Lane Closure	PATA 10e		PATA 26d
	Flagger at One End, AFAD at the Other End	PATA 10AFAD-1		
	AFAD With Flagger at Both Ends	PATA 10AFAD-2		
	AFAD At Both Ends, Single Flagger Centrally Located	PATA 10AFAD-3		
	Road Closure	PATA 11d*, 11e*	PATA 11c*	
	Moving Lane Closure		PATA 12	
	Temporary Traffic Control Signals	PATA 26e - Reference Guide for Temporary Traffic Control Signals		
	Temporary Roadway			PATA 27
THREE-LANE, TWO-WAY HIGHWAYS WITH PASSING	Work Zone in the Single-Lane Approach	PATA 13a	PATA 12	PATA 28
	Work Zone in Both Lanes of the Two-Lane Approach	PATA 13b		
	Work Zone in One-Lane Approach and Left Lane of Two-Lane Approach	PATA 13c		
	Work Zone in the Left or Right Lane of the Two-Lane Approach	PATA 16	PATA 16, 23	PATA 31
THREE-LANE, TWO-WAY HIGHWAYS WITH A CENTER LANE, LEFT TURN ONLY PATTERN	Work Zone in One of the Through Lanes	PATA 14	PATA 12	PATA 29
	Work Zone in the Two-Way Left Turn Lane	PATA 15	PATA 15	PATA 30
OTHER MULTILANE, UNDIVIDED HIGHWAYS	Work Zone in the Left or Right Lane	PATA 16	PATA 16, 23	PATA 31
	Work Zone in the Center Lane of a Three-Lane Approach	PATA 19	PATA 23	PATA 34
	Work Zone Requiring the Closure of One Side of a Four-Lane Undivided Highway	PATA 17		PATA 32
	Work Zone in a Two-Way Left Turn Lane	PATA 15	PATA 15	PATA 30
DIVIDED OR ONE-WAY HIGHWAY	Work Zone in the Left or Right Lane	PATA 18	PATA 18, 23	PATA 33
	Work Zone in the Center Lane of a Three-Lane, One-Way Roadway	PATA 19	PATA 23	PATA 34
	Work Zone in Two Adjacent Lanes	PATA 20		PATA 35
	Lane Closure Near a Freeway or Expressway Exit Ramp	PATA 21		PATA 36
	Lane Closure Near a Freeway or Expressway Entrance Ramp	PATA 22		PATA 37
	Work Zone in a Ramp	PATA 21 Ramp		
	Two-Way Traffic on One Roadway of a Normally Divided Highway			PATA 38
	Detour of a Numbered Traffic Route			PATA 39a
	Detour of an Unnumbered Traffic Route			PATA 39b
	Sidewalk Detour or Diversion			PATA 40
	Crosswalk Closures and Pedestrian Detours			PATA 41
	Temporary Bituminous Rumble Strip Patterns			PATA 42

Short-Term Stationary Operation -- Work that occupies a location up to 24 hours. * Daylight Only
 Long-Term Stationary Operation -- Work that occupies a location more than 24 hours.
 Mobile Operation -- Any operation that moves intermittently or continuously.

REFERENCE GUIDE FOR TYPICAL FIGURES

PUBLICATION 213
GENERAL NOTES, TABLES AND LEGEND

GENERAL NOTES

1. All distances may be adjusted slightly to fit field conditions.
2. All signs shall be 36" x 36" for conventional roadways and 48" x 48" for expressways and freeways unless otherwise noted.
3. Traffic Control Plans may deviate from the typical applications shown in this publication to allow for conditions and requirements of a particular site or jurisdiction.
4. The three categories for work duration of temporary traffic control are:
 - a. Short-Term Stationary Operation - Work that occupies a location up to 24 hours.
 - b. Long-Term Stationary Operation - Work that occupies a location more than 24 hours.
 - c. Mobile Operation - Work that moves intermittently or continuously.
5. The EMERGENCY AHEAD (W25-1), SURVEY CREW (W21-6), MOWING NEXT () MILES (W21-14) and BRIDGE INSPECTION AHEAD (W21-11) signs may be used as an alternate to the ROAD WORK AHEAD sign (W20-1) or ROAD WORK NEXT () MILES (620-1) where appropriate.
6. The needs and control of all road users through the work zone (including motorists, bicyclists, pedestrians and persons with disabilities in accordance with the Americans with Disabilities Act of 1990) shall be an essential part of highway construction, utility work, maintenance operations, and the management of traffic incidents.
7. Sign sheeting shall be of an approved type and listed in Publication 35 (Bulletin 15). Sheeting for freeways and expressways shall be fluorescent orange.
8. All warning sign colors shall have orange background and black border and legends unless otherwise specified.
9. All workers including flaggers shall wear a high-visibility fluorescent orange or yellow-green apparel with retroreflective material that meets the latest ANSI/ISEA publication entitled American National Standard for High-Visibility Safety Apparel and Headwear for Class 2 risk exposure anytime day or night. Class 3 high-visibility apparel should be considered for additional flagger visibility at night. During inclement weather, high-visibility fluorescent rain gear may be used. If FHWA amends or modifies their regulation, the amendment will take effect on the date specified by FHWA.

Worker -

A person on foot whose duties place him or her within the right-of-way of a street or highway, such as highway construction and maintenance forces, survey crews, utility crews, responders to incidents within the street or highway right-of-way, and law enforcement personnel when directing traffic, investigating crashes, and handling lane closures, obstructed roadways, and disasters within the right-of-way of a street or highway.

Emergency and incident responders and law enforcement personnel within the TTC zone may wear High-Visibility Public Safety Vests that meets the performance requirements of the ANSI/SEA 207-2006 (see Section 1A.11), or equivalent revisions, and labeled as ANSI 207-2006, in lieu of ANSI/ISEA 107-2004 apparel.













All flaggers at minimum shall have training as per the most current version of Publication 408, Section 901.3 Flagger Training.

For guidrail deflection distances refer to PUB 13M (DM-2) Design Manual 2 in Chapter 12 Table 12.3 (English) Guide Rail and Median Barrier Systems page 12-10 and for temporary barrier see Appendix B.

A second shadow vehicle with a truck mounted attenuator shall be used when directed by the Assistant District Executive for Maintenance for bridge inspection teams while on limited access highway bridges.

Orange flags or flashing warning lights may be used in conjunction with signs.

LEGEND

-  Work space
-  Sign
-  Channelizing device
-  Shadow vehicle with a flashing or revolving yellow light
-  Direction of travel
-  Normal Speed Limit in advance of the work zone
-  Taper length
-  Type B Light
-  Type III Barricade
-  Flashing Arrow Panel
-  Automated Flagger Assistance Device
-  Flagger with a W21-10 Sign, a protective helmet, and a (high visibility) safety vest

GENERAL NOTES (CONTINUED)

14. Traffic Cones shall only be used during short term operations.

15. Definitions:

- a. Urban Street - A type of street normally characterized by relatively low speeds, wide ranges of traffic volumes, narrower lanes, frequent intersections and driveways, significant pedestrian traffic, and more businesses and houses.
- b. Expressway - A divided arterial highway for through traffic with partial control of access and generally with grade separations at major intersections.
- c. Freeway - A limited access highway to which the only means of ingress and egress is by interchange ramps.
- d. Buffer Space - A space clear of equipment, vehicles, workers or materials as shown on figures as distance E.
- e. Roll Ahead Space - Provide a 100' to 250' space between the shadow vehicle and the work space in a closed lane
This space shall be clear of equipment, vehicles, materials or workers.
- f. Shadow vehicle - A vehicle positioned in the activity area in the advance of a work vehicle to provide advance information to approaching drivers or protection for the workers or work vehicle.

16. Equipment, vehicle and material storage.

- (1) Except as indicated in paragraph (2), at the end of the workday, and whenever practical during the workday, based on actual site conditions, equipment, vehicles and material shall be stored a minimum of 30 feet from the edge of the nearest open travel lane or they shall be adequately stored behind a longitudinal (including guiderail) barrier, or more than 2 feet behind the curb. Design Manual 2, Chapter 12, Table 12.3 presents minimum unobstructed distances that shall be maintained behind various guiderail systems and refer to Appendix B for temporary barrier deflection distances.
- (2) If site conditions prevent equipment, vehicles and material from being stored as indicated in paragraph (1), or if these items are placed for use or operation on or near the highway surface within the work zone, then barricades, drums or other protective devices shall be placed around the equipment, vehicles and material storage site, to warn and protect the traveling public consistent with this publication.
- (3) Workers are not permitted to park their vehicles within the highway right-of-way in a manner that compromises the safety of workers, pedestrians or the travelling public.

17. Neither work activity nor storage of equipment, vehicles, or material should occur within a buffer space.

18. Guidelines for installation and removal of traffic control setups.

- (a) Required advance warning signs should be installed first so that protection is provided when channelizing devices are installed near the work area. If work zone signing is necessary for both directions of travel, sign installation should begin with the advance warning sign located furthest from the work area and on the side of the roadway opposite the work area, sign installation should proceed down the roadway toward the work area. After the necessary signs are erected on the side of the roadway opposite the work area, sign installation may begin for the other direction of travel, beginning with the sign furthest from the work area. In the process of installing the work zone signing, existing signs with conflicting messages shall be completely covered, removed or modified.
- (b) If the work area is such that flagging operations are necessary, the flaggers may begin flagging operations after the advance warning signs are in place. Otherwise, the installation of channelizing devices at the work area can begin after the placement of the advance warning signs. These devices should also be installed in the direction of travel.
- (c) If available, a shadow vehicle may be placed between approaching traffic and the workers who are installing channelizing devices around the work area. After channelizing devices are installed, the vehicle may be removed or moved inside the work area and work may begin.
- (d) After work is completed, the work zone traffic control scheme may be dismantled. The channelizing devices which surround the work site should be removed first, in reverse order as it was installed (opposite the flow of traffic), followed by flaggers which may have been used. The work area signing may then be removed and normal traffic patterns restored.

GENERAL

PUBLICATION 213
GENERAL NOTES, TABLES AND LEGEND

GENERAL NOTES (CONTINUED)

19. As a general rule, signs shall be located on the right-hand side of the roadway. On divided highways and one-way highways where it is physically possible, signs should also be placed on the left-hand side of the roadway. (See PATA Sign Layout Figure)
20. Please refer to Publication 408, Section 901.3 (j) for traffic control requirements adjacent to pavement edge or shoulder dropoffs during construction.
21. Portable Sign Stands should not be used for a duration of more than 3 days.
22. A three cone advance setup may be used to alert oncoming traffic of a flagger during a flagging operation. This three cone advance setup, when used, is in addition to the traffic control setup being used at the time. The three cone advance setup is located in the center of the roadway. The three cone advance setup should be located at a distance from 150 feet in advance of the flagger or a distance no greater than the W20-7A sign. Each cone in the 3-cone setup shall be spaced between 10 to 50 feet apart as shown in the following figure:

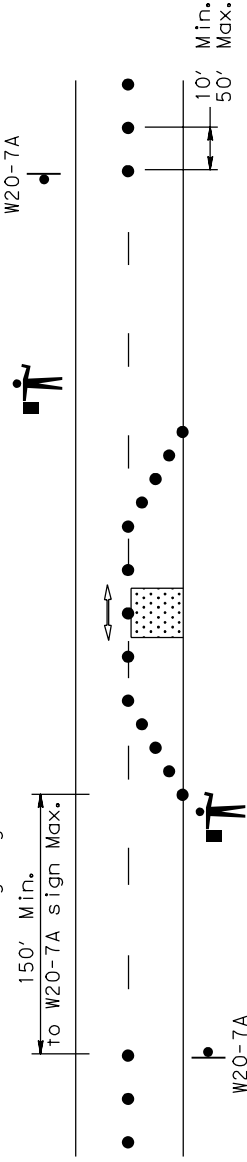

23. When used with a truck-mounted attenuator (TMA), the shadow vehicle must be loaded to the weight recommended by the manufacturer of the TMA.
24. Shadow Vehicles for mowing operations are optional.
25. Because flaggers are responsible for public safety and make the greatest number of contacts with the public of all highway workers, they should be trained in safe traffic control practices and public contact techniques. Flaggers should be able to satisfactorily demonstrate the following abilities:
 - a. Ability to receive and communicate specific instructions clearly, firmly, and courteously.
 - b. Ability to move and maneuver quickly in order to avoid danger from errant vehicles, this means a flagger shall not be in a sitting position and no vehicles around the flagger station.
 - c. Ability to control signaling devices (such as paddles and flags) in order to provide clear and positive guidance to drivers approaching a TTC zone in frequently changing situations.
26. Except in emergency situations, each flagger station shall be illuminated at night with an overhead lighting source having 30,000 to 40,000 lumens minimum of light output for an area of not less than 7,500 square feet. The lighting source shall have a minimum color temperature of 3,000 degrees and a maximum of 4,000 degrees. Position the light so the flaggers can be seen and not cause excessive glare to motorists traveling through the work zone.
27. A red flag shall only be used in an emergency when a Stop/Slow Paddle is not available or at intersections where a single flagger is used within the intersection. Additional flaggers shall be used to help control traffic movements at all times. When flagging at a signalized intersection, the signal should be placed in flash mode. If necessary, provide additional flaggers to properly control all movements of the intersection. In locations where multiple signalized intersections are located in close proximity, multiple intersections may be placed in flash mode to control the traffic flow through the work zone. Additional flaggers shall be used to control the traffic movements through each intersection.
28. See MUTCD chapter 6 and Publication 212 for additional guidelines and requirements.
29. Provisions and guidelines governing temporary traffic control for emergency work and incident management are given in Title 67 Pa. Code Chapter 212, Official Traffic Control Devices, §212.414 and in Chapter 6I in the MUTCD.
30. Consider using temporary longitudinal barrier to protect workers in all freeway and multi-lane work zones if the speed limit is 45 mph or greater, workers are present within one lane width of a active travel lane and a lane or shoulder is closed 24 hours per day for more than 2 weeks.
31. On roadways where the normal posted speed is greater than 50 mph and has more than one lane of traffic in the same direction approaching the work zone, install additional signing when traffic queues go beyond the advance signing. As needed, install additional signing such as but not limited to Road Work, xxx Lane Closed, Work Zone Speed Limit and/or portable changeable message boards.

TABLE 1.
FORMULAS FOR DETERMINING
TAPER LENGTHS

S	W	L
40 MPH or less	$L = \frac{WS^2}{60}$	L
45 MPH or more	$L = WS$	L

W = width of offset in feet

TABLE 2.
MERGING TAPER LENGTH

S	W	L
25	10	100
	11	110
	12	130
30	10	150
	11	170
	12	180
35	10	200
	11	220
	12	250
40	10	270
	11	290
	12	320
45	10	450
	11	500
	12	540
50	10	500
	11	550
	12	600
55	10	550
	11	610
	12	660
60	10	600
	11	660
	12	720
65	10	650
	11	720
	12	780

W = width of offset in feet

S = Normal Posted speed Limit
in Calculating Taper Lengths

TABLE 3.
OTHER TAPER LENGTHS

Type of Taper	L
Merging Taper	L Min.
Shifting Taper	0.5L Min.
Shoulder Taper	0.33L Min
One-Lane, Two-Way Traffic Taper	100' Max.
Downstream Taper	100' Max./Lane

TABLE 4.
ADVISORY SPEED FOR FREEWAYS AND EXPRESSWAYS

S	Work Area Speed Limit	Signs from Beginning of Work Area				Advisory Speed *** In Advance of the Work Area
		4th	3rd	2nd	1st	
65	55		55	55	55	
65	50*	55	55	50	50	
65	45*	55	50	45	45	
55	45	50	50	45	45	
55	40*	50	45	40	40	
55	35*	50	45	40	35	
50	40	45	45	40	40	
50	35*	45	40	35	35	
50	30*	45	40	35	30	
45	35	-	40	35	35	
45	30*	-	40	35	30	
45	25*	-	35	30	25	
40	30	-	35	30	30	
40	25*	-	35	30	25	

*** The use of advisory speed plaques are optional.





* Work area speed limits less than 25 MPH or a reduction of more than 10 MPH below the normal speed limit should be used only when required by restrictive features in the work zone and require prior approval. See Publication 212 for further guidelines.

TABLE 5.
FLASHING ARROW PANEL GUIDELINES

Panel Type	Size (inches)	Application
A**	48x24	Low-speed urban Typically 25-30 MPH
B**	60x30	Intermediate-speed facility, typically 35-40 MPH and Mobile Operations
C**	96x48	Freeway and Expressway Other high-speed, high-volume roadways Typically 45 MPH or greater
D**	Length of Arrow=48 Width of Arrowhead=24	Low-speed urban, typically 25-30 MPH Short-term work not to exceed one daylight period For use on authorized vehicles only

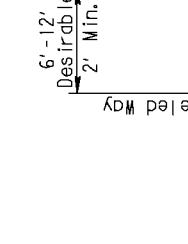
** Type A, B and C arrow panels shall have solid rectangular appearances. The Type D arrow panel shall conform to the shape of the arrow.

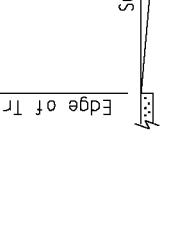
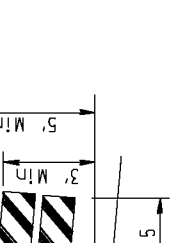
PUBLICATION 213
GUIDELINES FOR HEIGHT AND LATERAL PLACEMENT
FOR WORK ZONE SIGNS

POST MOUNTED SIGNS	SIGNS MOUNTED ON TYPE III BARRICADES	SIGNS MOUNTED ON PORTABLE SUPPORTS (See Note 7)
<p>RURAL AREAS</p> 		
<p>URBAN AREAS</p> 		
<p>NOTES</p>	<ol style="list-style-type: none"> 1. Signs located on both the left and right sides of a roadway shall conform with these guidelines. 2. Higher mounting heights are desirable and may be necessary where construction equipment, material, or other obstructions such as parking or pedestrian activity are present. 3. In urban areas, a clearance of 1' from the curb face is permissible where sidewalk width is limited or where existing poles are close to the curb. 4. Within work zones, it is sometimes necessary or desirable to position signs within the roadway itself. All signs erected within a roadway or a shoulder shall be mounted on portable supports or Type III barricades. 5. The length of Type III barricade rails shall equal or exceed the widest horizontal dimension of the widest sign installed on the barricade or a minimum of 4' which ever is larger. 6. The supplemental plaque may also be centered under the sign. 7. Portable sign support shall only be used during short term operation. 	

PUBLICATION 213
32" TO 50" CONCRETE BARRIER TRANSITION

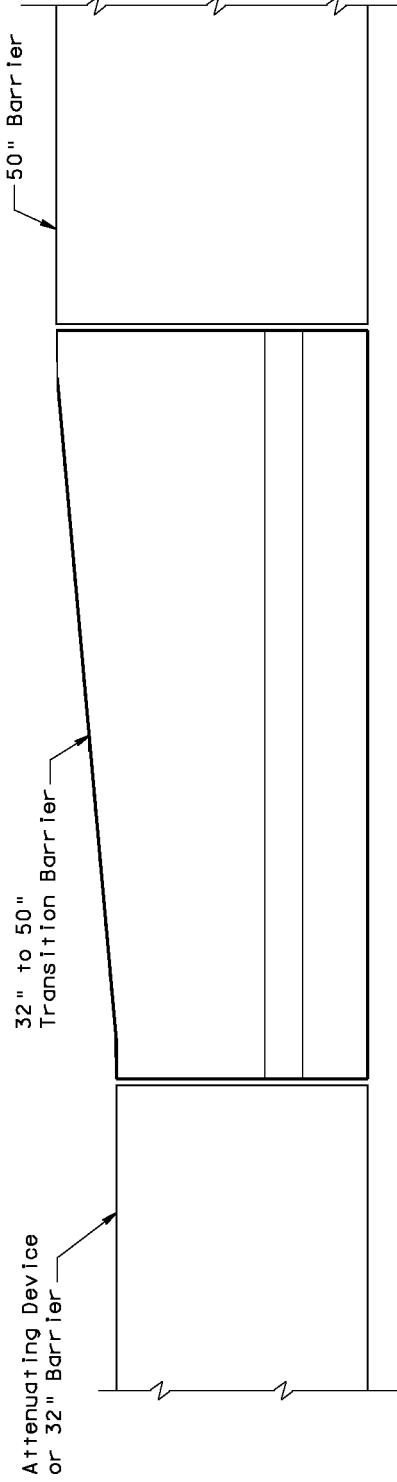

ELEVATION

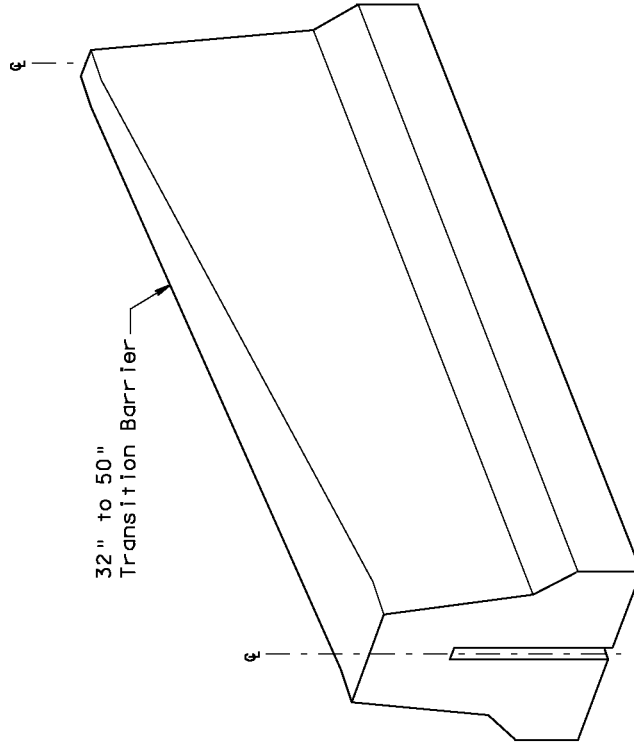

ORTHOGRAPHIC VIEW

- Notes:
1. Transition must be used when the following exist:
 - a) When an attenuating device is used to shield blunt end of 50" high barrier.
 - b) When transitioning from 50" to 32" high barrier.

2. See RC-57M, sheet 6 in PennDot Standards (Pub 72M) for additional details.

PATA
Barrier Transition

PUBLICATION 213
LATERAL PLACEMENT OF BARRIER IN A DROPOFF CONDITION

CONDITION - BDD IS LESS THAN OR EQUAL TO LS

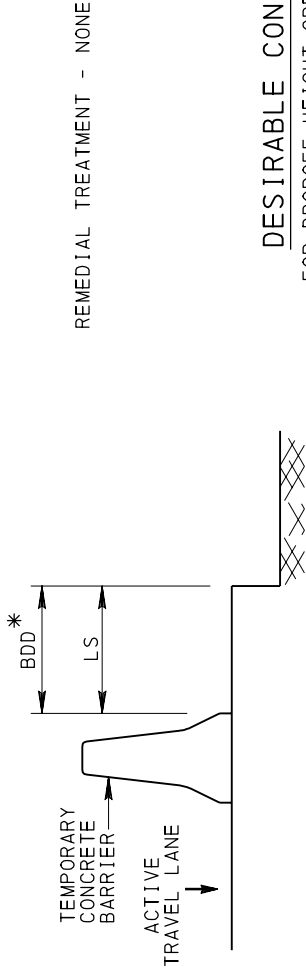

DESIRABLE CONDITION

FOR DROPOFF HEIGHT GREATER THAN 2 "

CONDITION - BDD IS GREATER THAN LS AND DROPOFF IS LESS THAN 6 "

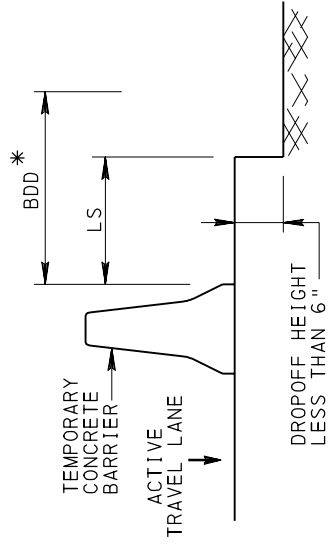

REMEDIAL TREATMENT - NONE

NOTE: THIS CONDITION IS ONLY PERMISSABLE WHEN THE DROPOFF IS LESS THAN 6 " AND THE WORK ZONE SET-UP HAS BEEN THOROUGHLY REVIEWED TO MAXIMIZE THE LS.

CONDITION - BDD IS GREATER THAN LS AND DROPOFF IS EQUAL TO OR GREATER THAN 6 "

BARRIER STIFFENING REQ'D.,
SEE DETAILS ON SHEET 2.

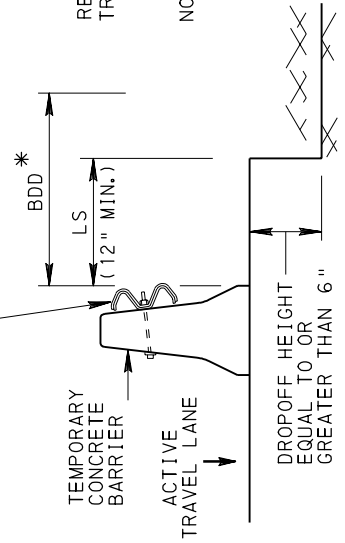

REMEDIAL TREATMENT -

STIFFEN TEMPORARY CONCRETE BARRIER WITH W-BEAM CUT IN HALF, THEN NESTING THE 2 HALVES AS SHOWN ON SHEET 2.

NOTE: OTHER METHODS TO LIMIT THE BDD MUST BE APPROVED BY THE BUREAU OF DESIGN.

LEGEND

- BDD - BARRIER DEFLECTION DISTANCE
- LS - LATERAL SPACE-DISTANCE REQUIRED BEHIND TEMPORARY CONCRETE BARRIER TO ACCOMODATE BARRIER DEFLECTION.
- * - FOR DEFLECTION DISTANCE OF VARIOUS APPROVED BARRIERS, SEE PUB. 213, APPENDIX B, "TEMPORARY BARRIER DEFLECTION DISTANCES TABLE".

SHEET 1 OF 2

PATA
Barrier Stiffening

PUBLICATION 213
LATERAL PLACEMENT OF BARRIER IN A DROPOFF CONDITION

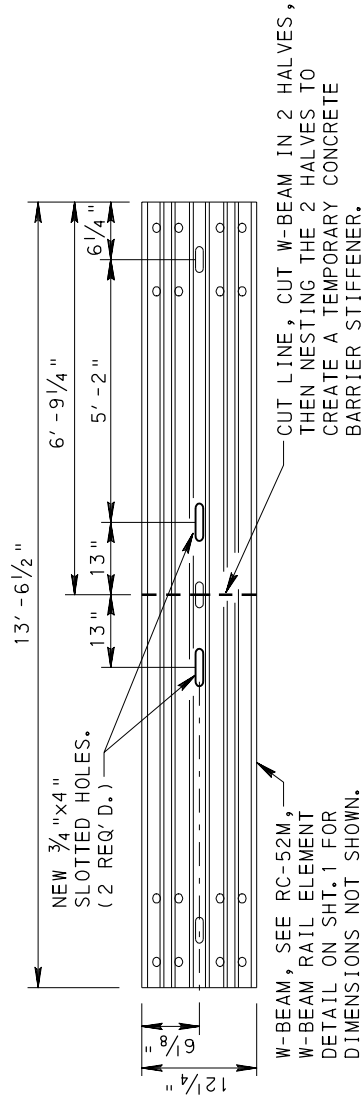

STIFFENER FABRICATION DETAIL

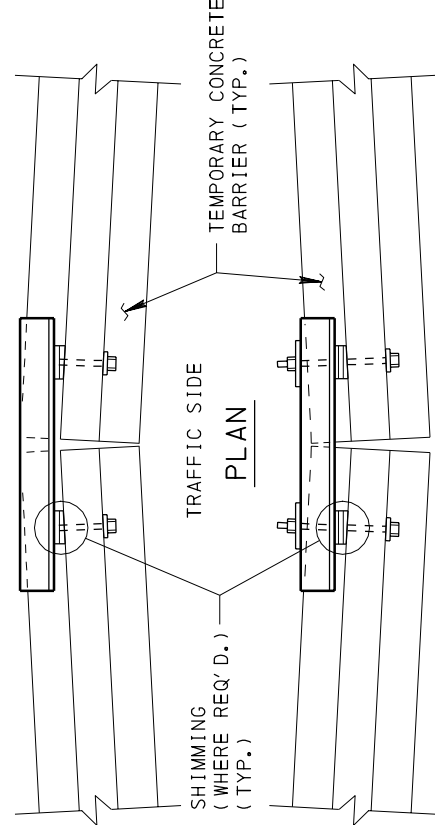
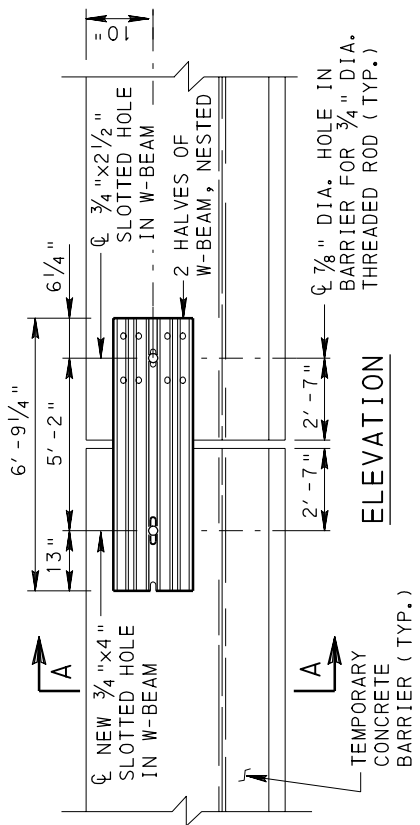
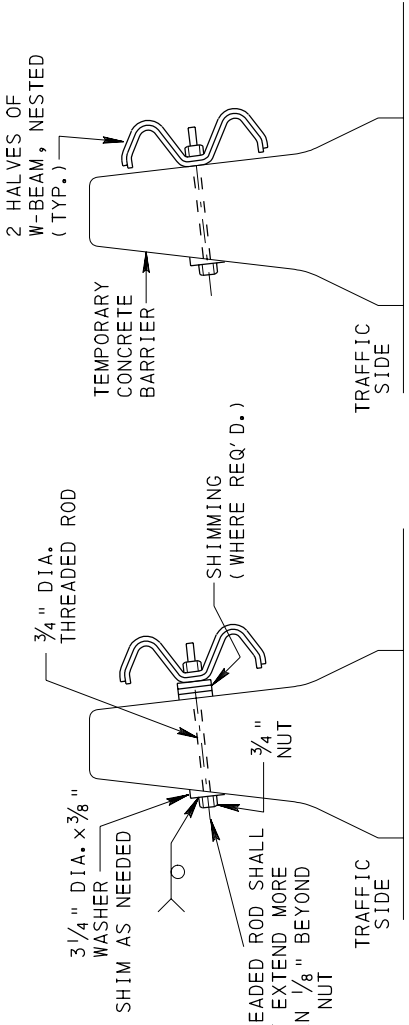

TEMPORARY CONCRETE BARRIER STIFFENING

NOTES:

1. STIFFENED BARRIER WALL IS REQUIRED IN WORK ZONES WHEN BARRIER WALL IS LOCATED WITHIN THE DEFLECTION DISTANCE OF THE BARRIER AS SHOWN IN PUBLICATION 213, APPENDIX B, "TEMPORARY BARRIER DEFLECTION DISTANCES TABLE".
2. STIFFENER SHALL BE INSTALLED WHEN BARRIER IS SET AND BEFORE ROADWAY IS OPEN TO TRAFFIC OR PIOR TO DROPOFF CONDITION BEING EXPOSED IN WORK ZONE.
3. PROVIDE MATERIALS AND CONSTRUCTION MEETING THE REQUIREMENTS OF PUBLICATION 408, SECTIONS 620 AND 1109.
4. WHEN BARRIERS ARE PLACED ON A RADIUS, THE AREA BETWEEN THE W-BEAM AND BARRIER WALL SHALL BE SHIMMED AS SHOWN ABOVE.
5. ALL MATERIALS AND LABOR INVOLVED WITH THIS BARRIER STIFFENER SYSTEM SHALL BE PAID AS A SEPARATE PAY ITEM.
6. SHIM SHALL CONSIST OF ONE SQUARE PLATE 3/16" THICK WITH AS MANY 3/4" DIA. x 3/8" THICK WASHERS AS NEEDED.
7. ROD PERPENDICULAR TO BARRIER WALL SURFACE (TYP.) ON THE WORK ZONE SIDE OF THE BARRIER.

PUBLICATION 213
 SHORT-TERM STATIONARY OPERATION
 ADJACENT TO ANY ROADWAY

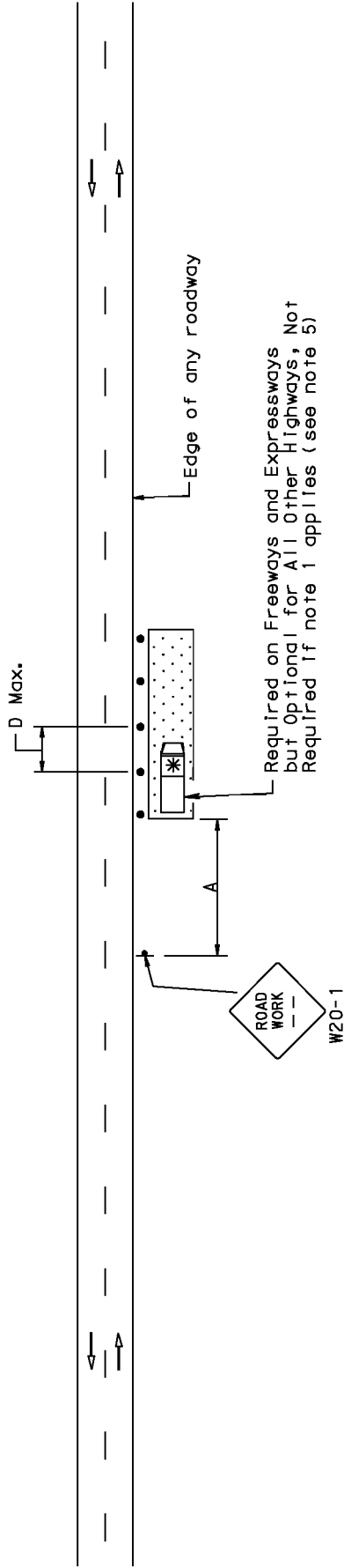

<p>CONDITION 1: All Highways (except Freeways and Expressways) A = 500 ft., W20-1 sign distance plaque to read 500 ft. or "AHEAD" D = 2 times the normal speed limit</p>
<p>CONDITION 2: For Urban Streets A = 200 ft. and sign distance plaque to read "AHEAD" D = 2 times the normal speed limit</p>
<p>CONDITION 3: For Freeways and Expressways A = 1000 ft., W20-1 sign distance plaque to read 1000 ft. or "AHEAD" D = 2 times normal speed limit</p>

NOTES

1. Traffic control devices are not required if the work space is outside the highway right-of-way, behind barrier, more than 2' behind curb, or 15' or more from the edge of any roadway.
2. For divided highways and one-way highways where it is physically possible, advance warning signs should also be placed on the left-hand side of the roadway.
3. The W20-1 Sign may be replaced with other appropriate signs (Low Shoulder sign, No Guide Rail sign, and so forth).
4. For operations 60 minutes or less, all traffic control devices may be eliminated if a vehicle with an activated flashing or revolving yellow light is used.
5. Shadow vehicle shall be equipped with a Truck Mounted Attenuator (TMA) on Expressways and Freeways. Use of a TMA is Optional on all other Highways when a shadow vehicle is used.

PUBLICATION 213
 SHORT-TERM MOBILE OPERATION
 ADJACENT TO ANY ROADWAY

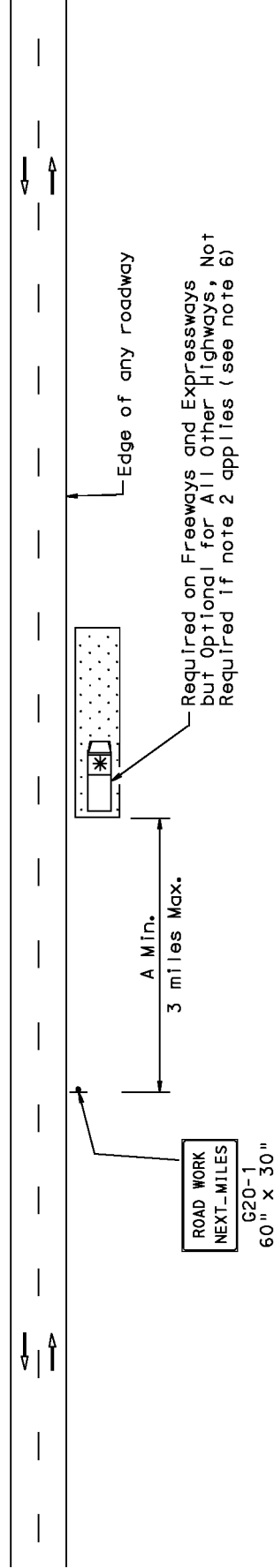

CONDITION 1: All Highways (except Freeways and Expressways)
 A = 500 ft.

CONDITION 2: For Urban Streets
 A = 200 ft. and sign distance plaque to read "AHEAD"

CONDITION 3: For freeways and expressways
 A = 1000 ft.

NOTES

1. This figure applies for operations that move intermittently or continuously at an average speed of more than 1 MPH (88 ft/min).
2. Traffic control devices are not required if the work space is outside the highway right-of-way, behind barrier, more than 2' behind curb, or 15' or more from the edge of any roadway.
3. For divided highways and one-way highways where it is physically possible, advance warning signs should also be placed on the left-hand side of the roadway.
4. For operations 60 minutes or less, all traffic control devices may be eliminated if a vehicle with an activated flashing or revolving yellow light is used.
5. For a work area greater than 3 miles, a second G20-1 sign may be installed at the end of the first 3 mile segment.
6. Shadow vehicle shall be equipped with a Truck Mounted Attenuator (TMA) on Expressways and Freeways. Use of a TMA is optional on all other Highways when a shadow vehicle is used.

PUBLICATION 213
 SHORT-TERM STATIONARY OPERATION
 ALL ROADWAYS EXCEPT FREEWAYS AND EXPRESSWAYS - MINOR ENCROACHMENT

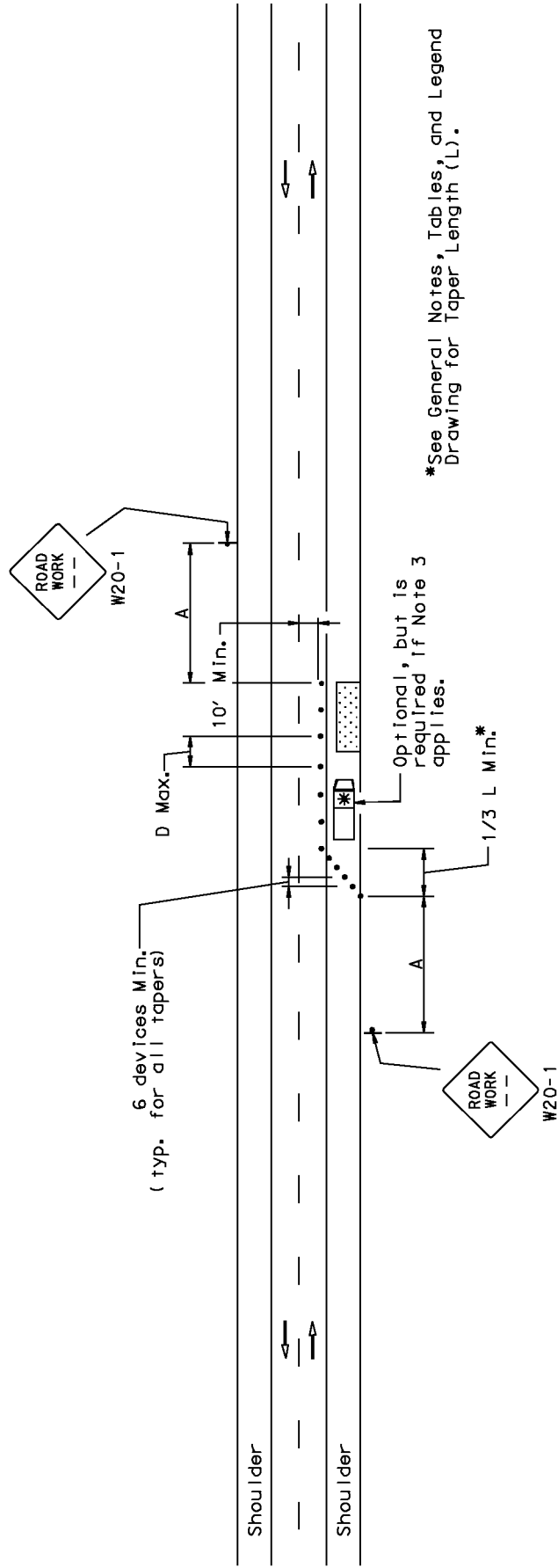

*See General Notes, Tables, and Legend Drawing for Taper Length (L).

Distance plaques on Advance Warning signs shall be the same series type.
 Example: either all XXX ft. or all "AHEAD"
 CONDITION 1: All Highways (except Freeways and Expressways)
 A = 500 ft., W20-1 sign distance plaque to read 500 ft. or "AHEAD"
 D = 2 times the normal speed limit
 CONDITION 2: For Urban Streets
 A = 200 ft. and sign distance plaque to read "AHEAD"
 D = 2 times the normal speed limit

NOTES

1. If the work area is completely within a parking lane and parking is present, the taper or the vehicle with an activated or revolving yellow light is not required.
2. When paved shoulders having a width of 8' or more are closed, channelizing devices should be used to close the shoulder.
3. For operations of 15 minutes or less
 - a. The W20-1 Sign is not required.
 - b. All channelizing devices may be eliminated if a vehicle with an activated flashing or revolving yellow light is present in advance of the work space.
4. Additional signs may be appropriate (Road Narrows sign, No Guide Rail sign, and so forth).

PUBLICATION 213
 SHORT-TERM STATIONARY OPERATION
 TWO-LANE, TWO-WAY ROADWAY - MAJOR ENCROACHMENT

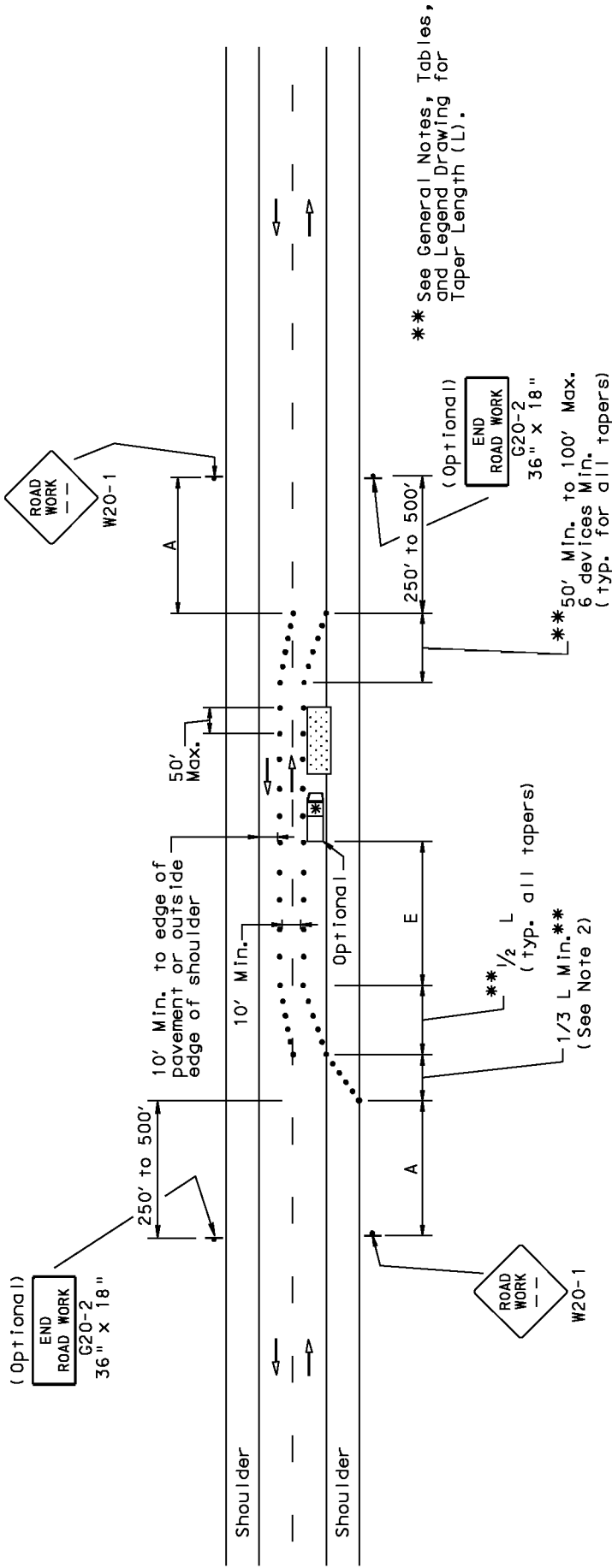

All Highways (except freeway and expressway)		
MPH	D	E*
25	50	155
30	60	200
35	70	250
40	80	305
45	90	360
50	100	425
55	110	495

* Distances may be increased for downgrades or other conditions that affect stopping sight distance.

Distance plaques on Advance Warning signs shall be the same series type.
 Example: either all XXX ft. or all "AHEAD"
 CONDITION 1: All Highways (except Freeways and Expressways)
 A = 500 ft., W20-1 sign distance plaque to read 500 ft. or "AHEAD"
 CONDITION 2: For Urban Streets
 A = 200 ft. and sign distance plaque to read "AHEAD"

NOTES

1. Where traffic is required to use a shoulder, it must be a paved shoulder that is in good condition both during the period it is being used by traffic and also after the work is completed.
2. When paved shoulders having a width of 8 ft or more are closed, channelizing devices should be used to close the shoulder in advance of the shifting taper.
3. Parking shall be prohibited where required. Coordinate with local authorities.

PUBLICATION 213
 SHORT-TERM STATIONARY OPERATION
 TWO-LANE, TWO-WAY ROADWAY - WORK AREA IN THE CENTER OF THE ROADWAY

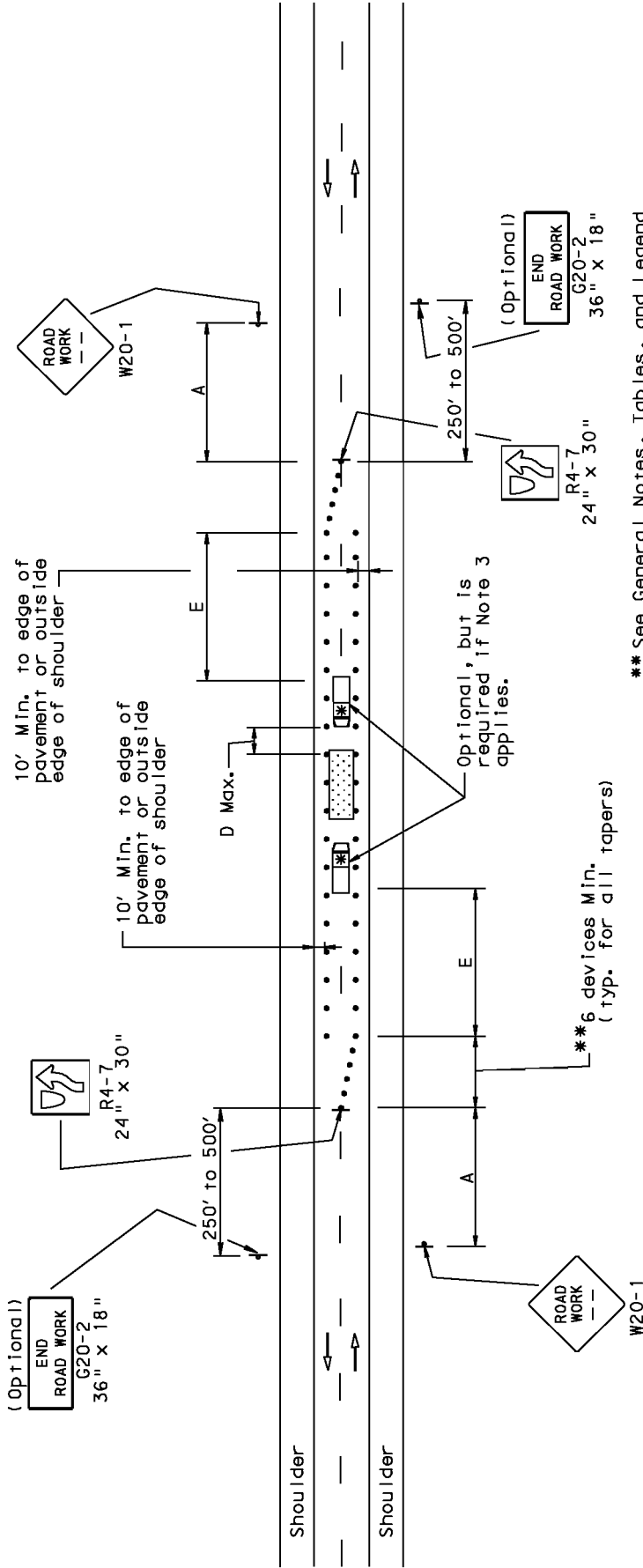

** See General Notes, Tables, and Legend Drawing for Taper Length (L).

** 6 devices Min. (typ. for all tapers)

Distance plaques on Advance Warning signs shall be the same series type.
 Example: either all XXX ft. or all "AHEAD"
 CONDITION 1: All Highways (except Freeways and Expressways)
 A = 500 ft., W20-1 sign distance plaque to read 500 ft. or "AHEAD"
 CONDITION 2: For Urban Streets
 A = 200 ft. and sign distance plaque to read "AHEAD"

NOTES

1. Where traffic is required to use a shoulder, it must be a paved shoulder that is in good condition both during the period it is being used by traffic and also after the work is completed.
2. The lanes on either side of the center work space should have a minimum width of 10 ft as measured from the near edge of the channelizing devices to the edge of pavement or the outside edge of paved shoulder.
3. For operations 15 minutes or less, channelizing devices may be eliminated if a vehicle with an activated flashing or revolving yellow light is present in advance of the work area and two, 10 ft minimum width lanes can be maintained past the work area.
4. Parking shall be prohibited where required. Coordinate with local authorities.

All Highways (except freeway and expressway)		
MPH	D	E*
25	50	155
30	60	200
35	70	250
40	80	305
45	90	360
50	100	425
55	110	495

* Distances may be increased for downgrades or other conditions that affect stopping sight distance.

PATA
 9d S

PUBLICATION 213
LONG-TERM STATIONARY OPERATION
TWO-LANE, TWO-WAY ROADWAY - WORK AREA IN THE CENTER OF THE ROADWAY

**See General Notes, Tables, and Legend
Drawing for Taper Length (L).

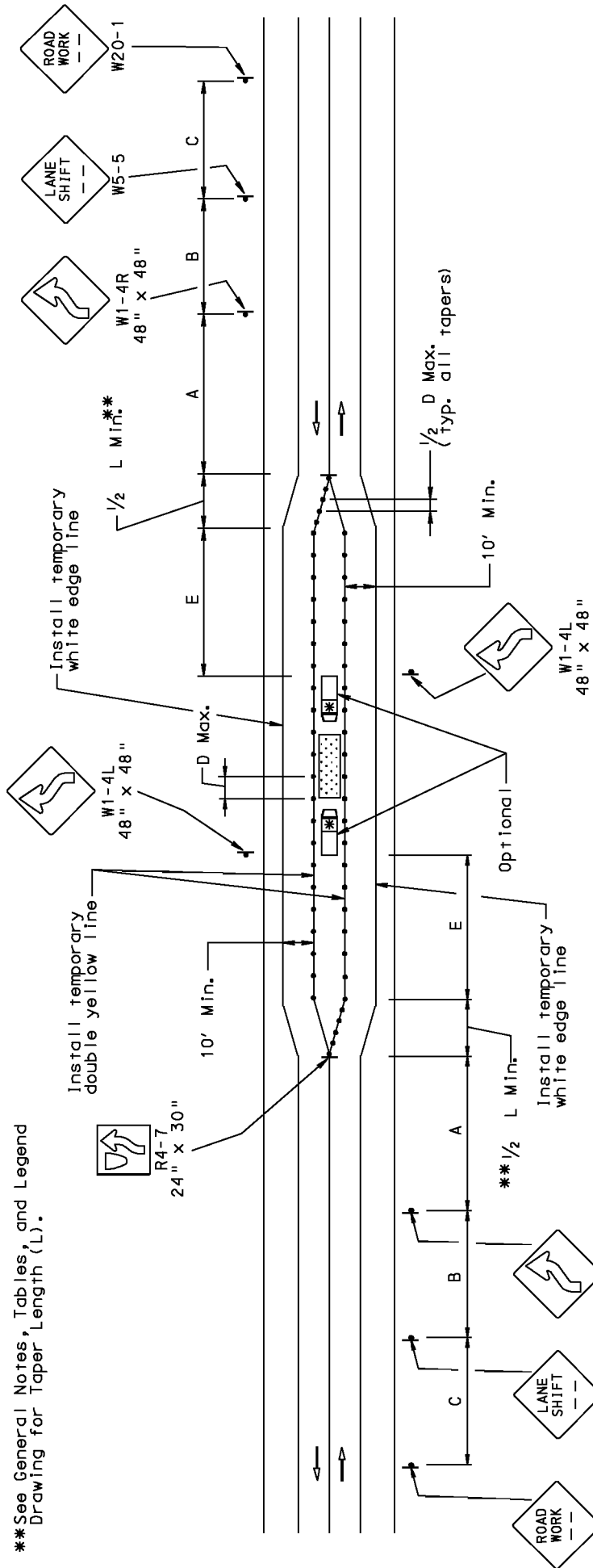

Distance plaques on Advance Warning signs shall be the same series type.

Example: either all XXX ft. or all "AHEAD"

CONDITION 1: All Highways (except Freeways and Expressways)
A = 500 ft.
B = 500 ft., W5-5 sign distance plaque to read 1000 ft.
C = 500 ft., W20-1 sign distance plaque to read 1500 ft.

CONDITION 2: For Urban Streets
A, B and C = 200 ft. and sign distance plaque to read "AHEAD"

NOTES

1. Where traffic is required to use a shoulder, it must be a paved shoulder that is in good condition both during the period it is being used by traffic and also after the work is completed.
2. Travel lanes shall have a minimum width of 10 feet as measured from the near edge of the channelizing devices to the edge of pavement or the outside edge of paved shoulder.
3. Parking shall be prohibited where required. Coordinate with local authorities.
4. If work area is in a passing zone, apply a temporary double yellow line over the passing zone markings on the approaches to the work area, install R4-1 DO NOT PASS signs, 24"x30", and cover any conflicting signs indicating a passing zone.
5. Remove conflicting pavement markings.

All Highways (except freeway and expressway)	E*	
	D	E*
MPH	ft	ft
25	50	155
30	60	200
35	70	250
40	80	305
45	90	360
50	100	425
55	110	495

* Distances may be increased for downgrades or other conditions that affect stopping sight distance.

PATA
9a L1

PUBLICATION 213
LONG-TERM STATIONARY OPERATION
TWO-LANE, TWO-WAY ROADWAY - WORK AREA IN THE LEFT OR RIGHT SIDE OF THE ROADWAY

**See General Notes, Tables, and Legend Drawing for Taper Length (L).

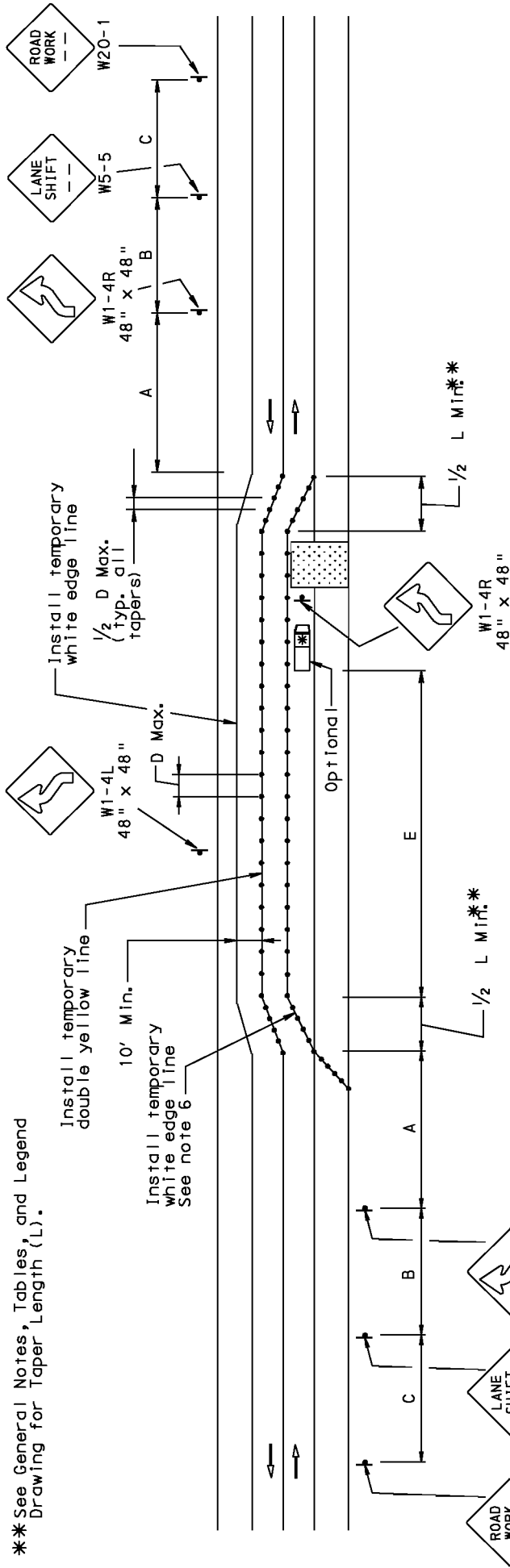

Distance plaques on Advance Warning signs shall be the same series type.
 Example: either all XXX ft. or all "AHEAD"
 CONDITION 1: All Highways (except Freeways and Expressways)
 A = 500 ft.
 B = 500 ft., W5-5 sign distance plaque to read 1000 ft.
 C = 500 ft., W20-1 sign distance plaque to read 1500 ft.
 CONDITION 2: For Urban Streets
 A, B and C = 200 ft. and sign distance plaque to read "AHEAD"

NOTES:

1. Where traffic is required to use a shoulder, it must be a paved shoulder that is in good condition both during the period it is being used by traffic and also after the work is completed.
2. Travel lanes shall have a minimum width of 10 feet as measured from the near edge of the channelizing devices to the edge of pavement or the outside edge of paved shoulder.
3. Parking shall be prohibited where required. Coordinate with local authorities.
4. If work area is in a passing zone, apply a temporary double yellow line over the passing zone markings on the approaches to the work area. Install R4-1 DO NOT PASS signs, 24"x30", and cover any conflicting signs indicating a passing zone.
5. Remove conflicting pavement markings.
6. Where channelizing devices are used instead of pavement markings for edge lines, the spacing shall be 1/2 D Max.
7. When paved shoulders having a width of 8 ft or more are closed, channelizing devices should be used to close the shoulder in advance of the shifting taper.

All Highways (except freeway and expressway)	E*	
	D	E*
MPH	ft	ft
25	50	155
30	60	200
35	70	250
40	80	305
45	90	360
50	100	425
55	110	495

* Distances may be increased for downgrades or other conditions that affect stopping sight distance.

PATA
9d L2

PUBLICATION 213
SHORT-TERM STATIONARY OPERATION
TWO-LANE, TWO-WAY ROADWAY - WORK AREA IN THE CENTER OF AN INTERSECTION

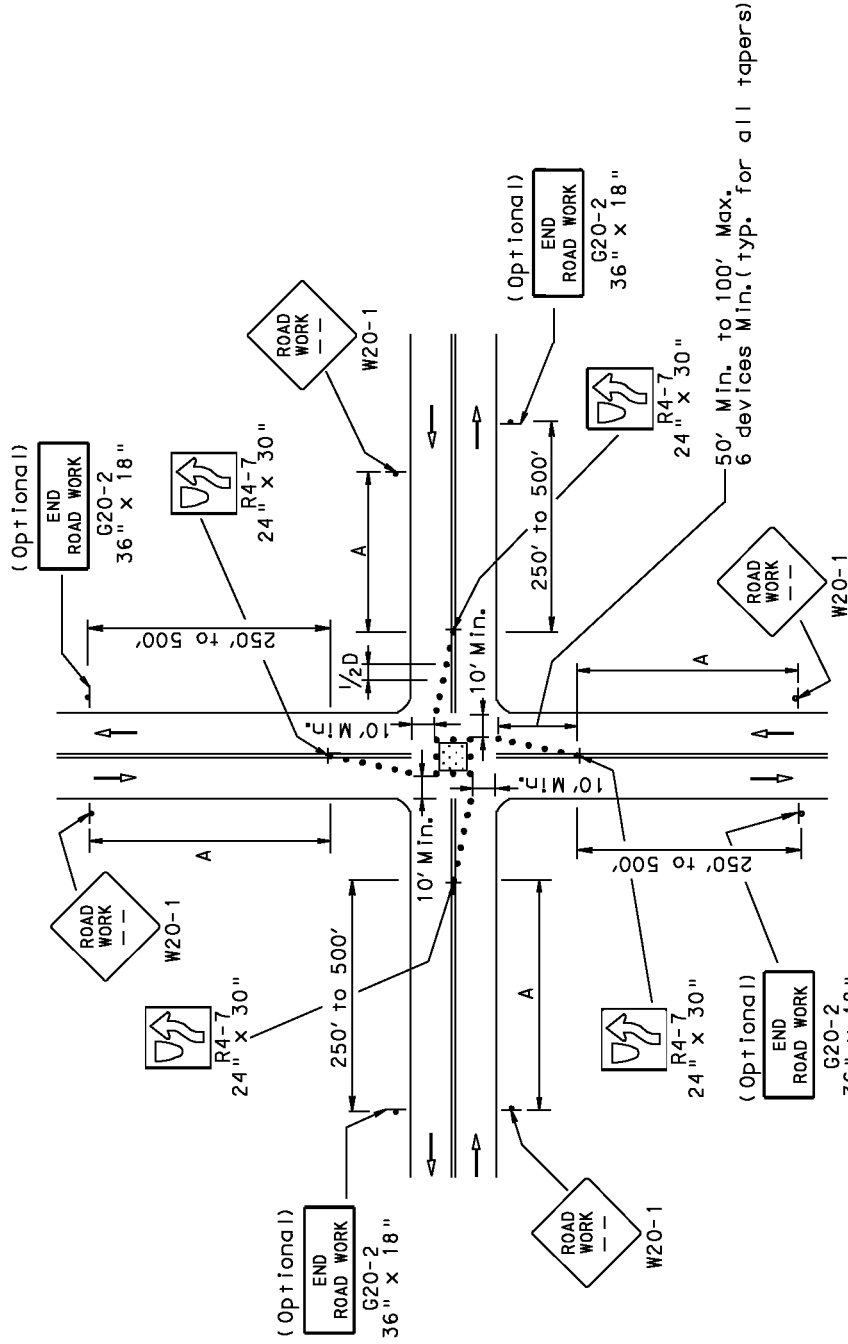

Distance plaques on Advance Warning signs shall be the same series type.
Example: either all XXX ft. or all "AHEAD"

CONDITION 1: All Highways (except Freeways and Expressways)
A = 500 ft., W20-1 sign distance plaque to read 500 ft. or "AHEAD"
D = 2 times the normal speed limit

CONDITION 2: For Urban Streets
A = 200 ft. and sign distance plaque to read "AHEAD"
D = 2 times the normal speed limit

NOTES

1. For operations 15 minutes or less in duration, channelizing devices may be eliminated if a vehicle with an activated flashing or revolving yellow light is present in the work area.
2. All lanes should be a minimum of 10 ft in width as measured to the near face of the channelizing device.
3. When vehicular traffic does not include longer and wider heavy commercial vehicles, a minimum lane width of 9 ft may be used.
4. Left turns may be prohibited as required by geometric conditions.

PUBLICATION 213
SHORT-TERM STATIONARY OPERATION
SURVEYING ALONG CENTERLINE OF ROAD WITH LOW TRAFFIC VOLUMES

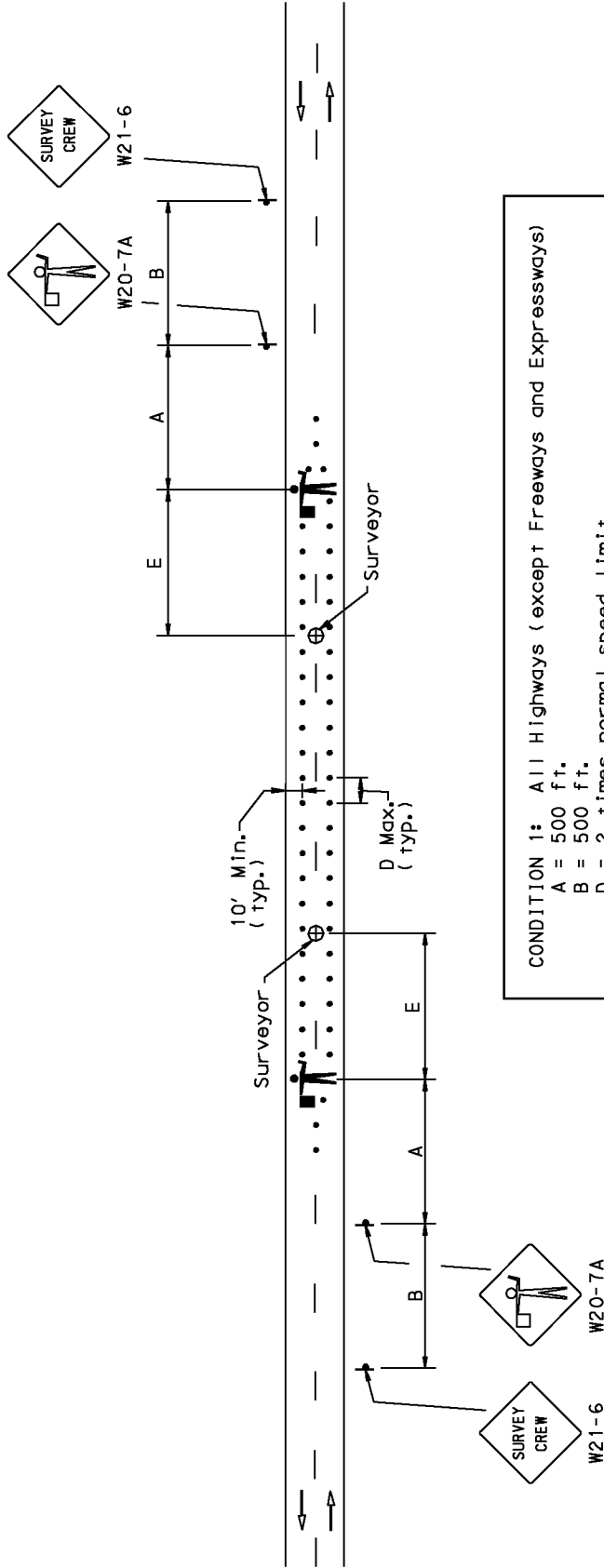

CONDITION 1: All Highways (except Freeways and Expressways)
 A = 500 ft.
 B = 500 ft.
 D = 2 times normal speed limit

CONDITION 2: For Urban Streets
 A and B = 200 ft.
 D = 2 times normal speed limit

NOTES

1. Cones should be placed 6 inches to 12 inches on either side of the centerline.
2. As shown on this figure, a flagger should be used to warn workers who cannot watch road users.
3. This figure should be used only where the ADT is not greater than approximately 1500, or the average 5-minute traffic volume during the period of work is 12 vehicles or less. For surveying the centerline of a high-volume road, one lane shall be closed as shown in PATA 10a.
4. Road Work Ahead Signs (W20-1) may be used in place of the Survey Crew Signs (W21-6).
5. If the work is along the shoulder, the flagger and the W20-7A sign may be omitted.
6. A Be Prepared To Stop Sign (W3-4) may be added to the sign series. When used, it should be located before the W20-7A Sign.
7. Channelizing devices may be omitted for cross-section survey.
8. Spacing of channelizing devices should not exceed a distance in feet equal to 1/2 D when used for the taper channelization and a distance in feet equal to D when used for tangent channelization.

All Highways (except freeway and expressway)		
MPH	D ft	E* ft
25	50	155
30	60	200
35	70	250

*Distances may be increased for downgrades or other conditions that affect stopping sight distance.

PATA
9C

PUBLICATION 213
 SHORT-TERM STATIONARY OPERATION
 TWO-LANE, TWO-WAY ROADWAY - FLAGGING

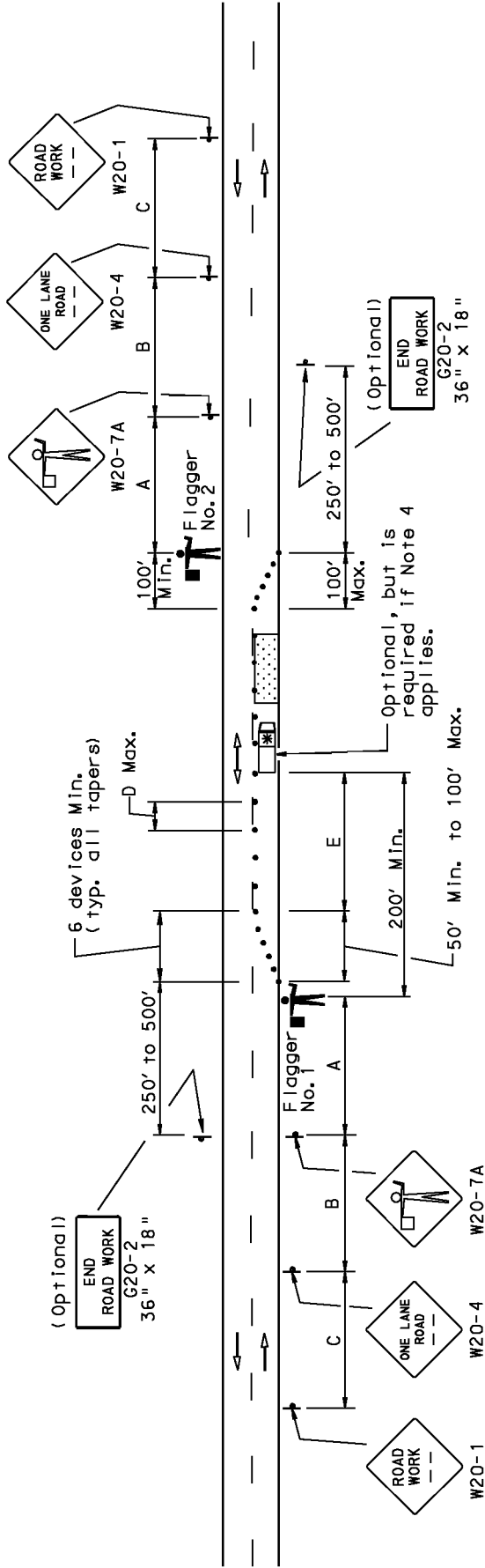

Distance plaques on Advance Warning signs shall be the same series type.
 Examples: either all XXX ft. or all "AHEAD"

CONDITION 1: All Highways (except Freeways and Expressways)
 A = 500 ft.
 B = 500 ft., W20-4 sign distance plaque to read 1000 ft. or "AHEAD"
 C = 500 ft., W20-1 sign distance plaque to read 1500 ft. or "AHEAD"

CONDITION 2: For Urban Streets
 A, B and C = 200 ft. and sign distance plaque to read "AHEAD"

All Highways (except freeway and expressway)		
MPH	D ft	E* ft
25	50	155
30	60	200
35	70	250
40	80	305
45	90	360
50	100	425
55	110	495

NOTES

- All flaggers must be in communication with each other.
- Each flagger should be clearly visible to traffic for a minimum distance of E.
- At night, flagger stations shall be illuminated, except in emergencies. See General Notes, sheet 3, note 26.
- For operations of 15 minutes or less:
 - The W20-1 and W20-4 Signs are not required.
 - All channelizing devices may be eliminated if a vehicle with an activated flashing or revolving yellow light is present in advance of the work space.
 - The W20-7A Sign may be eliminated if the flagger is clearly visible to traffic for a minimum distance of E.
- The buffer space should be extended so that the two-way traffic taper is placed before a horizontal (or crest vertical) curve to provide adequate sight distance for the flagger and a queue of stopped vehicles.
- When a highway-rail grade crossing exists within the work zone, or it is anticipated that queues resulting from the lane closure might extend through a highway-rail grade crossing, provisions shall be made to eliminate conflicts, which may require placing a flagger at the crossing. Coordination with the railroad is essential.

*Distances may be increased for downgrades or other conditions that affect stopping sight distance.

NOTES

1. All flaggers must be in communication with each other.
2. Each flagger should be clearly visible to traffic for a minimum distance of E.
3. At night, flagger stations shall be illuminated, except in emergencies. See General Notes, sheet 3, note 26.
4. For operations of 15 minutes or less:
 - a. The W20-1 sign is not required.
 - b. All channelizing devices may be eliminated if a vehicle with an activated flashing or revolving yellow light is present in advance of the work space.
 - c. The W20-7A sign may be eliminated if the flagger is clearly visible to traffic for a minimum distance of E.
5. The buffer space should be extended so that the two-way traffic taper is placed before a horizontal (or crest vertical) curve to provide adequate sight distance for the flagger and a queue of stopped vehicles.
6. When a highway-rail grade crossing exists within the work zone, or it is anticipated that queues resulting from the lane closure might extend through a highway-rail grade crossing, provisions shall be made to eliminate conflicts, which may require placing a flagger at the crossing. Coordination with the railroad is essential.
7. At signalized intersections, contact local municipality for authorization to place signal into flash mode.

All Highways (except freeway and expressway)		E*
MPH	D	ft
25	50	155
30	60	200
35	70	250
40	80	305
45	90	360
50	100	425
55	110	495

*Distances may be increased for downgrades or other conditions that affect stopping sight distance.

Distance plaques on Advance Warning signs shall be the same series type.
Example: either all XXX ft. or all "AHEAD"

CONDITION 1: All Highways (except Freeways and Expressways)
A = 500 ft.
B = 500 ft., W20-4 sign distance plaque to read 1000 ft. or "AHEAD"
C = 500 ft., W20-1 sign distance plaque to read 1500 ft. or "AHEAD"

CONDITION 2: For Urban Streets
A, B and C = 200 ft. and sign distance plaque to read "AHEAD"

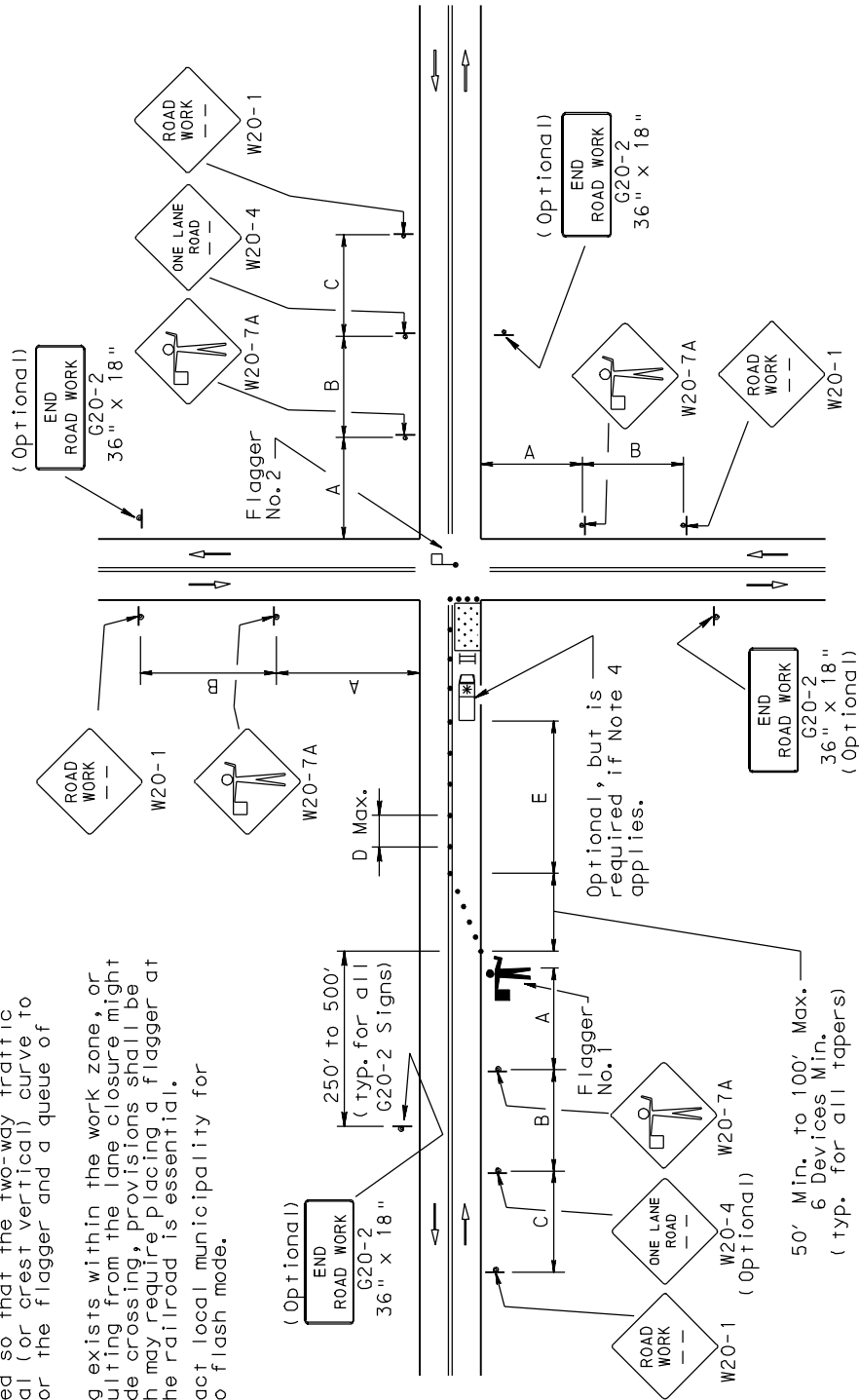

PUBLICATION 213
 SHORT-TERM STATIONARY OPERATION
 TWO-LANE, TWO-WAY ROADWAY - SINGLE FLAGGER

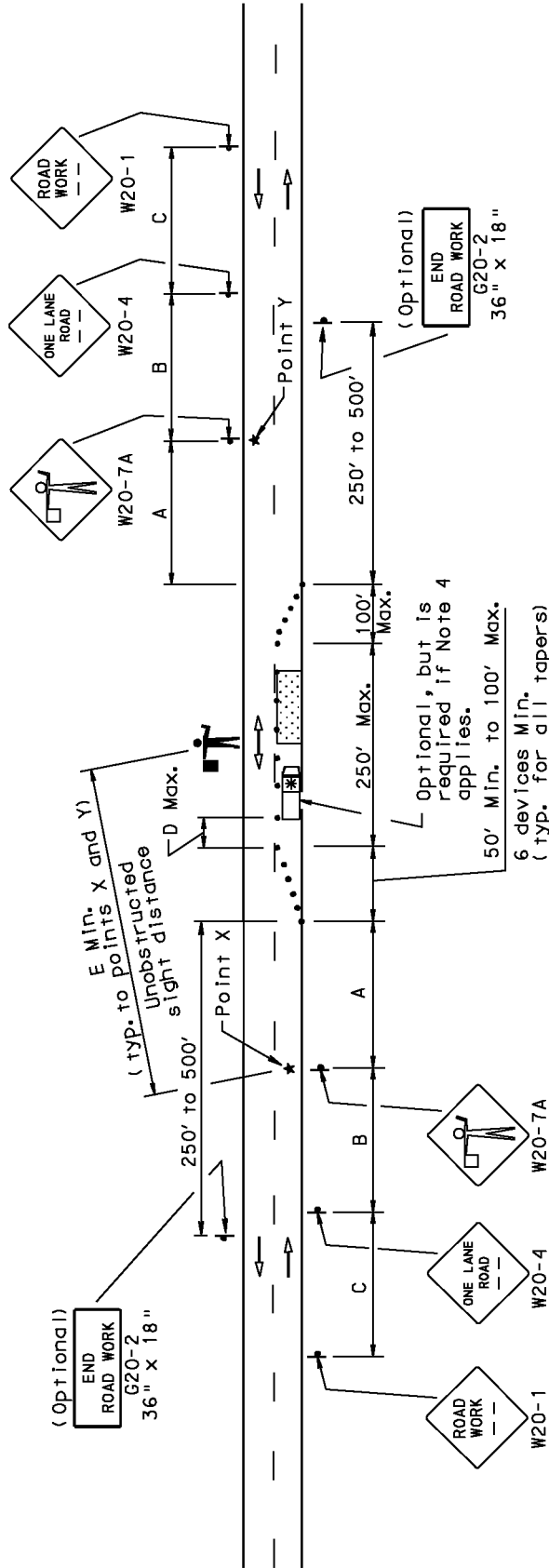

Distance plaques on Advance Warning signs shall be the same series type.

Example: either all XXX ft. or all "AHEAD"

CONDITION 1: All Highways (except Freeways and Expressways)

- A = 500 ft.
- B = 500 ft., W20-4 sign distance plaque to read 1000 ft. or "AHEAD"
- C = 500 ft., W20-1 sign distance plaque to read 1500 ft. or "AHEAD"

CONDITION 2: For Urban Streets

- A, B and C = 200 ft. and sign distance plaque to read "AHEAD"

All Highways (except freeway and expressway)	E *	
	D	f t
MPH	f t	f t
25	50	155
30	60	200
35	70	250
40	80	305
45	90	360
50	100	425
55	110	495

*Distances may be increased for downgrades or other conditions that affect stopping sight distance.

NOTES

1. This figure applies when all of the following conditions are satisfied:
 - a. Sight distance between the flagger and any vehicle between Points X and Y will be unobstructed.
 - b. The length of the one-lane section (not including any taper) is not greater than approximately 250 ft.
 - c. The ADT is not greater than approximately 1500, or the average 5-minute traffic volume during the period of work is 12 vehicles or less.
2. Flagger should be clearly visible to traffic for a minimum distance of E.
3. At night, flagger station shall be illuminated, except in emergencies. See General Notes, sheet 3, note 26.
4. For operations of 15 minutes or less:
 - a. The W20-1 and W20-4 Signs are not required.
 - b. All channelizing devices may be eliminated if a vehicle with an activated flashing or revolving yellow light is present in advance of the work space.
 - c. The W20-7A Sign may be eliminated if the flagger is clearly visible to traffic for a minimum distance of E.
5. When a highway-rail grade crossing exists within the work zone, or it is anticipated that queues resulting from the lane closure might extend through a highway-rail grade crossing, provisions shall be made to eliminate conflicts, which may require placing a flagger at the crossing. Coordination with the railroad is essential.

PUBLICATION 213
SHORT-TERM STATIONARY OPERATION
TWO-LANE, TWO-WAY ROADWAY - STOP SIGN-CONTROLLED LANE CLOSURE

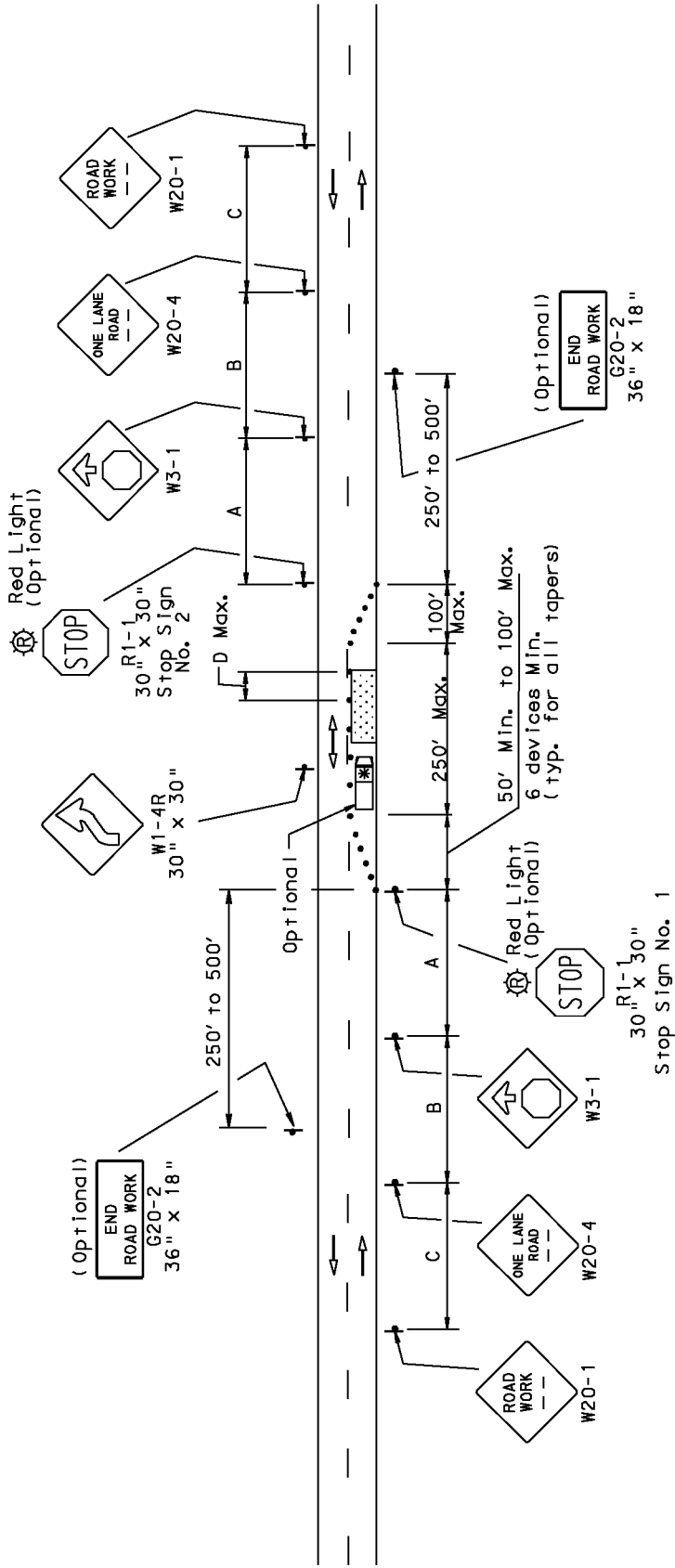

Distance plaques on Advance Warning signs shall be the same series type.
Example: either all XXX ft. or all "AHEAD"

CONDITION 1: All Highways (except Freeways and Expressways)
 A = 500 ft.
 B = 500 ft., W20-4 sign distance plaque to read 1000 ft. or "AHEAD"
 C = 500 ft., W20-1 sign distance plaque to read 1500 ft. or "AHEAD"
 D = 2 times the normal speed limit

CONDITION 2: For Urban Streets
 A, B and C = 200 ft. and sign distance plaque to read "AHEAD"
 D = 2 times the normal speed limit

NOTES

1. This figure applies when all of the following conditions are satisfied:
 - a. Sight distance between the Stop Signs will be unobstructed.
 - b. The length of the one-lane section (not including any taper) is not greater than approximately 250 ft.
 - c. The ADT is not greater than approximately 1500, or the average 5-minute traffic volume during the period of work is 12 vehicles or less.

PATA
10d

PUBLICATION 213
SHORT-TERM STATIONARY OPERATION
TWO-LANE, TWO-WAY ROADWAY - SELF-REGULATING LANE CLOSURE

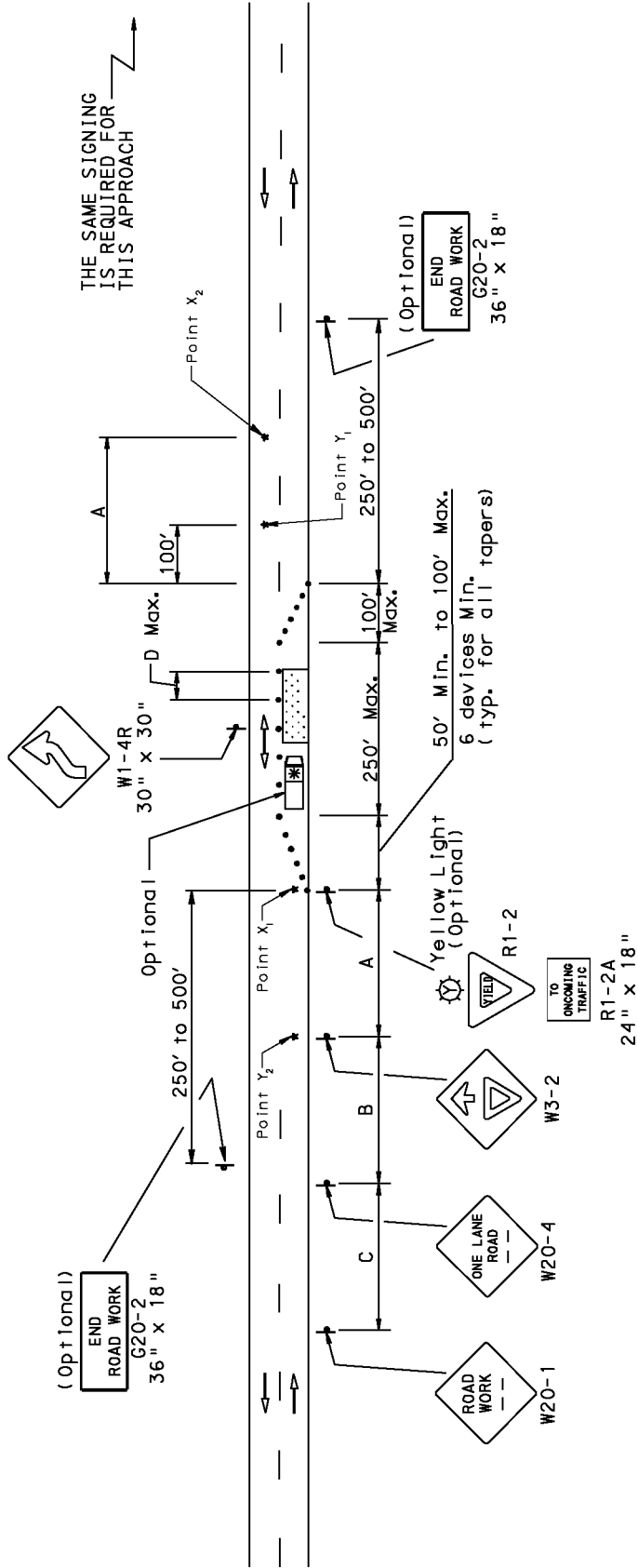

Distance plaques on Advance Warning signs shall be the same series type.

Example: either all XXX ft. or all "AHEAD"

CONDITION 1: All Highways (except Freeways and Expressways)

- A = 500 ft.
- B = 500 ft., W20-4 sign distance plaque to read 1000 ft. or "AHEAD"
- C = 500 ft., W20-1 sign distance plaque to read 1500 ft. or "AHEAD"
- D = 2 times the normal speed limit

CONDITION 2: For Urban Streets

- A, B and C = 200 ft. and sign distance plaque to read "AHEAD"
- D = 2 times the normal speed limit

NOTES

1. This figure applies when all of the following conditions are satisfied:
 - a. Sight distance between X_1 and X_2 , and between Y_1 and Y_2 , will be unobstructed.
 - b. The length of the one-lane section (not including any taper) is not greater than approximately 250 ft.
 - c. The ADT is not greater than approximately 750, or the average 5-minute traffic volume during the period of work is 6 vehicles or less.
2. For operations 60 minutes or less in duration, a taper is not required if a vehicle with an activated flashing or revolving yellow light is located in the closed lane as shown. If a taper is not used, Point X_1 shall be approximately 150 ft from the rear of the vehicle with an activated flashing or revolving yellow light.

PUBLICATION 213
 SHORT-TERM STATIONARY OPERATION - TWO-LANE, TWO-WAY ROADWAY
 RED/YELLOW AFAD - FLAGGER AT ONE END, AFAD AT THE OTHER END

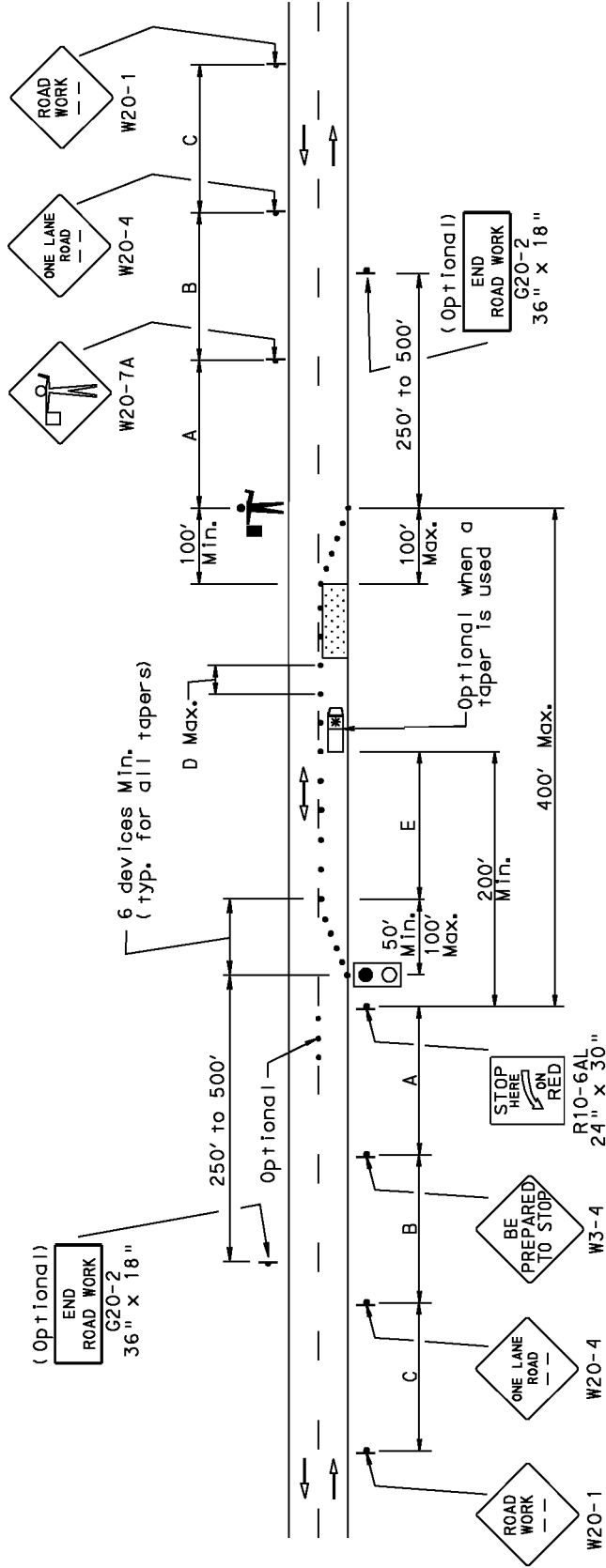

MPH	All Highways (except freeway and expressway)	
	D	E*
25	50	155
30	60	200
35	70	250
40	80	305
45	90	360
50	100	425
55	110	495

* Distances may be increased for downgrades or other conditions that affect stopping sight distance.

Distance plaques on Advance Warning signs shall be the same series type.
 Example: either all XXX ft. or all "AHEAD"
 CONDITION 1: All Highways (except Freeways and Expressways)
 A = 500 ft.
 B = 500 ft., W20-4 sign distance plaque to read 1000 ft. or "AHEAD"
 C = 500 ft., W20-1 sign distance plaque to read 1500 ft. or "AHEAD"
 CONDITION 2: For Urban Streets
 A, B and C = 200 ft. and sign distance plaque to read "AHEAD"

PUBLICATION 213
 SHORT-TERM STATIONARY OPERATION - TWO-LANE, TWO-WAY ROADWAY
 RED/YELLOW AFAD - FLAGGER AT ONE END, AFAD AT THE OTHER END

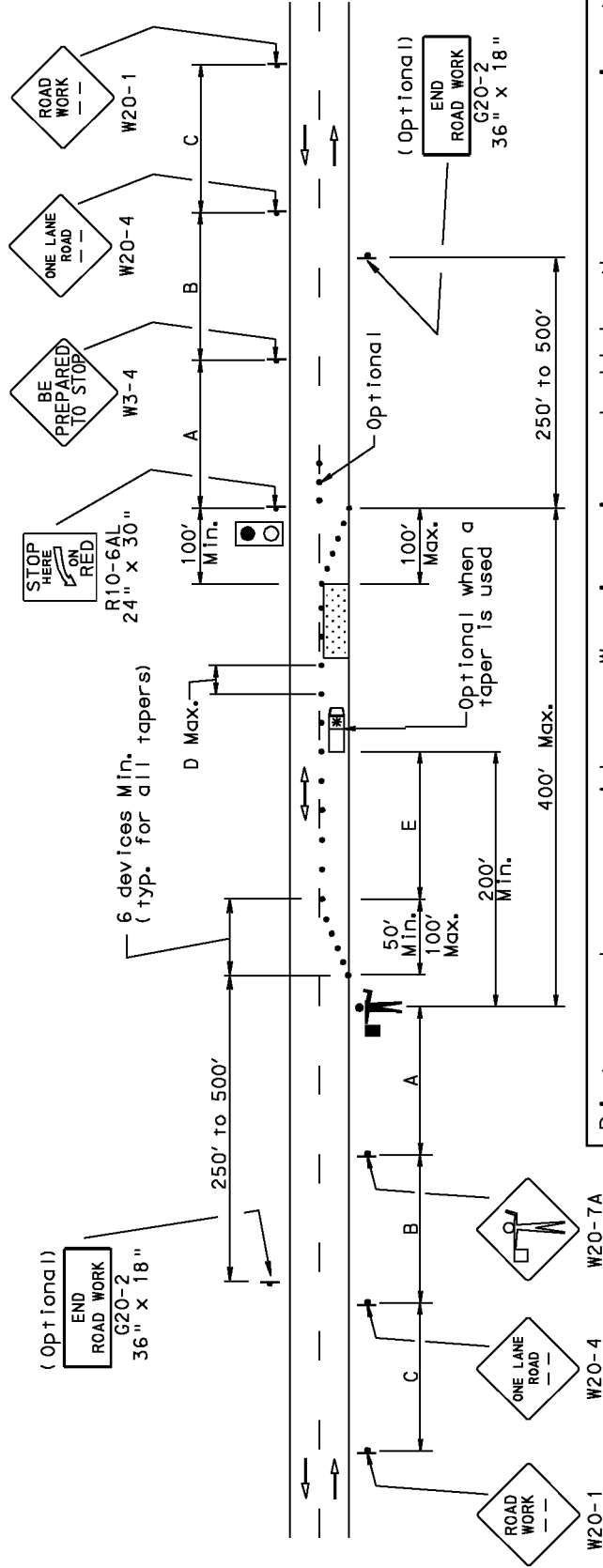

Distance plaques on Advance Warning signs shall be the same series type.
 Example: either all XXX ft. or all "AHEAD"
 CONDITION 1: All Highways (except Freeways and Expressways)
 A = 500 ft.
 B = 500 ft., W20-4 sign distance plaque to read 1000 ft. or "AHEAD"
 C = 500 ft., W20-1 sign distance plaque to read 1500 ft. or "AHEAD"
 CONDITION 2: For Urban Streets
 A, B and C = 200 ft. and sign distance plaque to read "AHEAD"

NOTES

1. The flagger and Automated Flagger Assistance Device (AFAD) should be clearly visible to traffic for a minimum distance of E.
2. At night, the flagger stations shall be illuminated, except in emergencies.
3. See General Notes, sheet 3, note 26.
4. The buffer space should be extended so that the two-way traffic taper is placed before a horizontal (or crest vertical) curve to provide adequate sight distance for the flagger and a queue of stopped vehicles.
5. When a highway-rail grade crossing exists within the work zone, or it is anticipated that queues resulting from the lane closure might extend through a highway-rail grade crossing, provisions shall be made to eliminate conflicts, which may require placing a flagger at the crossing. Coordination with the railroad is essential.

All Highways (except freeway and expressway)		
MPH	D	E*
	ft	ft
25	50	155
30	60	200
35	70	250
40	80	305
45	90	360
50	100	425
55	110	495

* Distances may be increased for downgrades or other conditions that affect stopping sight distance.

PUBLICATION 213
 SHORT-TERM STATIONARY OPERATION - TWO-LANE, TWO-WAY ROADWAY
 RED/YELLOW AFAD - AFAD WITH FLAGGER AT BOTH ENDS

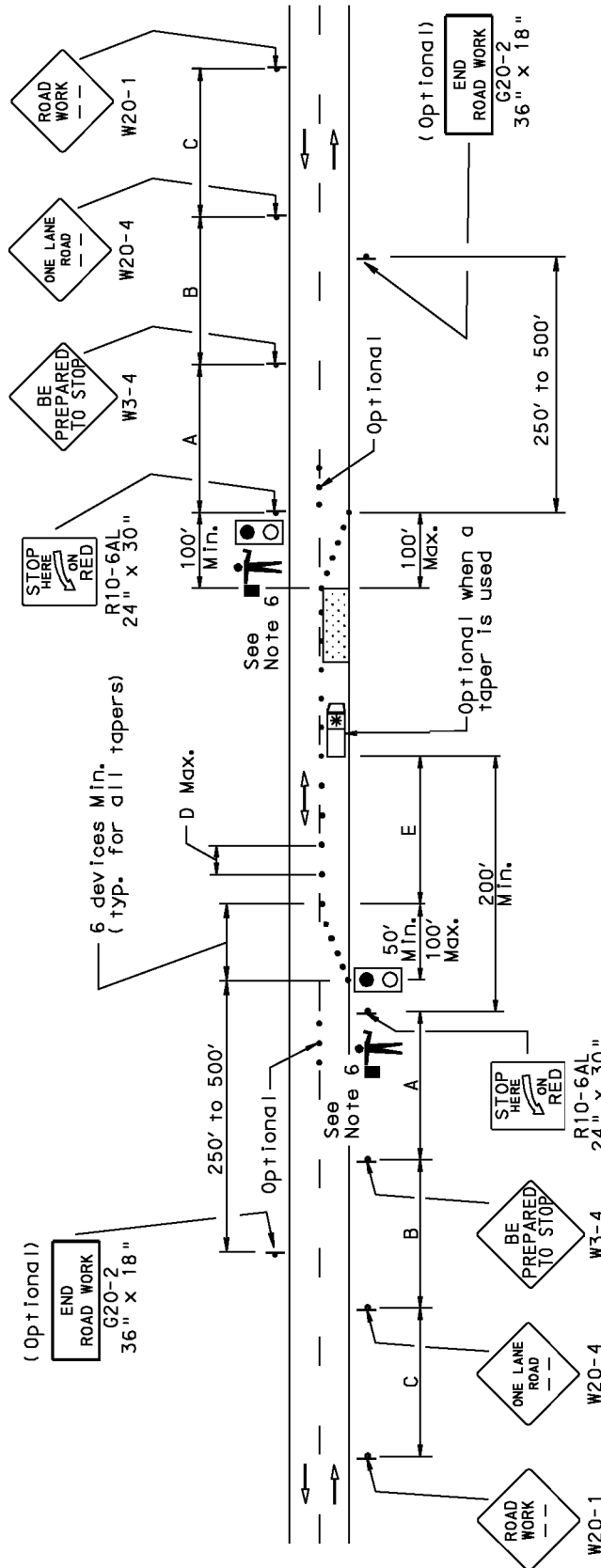

Distance plaques on Advance Warning signs shall be the same series type.
 Example: either all XXX ft. or all "AHEAD"

- CONDITION 1: All Highways (except Freeways and Expressways)
 A = 500 ft.
 B = 500 ft., W20-4 sign distance plaque to read 1000 ft. or "AHEAD"
 C = 500 ft., W20-1 sign distance plaque to read 1500 ft. or "AHEAD"

- CONDITION 2: For Urban Streets
 A, B and C = 200 ft. and sign distance plaque to read "AHEAD"

NOTES

1. All flaggers must be in communication with each other.
2. Each Automated Flagger Assistance Device (AFAD) should be clearly visible to traffic for a minimum distance of E.
3. At night, the flagger stations shall be illuminated, except in emergencies. See General Notes, sheet 3, note 26.
4. The buffer space should be extended so that the two-way traffic taper is placed before a horizontal (or crest vertical) curve to provide adequate sight distance for the flagger and a queue of stopped vehicles.
5. When a highway-rail grade crossing exists within the work zone, or it is anticipated that queues resulting from the lane closure might extend through a highway-rail grade crossing, provisions shall be made to eliminate conflicts, which may require placing a flagger at the crossing. Coordination with the railroad is essential.
6. While operating the AFAD a flagger should position themselves beside the AFAD away from traffic so not to block an escape route.

All Highways (except freeway and expressway)	E*	
	D	E*
MPH	ft	ft
25	50	155
30	60	200
35	70	250
40	80	305
45	90	360
50	100	425
55	110	495

* Distances may be increased for downgrades or other conditions that affect stopping sight distance.

PATA
 10AFAD-2

PUBLICATION 213
 SHORT-TERM STATIONARY OPERATION - TWO-LANE, TWO-WAY ROADWAY
 RED/YELLOW AFAD - AFAD AT BOTH ENDS, SINGLE FLAGGER CENTRALLY LOCATED

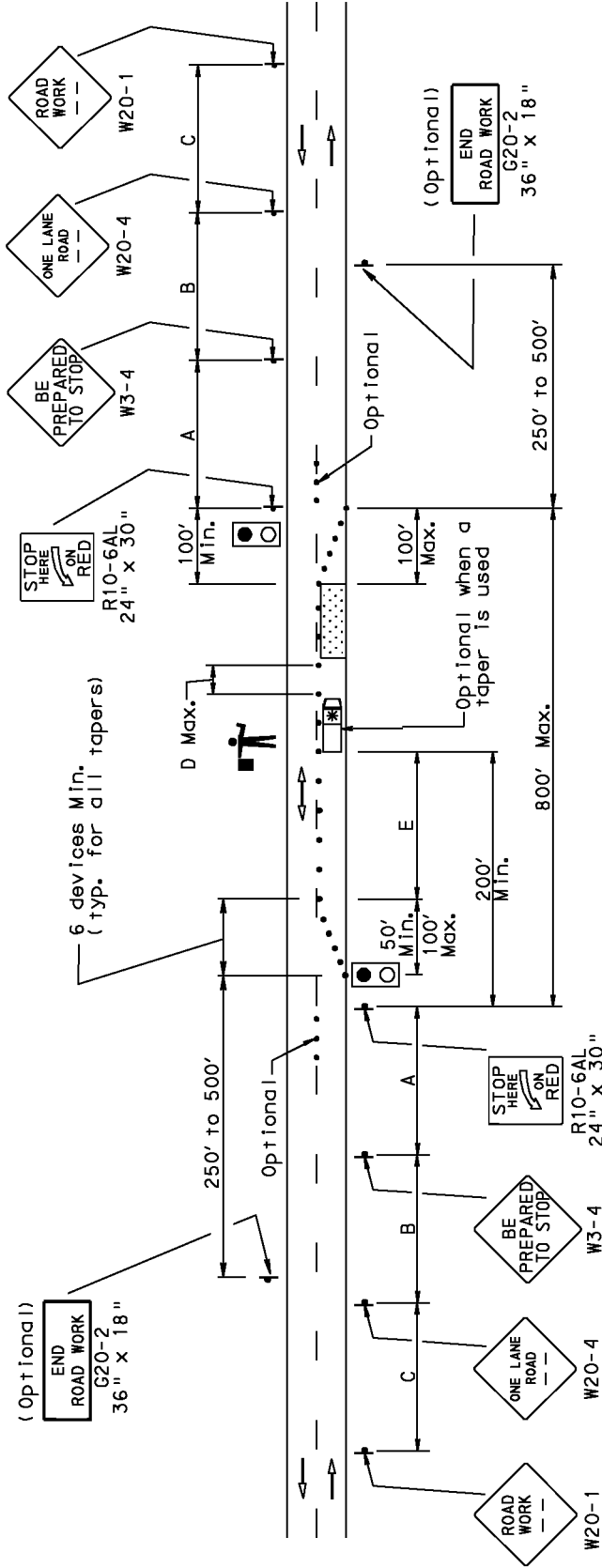

MPH	All Highways (except freeway and expressway)	
	D	E*
25	50	155
30	60	200
35	70	250
40	80	305
45	90	360
50	100	425
55	110	495

* Distances may be increased for downgrades or other conditions that affect stopping sight distance.

Distance plaques on Advance Warning signs shall be the same series type.

Example: either all XXX ft. or all "AHEAD"

CONDITION 1: All Highways (except Freeways and Expressways)

- A = 500 ft.
- B = 500 ft., W20-4 sign distance plaque to read 1000 ft. or "AHEAD"
- C = 500 ft., W20-1 sign distance plaque to read 1500 ft. or "AHEAD"

CONDITION 2: For Urban Streets

- A, B and C = 200 ft. and sign distance plaque to read "AHEAD"

NOTES

1. Each Automated Flagger Assistance Device (AFAD) should be clearly visible to traffic for a minimum distance of E.
2. At night, the flagger stations shall be illuminated, except in emergencies. See General Notes sheet 3, note 26.
3. The buffer space should be extended so that the two-way traffic taper is placed before a horizontal (or crest vertical) curve to provide adequate sight distance for the flagger and a queue of stopped vehicles.
4. When a highway-rail grade crossing exists within the work zone, or it is anticipated that queues resulting from the lane closure might extend through a highway-rail grade crossing, provisions shall be made to eliminate conflicts, which may require placing a flagger at the crossing. Coordination with the railroad is essential.

PUBLICATION 213
SHORT-TERM MOBILE OPERATION
TWO-LANE, TWO-WAY ROADWAY - FLAGGING

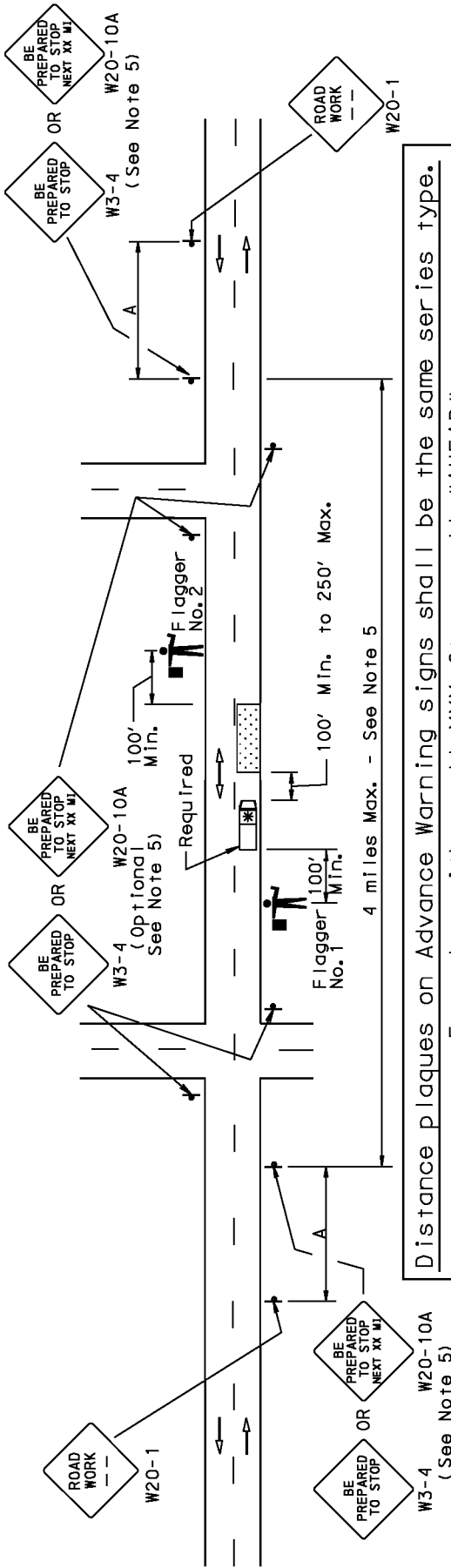

Distance plaques on Advance Warning signs shall be the same series type.
 Example: either all XXX ft. or all "AHEAD"
 CONDITION 1: All Highways (except Freeways and Expressways)
 A = 500 ft., W20-1 sign distance plaque to read 500 ft. or "AHEAD"
 CONDITION 2: For Urban Streets
 A = 200 ft. and sign distance plaque to read "AHEAD"

NOTES

- This figure applies for daylight operations that move intermittently or continuously at an average speed of less than 1 MPH (88 ft/min).
- All flaggers must be in communication with each other.
- Each flagger should be clearly visible to traffic for a minimum distance of E.
- The distance between a flagger and the W20-10A Sign shall be a minimum of A and a maximum of 2 miles. The flagger may be located in advance of the W20-10A Sign when flagging on an approach or within an intersection if all of the following conditions are met:
 - A vehicle with an activated flashing or revolving yellow light is present.
 - The operation will be 15 minutes or less in duration.
 - Flagger should be clearly visible to traffic for a minimum distance of E or there is a Stop Sign on the approach to the flagger.
 - The ADT entering the intersection is not greater than approximately 1500, or the average 5-minute traffic volume during the period of work is 12 vehicles or less.
- Interim W3-4 or W20-10A Signs will be required for any projects over 2 miles in length. However, if there will be no flaggers after the W3-4 or W20-10A Sign, the W3-4 or W20-10A Sign should be removed or turned away from traffic. The signing for intersection roads is optional but when signed, a W20-10A Sign shall be installed on the roadway where work is taking place on each side of the intersecting road as indicated.
- Additional flaggers may be required when working within or adjacent to an intersection.
- For surface treatment operations W21-5-1 Signs should be installed. The first sign in each direction should be placed where the W20-1 Signs are shown and the W20-1 Signs moved "A" distance upstream.
- A pilot vehicle is recommended for use with surface treatment operations on roads with ADTs of approximately 1000 or more.
- When a highway-rail grade crossing exists within the work zone, or it is anticipated that queues resulting from the lane closure might extend through a highway-rail grade crossing, provisions shall be made to eliminate conflicts, which may require placing a flagger at the crossing. Coordination with the railroad is essential.

All Highways ((except freeway and expressway)	E*	
	MPH	ft
	25	155
	30	200
	35	250
	40	305
	45	360
	50	425
	55	495

* Distances may be increased for downgrades or other conditions that affect stopping sight distance.

PATA
11a

PUBLICATION 213
 SHORT-TERM MOBILE OPERATION
 TWO-LANE, TWO-WAY ROADWAY - SINGLE FLAGGER

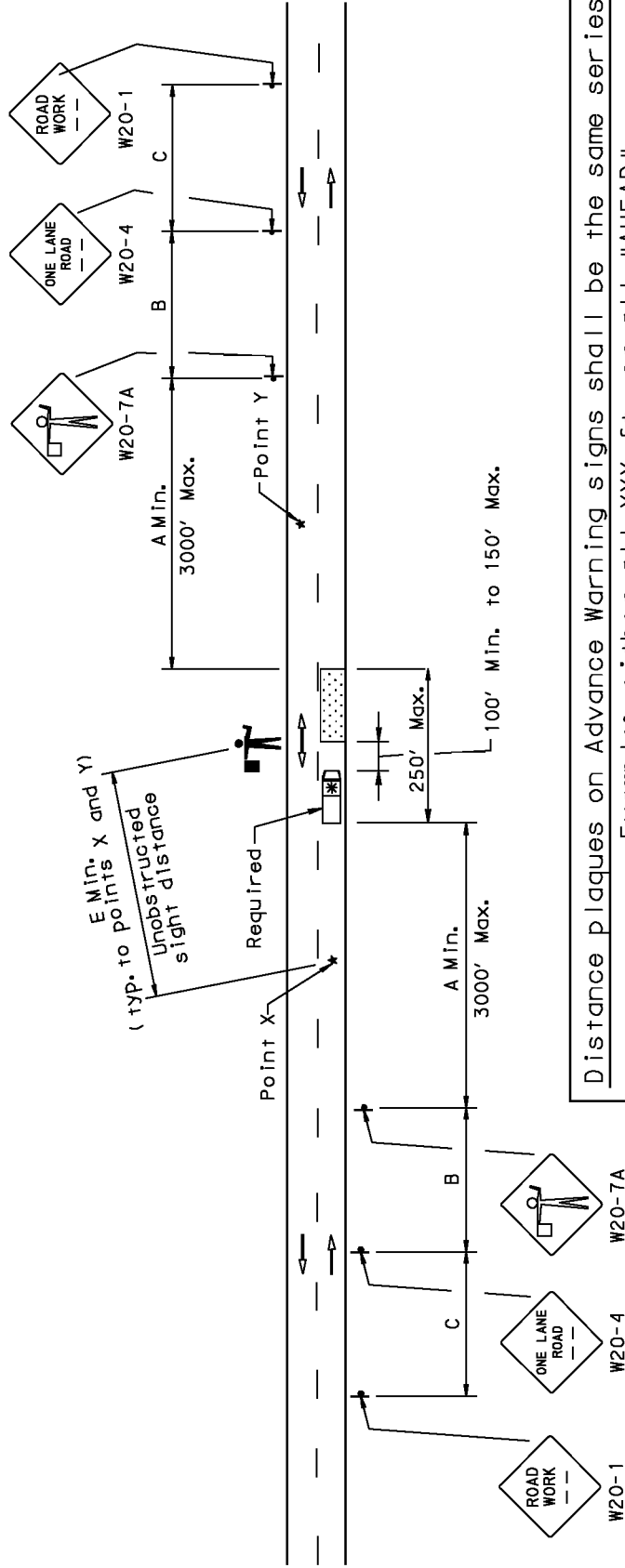

Distance plaques on Advance Warning signs shall be the same series type.
 Example: either all XXX ft. or all "AHEAD"

CONDITION 1: All Highways (except Freeways and Expressways)
 A = 500 ft.
 B = 500 ft., W20-4 sign distance plaque to read 1000 ft. or "AHEAD"
 C = 500 ft., W20-1 sign distance plaque to read 1500 ft. or "AHEAD"

CONDITION 2: For Urban Streets
 A, B and C = 200 ft. and sign distance plaque to read "AHEAD"

All Highways ((except freeway and expressway)	E *	
	MPH	ft
	25	155
	30	200
	35	250
	40	305
	45	360
	50	425
	55	495

*Distances may be increased for downgrades or other conditions that affect stopping sight distance.

NOTES

- This figure applies for daylight operations when all of the following conditions are satisfied:
 - The operation moves intermittently or continuously at an average speed of less than 1 MPH (88 ft/min).
 - Sight distance between the flagger and any vehicle between Points X and Y will be unobstructed.
 - The length of the one-lane section is not greater than approximately 250'.
 - The ADT is not greater than approximately 1500, or the average 5-minute traffic volume during the period of work is 12 vehicles or less.
- Flagger should be clearly visible to traffic for a minimum distance of E.
- For operations of 15 minutes or less
 - The W20-1 and W20-4 Signs are not required.
 - The W20-7A Sign may be eliminated if the flagger is clearly visible to traffic for a minimum distance of E.
- When a highway-rail grade crossing exists within the work zone, or it is anticipated that queues resulting from the lane closure might extend through a highway-rail grade crossing, provisions shall be made to eliminate conflicts, which may require placing a flagger at the crossing. Coordination with the railroad is essential.

PUBLICATION 213
 SHORT-TERM MOBILE OPERATION
 TWO-LANE, TWO-WAY ROADWAY - ROAD CLOSURE

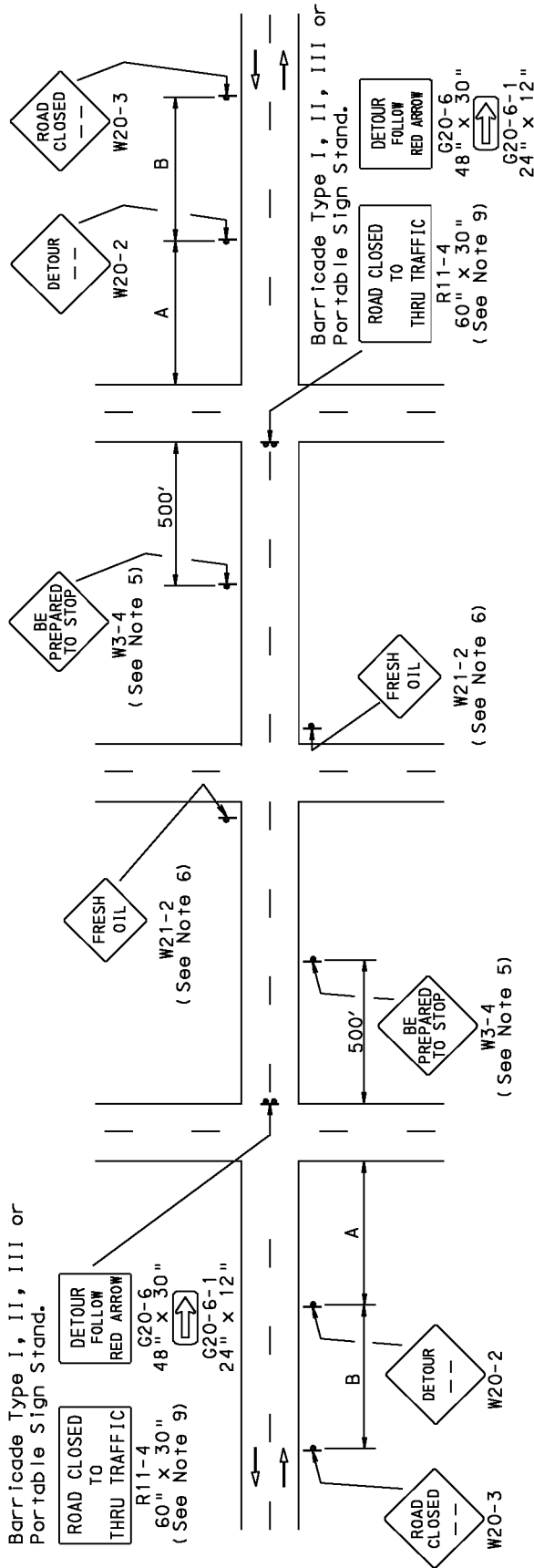

Distance plaques on Advance Warning signs shall be the same series type.

Example: either all XXX ft. or all "AHEAD"

CONDITION 1: All Highways (except Freeways and Expressways)

A = 500 ft., W20-2 sign distance plaque to read 500 ft. or "AHEAD"

B = 500 ft., W20-3 sign distance plaque to read 1000 ft. or "AHEAD"

CONDITION 2: For Urban Streets

A and B = 200 ft. and sign distance plaque to read "AHEAD"

NOTES

1. This figure applies for operations that move intermittently at an average speed of 1 MPH or less.
2. This setup is to be used during daylight hours only and only on roadways with ADT's of 1500 or less.
3. Hours of work should not interfere with rush hour traffic or school bus schedules and the work site must be capable of accommodating emergency vehicles with as little delay as possible.
4. Flaggers may be needed with the operations to control local traffic and at intersections. Flaggers must be in communication with each other.
5. The maximum distance between a flagger with the operation and a W3-4 Sign is 2 miles. Interim W3-4 Signs will be required for any project over 2 miles in length; however, if there will be no flaggers between the W3-4 Sign and the R11-4 Sign, the W3-4 Sign should be removed or turned away from traffic.
6. The signing of intersecting roads with W21-2 Signs is required when the ADT of the intersecting road is 200 or greater.
7. Roads used as alternate routes should be owned and maintained by the Commonwealth (Department projects only).
8. At locations where there are overlapping detours or several detours within the same area, street names may be added to the G20-6 and G20-6-1 Signs, or signs with different colored arrows may be used to designate the different detour routes. The design and application of signs displaying colored arrows shall comply with Publication 236M.
9. The R11-3A (60" x 30") "ROAD CLOSED xx MILES AHEAD LOCAL TRAFFIC ONLY" Sign may be used in place of the R11-4 Sign.

PATA
 11C

PUBLICATION 213
 SHORT-TERM STATIONARY OPERATION
 TWO-LANE, TWO-WAY ROADWAY - ROAD CLOSURE

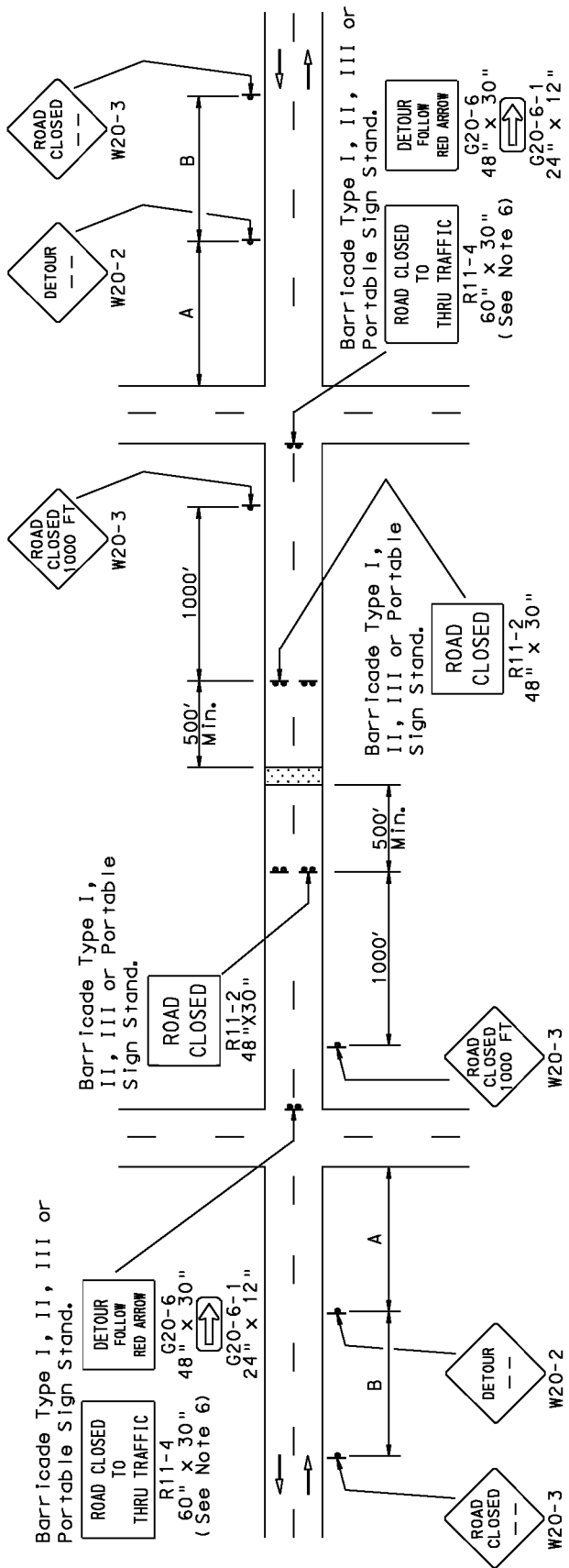

Distance plaques on Advance Warning signs shall be the same series type.
 Example: either all XXX ft. or all "AHEAD"
 CONDITION 1: All Highways (except Freeways and Expressways)
 A = 500 ft., W20-2 sign distance plaque to read 500 ft. or "AHEAD"
 B = 500 ft., W20-3 sign distance plaque to read 1000 ft. or "AHEAD"
 CONDITION 2: For Urban Streets
 A and B = 200 ft. and sign distance plaque to read "AHEAD"

NOTES

1. This figure applies for stationary operations where it is not feasible to maintain alternate one direction traffic flow.
2. This setup is to be used during daylight hours only and only on roadways with ADT's of 1500 or less.
3. Hours of work should not interfere with rush hour traffic or school bus schedules and the work site must be capable of accommodating emergency vehicles with as little delay as possible.
4. Roads used as alternate routes should be owned and maintained by the Commonwealth (Department projects only).
5. At locations where there are overlapping detours or several detours within the same area, street names may be added to the G20-6 and G20-6-1 signs, or signs with different colored arrows may be used to designate the different detour routes. The design and application of signs displaying colored arrows shall comply with 236M.
6. The R11-3A (60" x 30") "ROAD CLOSED xx MILES AHEAD LOCAL TRAFFIC ONLY" Sign may be used in place of the R11-4 Sign.

PUBLICATION 213
 SHORT-TERM STATIONARY OPERATION
 TWO-LANE, TWO-WAY ROADWAY - ROAD CLOSURE

Note:
 Barricade Type I, II, III or
 Portable Sign Stand may
 be used for all signs.

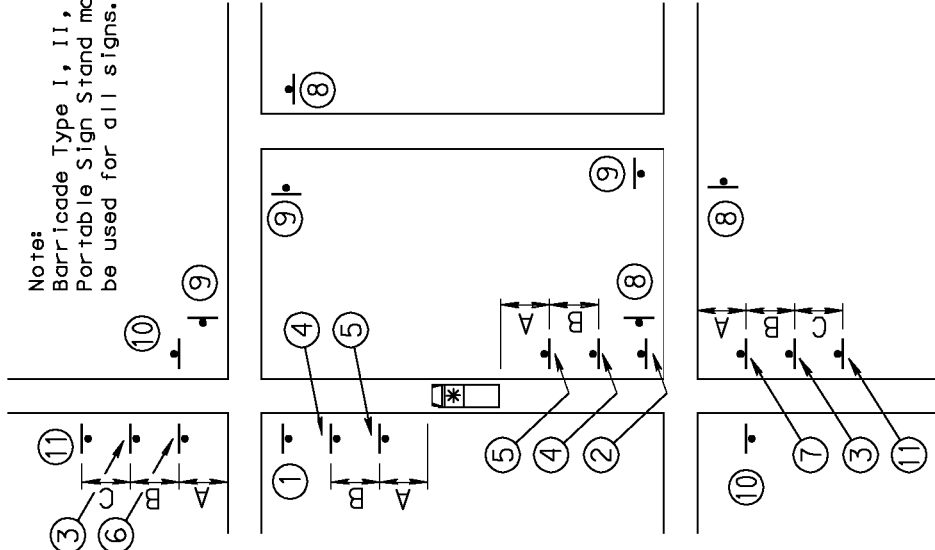

- ① ROAD CLOSED R11-2 48" x 30" M4-10L 36" x 12"
- ② ROAD CLOSED R11-2 48" x 30" M4-10R 36" x 12"
- ③ DETOUR W20-2
- ④ ROAD CLOSED W20-3
- ⑤ ROAD WORK W20-1
- ⑥ DETOUR M4-9SL 30" x 24"
- ⑦ DETOUR M4-9SR 30" x 24"
- ⑧ DETOUR M4-9L 30" x 24"
- ⑨ DETOUR M4-9R 30" x 24"
- ⑩ END DETOUR M4-8A 24" x 18"
- ⑪ ROAD CLOSED W20-3

Distance plaques on Advance Warning signs shall be the same series type.
 Example: either all XXX ft. or all "AHEAD"

CONDITION 1: All Highways (except Freeways and Expressways)
 A = 500 ft., #5, #6, and #7 sign distance plaque to read 500 ft. or "AHEAD"
 B = 500 ft., #3 and #4 sign distance plaque to read 1000 ft. or "AHEAD"
 C = 500 ft., #11 sign distance plaque to read 1500 ft. or "AHEAD"

CONDITION 2: For Urban Streets
 A, B and C = 200 ft. and all sign distance plaques to read "AHEAD"

NOTES

1. This figure applies for stationary operations where it is not feasible to maintain alternate one direction traffic flow.
2. This setup is to be used during daylight hours only and only on roadways with ADT's of 1500 or less.
3. Hours of work should not interfere with rush hour traffic or school bus schedules and the work site must be capable of accommodating emergency vehicles with as little delay as possible.
4. Roads used as alternate routes should be owned and maintained by the Commonwealth (Department projects only).
5. At locations where there are overlapping detours or several detours within the same area, street names may be added to the M4-9 series Signs, or signs with different colored arrows may be used to designate the different detour routes. The design and application of signs displaying colored arrows shall comply with 236M.

PUBLICATION 213
 SHORT-TERM MOBILE OPERATION
 TWO-LANE, TWO-WAY ROADWAY OR ONE-LANE APPROACH OF A THREE-LANE, TWO-WAY ROADWAY

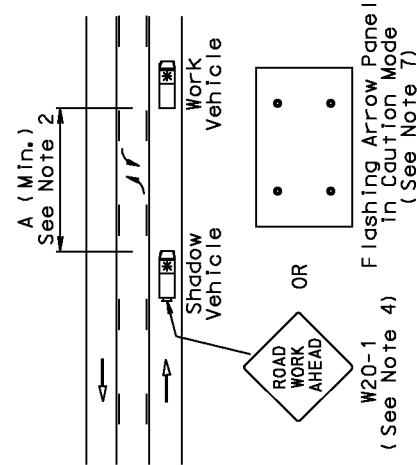
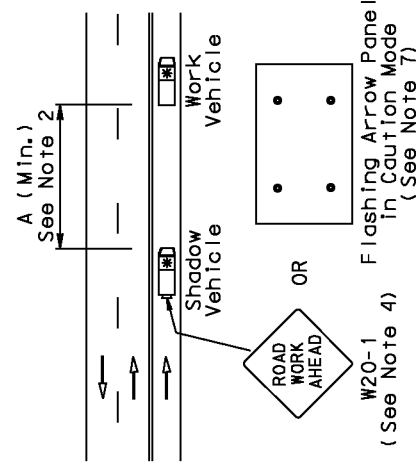
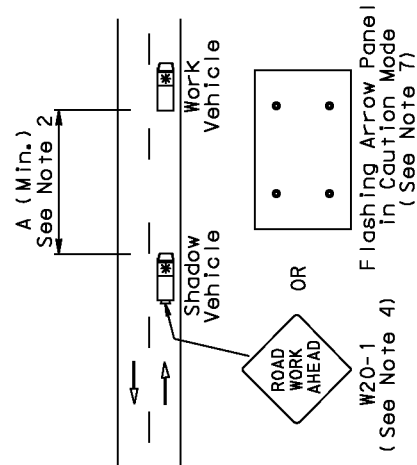

CONDITION 1: All Highways (except Freeways and Expressways)
 A = 10 times the normal speed limit.

CONDITION 2: For Urban Streets
 A = 200 ft.

NOTES

1. This figure applies for operations that move intermittently or continuously at an average speed of 1 MPH or more.
2. The shadow vehicle shall be positioned so that it is visible from behind for a minimum distance of A. The shadow vehicle should slow down in advance of vertical or horizontal curves that restrict sight distance.
3. Where passing is not permitted for extended lengths, the shadow and work vehicles should pull over periodically, when it is reasonable and safe, in order to allow "backed-up" or queued traffic to resume its normal speed.
4. Other appropriate standard signs may be used instead of the W20-1 Sign.
5. The shadow vehicle should be equipped with two high-intensity flashing lights mounted on the rear, adjacent to the sign.
6. A truck-mounted attenuator may be used on the shadow vehicle and/or on the work vehicle.
7. See PATA GENERAL, Table 5 for size of the Flashing Arrow Panel.

PUBLICATION 213
 SHORT-TERM STATIONARY OPERATION
 THREE-LANE, TWO-WAY ROADWAY WITH PASSING - WORK AREA IN THE SINGLE APPROACH

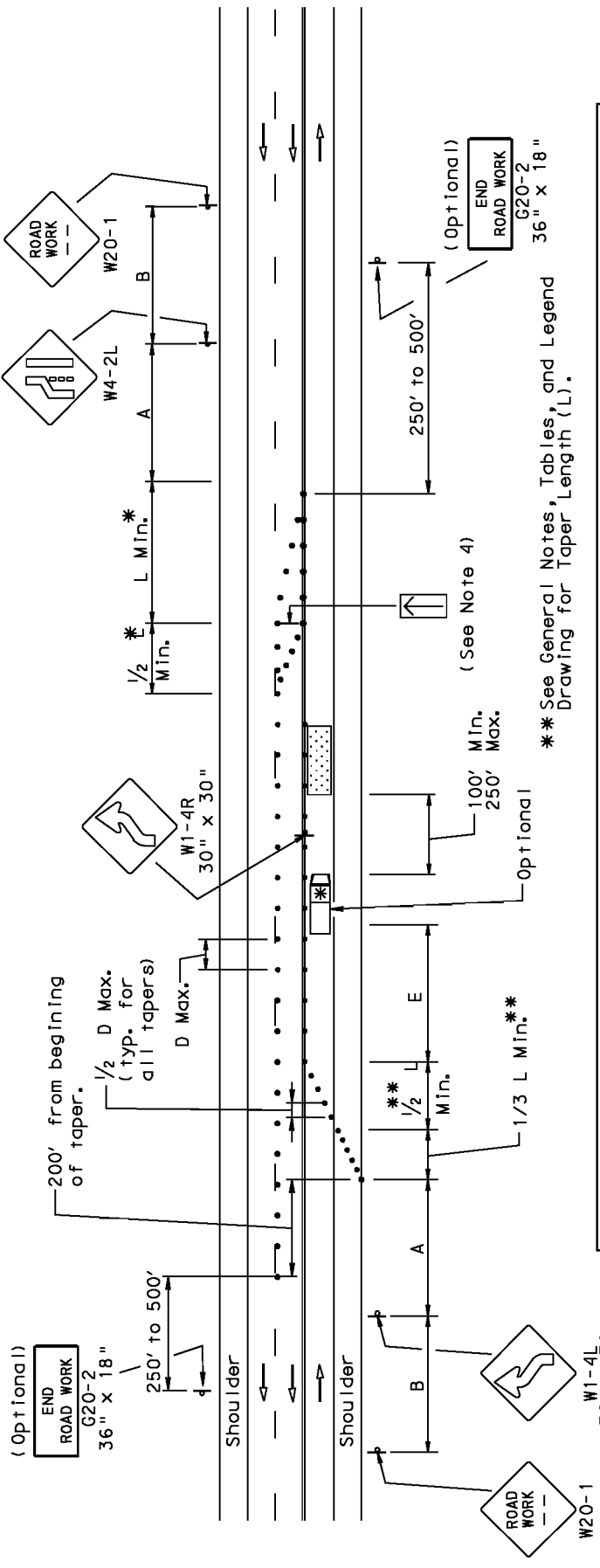

Distance plaques on Advance Warning signs shall be the same series type.
 Example: either all XXX ft. or all "AHEAD"
 CONDITION 1: All Highways (except Freeways and Expressways)
 A = 500 ft.
 B = 500 ft., W20-1 sign distance plaque to read 1000 ft. or "AHEAD"
 CONDITION 2: For Urban Streets
 A and B = 200 ft. and sign distance plaque to read "AHEAD"

All Highways (except freeway and expressway)		
MPH	D ft	E* ft
25	50	155
30	60	200
35	70	250
40	80	305
45	90	360
50	100	425
55	110	495

* Distances may be increased for downgrades or other conditions that affect stopping sight distance.

NOTES

- When paved shoulders having a width of 8 ft or more are closed, channelizing devices should be used to close the shoulder in advance of the shifting taper.
- When a highway-rail grade crossing exists within the work zone, or it is anticipated that queues resulting from the lane closure might extend through a highway-rail grade crossing, provisions shall be made to eliminate conflicts, which may require placing a flagger at the crossing. Coordination with the railroad is essential.
- If the length of the tangent section between beginning and ending tapers is more than 600 ft, use two W1-4 Signs as shown. If the distance is 600 ft or less, use a W24-1 Sign.
- See PATA GENERAL, Table 5 for size of the Flashing Arrow Panel.

PATA
13a

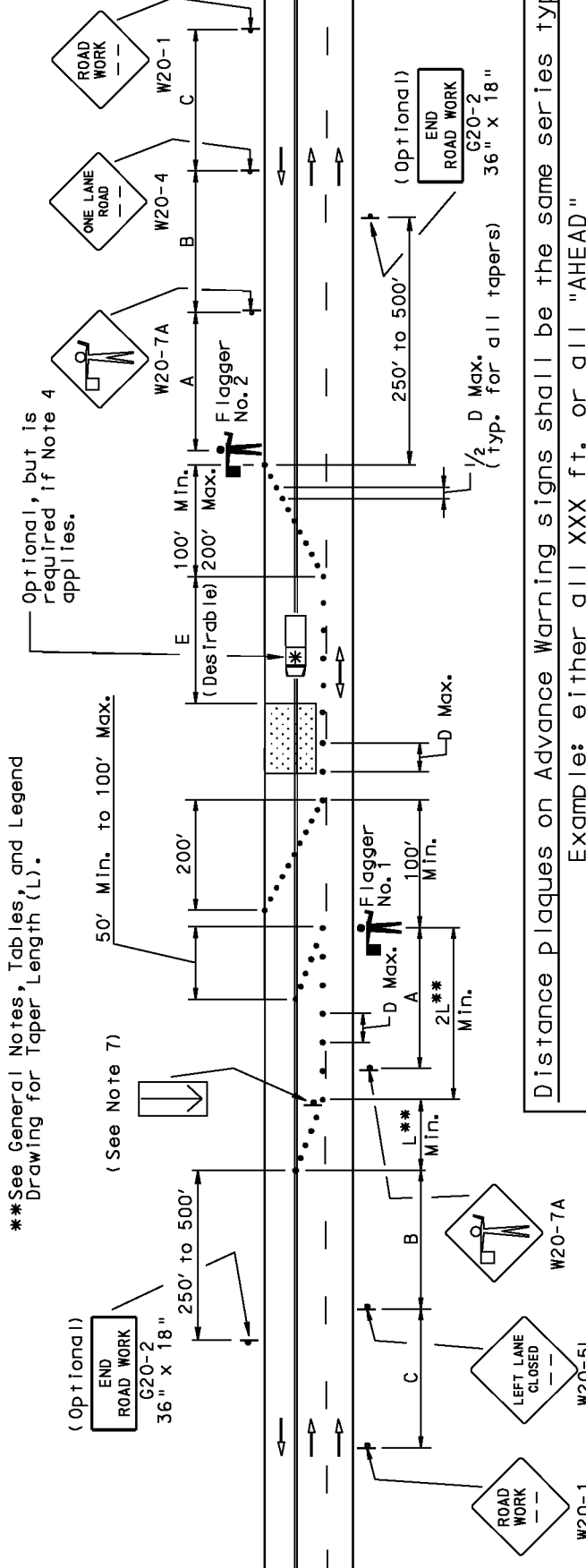

**See General Notes, Tables, and Legend Drawing for Taper Length (L).

(See Note 7)

Optional, but is required if Note 4 applies.

Distance plaques on Advance Warning signs shall be the same series type.
 Example: either all XXX ft. or all "AHEAD"

CONDITION 1: All Highways (except Freeways and Expressways)
 A = 500 ft.
 B = 500 ft., W20-4 and W20-5L sign distance plaque to read 1000 ft. or "AHEAD"
 C = 500 ft., W20-1 sign distance plaque to read 1500 ft. or "AHEAD"

CONDITION 2: For Urban Streets
 A, B and C = 200 ft. and sign distance plaque to read "AHEAD"

All Highways (except freeway and expressway)

MPH	D		E*	
	ft	ft	ft	ft
25	50	155		
30	60	200		
35	70	250		
40	80	305		
45	90	360		
50	100	425		
55	110	495		

*Distances may be increased for downgrades or other conditions that affect stopping sight distance.

NOTES

- All flaggers must be in communication with each other.
- Each flagger should be clearly visible to traffic for a minimum distance of E.
- At night, flagger stations shall be illuminated, except in emergencies. See General Notes, sheet 3, note 26.
- For operations of 15 minutes or less:
 - The W20-1 and W20-4 Signs are not required.
 - All channelizing devices may be eliminated if two vehicles with an activated flashing or revolving yellow light is present in advance of the work space.
 - The W20-7A Sign may be eliminated if the flagger is clearly visible to traffic for a minimum distance of E.
- The buffer space should be extended so that the two-way traffic taper is placed before a horizontal (or crest vertical) curve to provide adequate sight distance for the flagger and a queue of stopped vehicles.
- When a highway-rail grade crossing exists within the work zone, or it is anticipated that queues resulting from the lane closure might extend through a highway-rail grade crossing, provisions shall be made to eliminate conflicts, which may require placing a flagger at the crossing. Coordination with the railroad is essential.
- See PATA GENERAL, Table 5 for size of the Flashing Arrow Panel.

PUBLICATION 213
 SHORT-TERM STATIONARY OPERATION - THREE-LANE, TWO-WAY ROADWAY WITH
 A CENTER LANE, LEFT TURN ONLY PATTERN - WORK AREA IN ONE OF THE THROUGH LANES

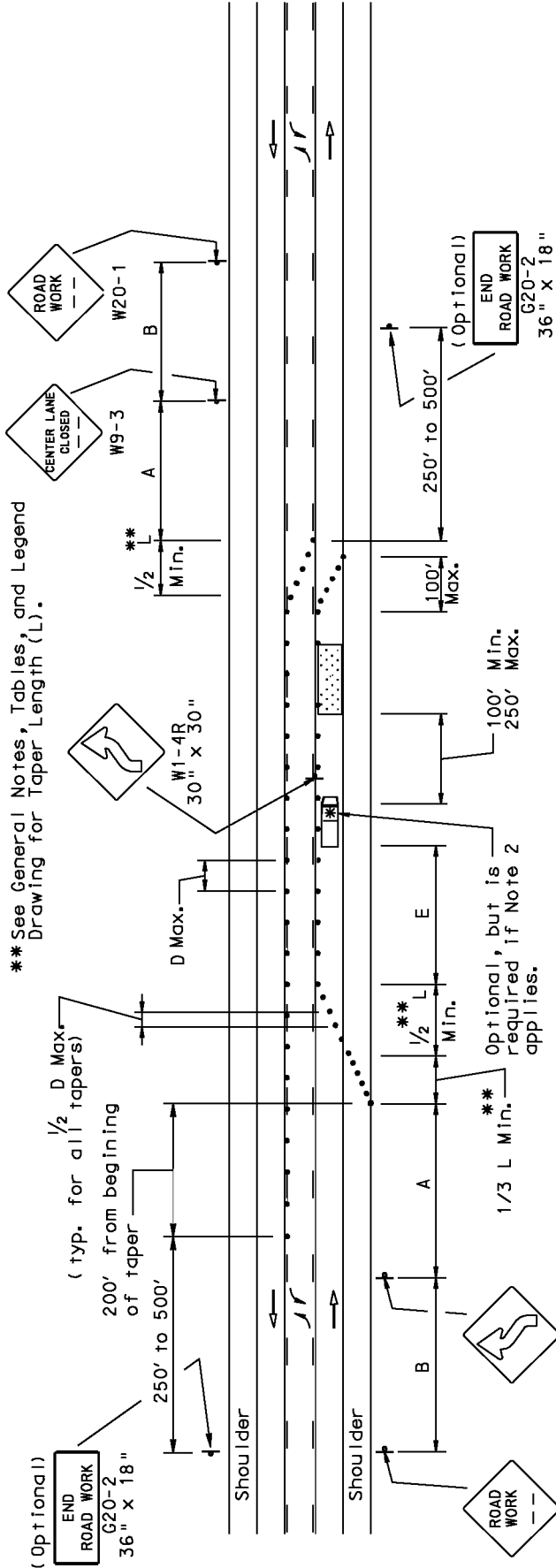

** See General Notes, Tables, and Legend Drawing for Taper Length (L).

(Optional)
 END ROAD WORK
 G20-2
 36" x 18"

1/2 D Max.
 (typ. for all tapers)
 200' from beginning of taper
 250' to 500'

ROAD WORK
 W20-1

W1-4R
 30" x 30"

W1-4L
 30" x 30"

END ROAD WORK
 G20-2
 36" x 18"

250' to 500' (Optional)

100' Max.

100' Min.
 250' Max.

Distance plaques on Advance Warning signs shall be the same series type.
 Example: either all XXX ft. or all "AHEAD"

CONDITION 1: All Highways (except Freeways and Expressways)
 A = 500 ft.
 B = 500 ft., W20-1 sign distance plaque to read 1000 ft. or "AHEAD"

CONDITION 2: For Urban Streets
 A and B = 200 ft. and sign distance plaque to read "AHEAD"

NOTES

- When paved shoulders having a width of 8 ft or more are closed, channelizing devices should be used to close the shoulder in advance of the shifting taper.
- For operations of 15 minutes or less:
 - The W20-1, W9-3, W1-4L, and W1-4R Signs are not required.
 - All channelizing devices may be eliminated if a vehicle with an activated flashing or revolving yellow light is present in advance of the work space.
- When a highway-rail grade crossing exists within the work zone, or it is anticipated that queues resulting from the lane closure might extend through a highway-rail grade crossing, provisions shall be made to eliminate conflicts, which may require placing a flagger at the crossing. Coordination with the railroad is essential.
- If the length of the tangent section between beginning and ending tapers is more than 600 ft, use two W1-4 Signs as shown. If the distance is 600 ft or less, use a W24-1 Sign.
- Where speed or volume is higher, signing such as additional Left Lane Closed XX ft Sign (W20-5L) or Be Prepared To Stop Sign (W3-4) should be used in advance of the W20-1 sign.

All Highways (except freeway and expressway)		
MPH	D	E*
25	50	155
30	60	200
35	70	250
40	80	305
45	90	360
50	100	425
55	110	495

*Distances may be increased for downgrades or other conditions that affect stopping sight distance.

PUBLICATION 213
 SHORT-TERM STATIONARY OPERATION OR MOBILE OPERATION
 WORK AREA IN A TWO-WAY LEFT TURN LANE

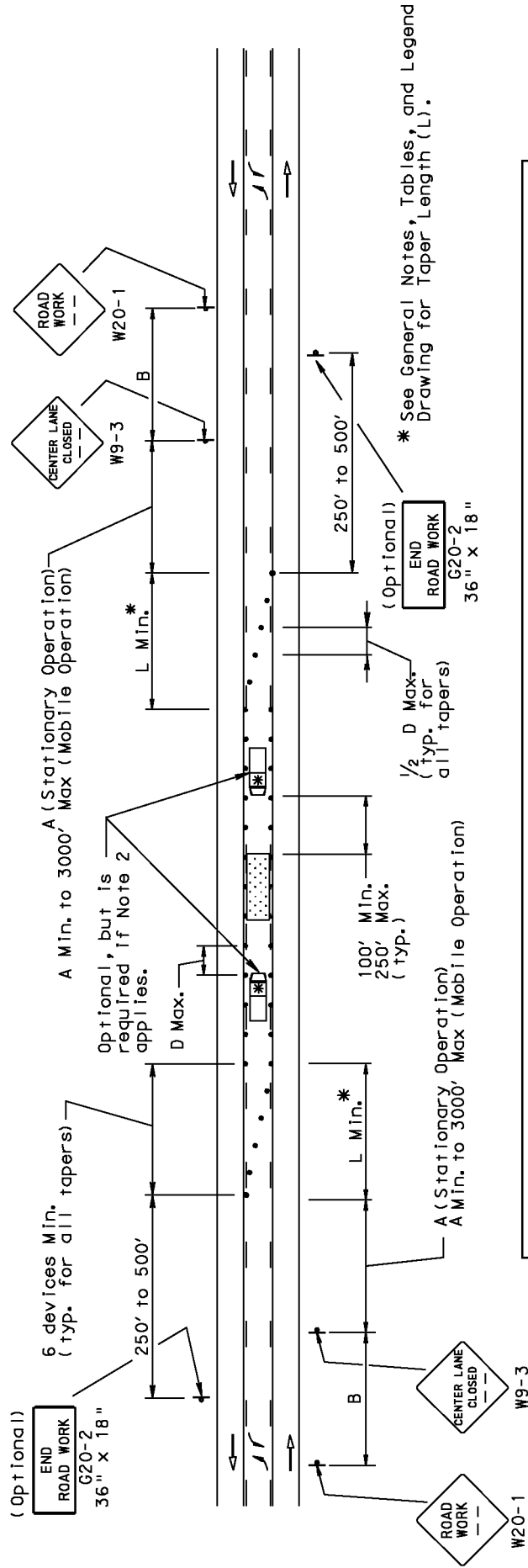

Distance plaques on Advance Warning signs shall be the same series type.
 Example: either all XXX ft. or all "AHEAD"

CONDITION 1: All Highways (except Freeways and Expressways)
 A = 500 ft., W9-3 sign distance plaque to read 500 ft. or "AHEAD"
 B = 500 ft., W20-1 sign distance plaque to read 1000 ft. or "AHEAD"
 D = 2 times the normal speed limit

CONDITION 2: For Urban Streets
 A and B = 200 ft. and sign distance plaque to read "AHEAD"
 D = 2 times the normal speed limit

NOTES

- For stationary operations 60 minutes or less, or for mobile operations that move intermittently or continuously at an average speed of 1 MPH or less, a taper is not required if a vehicle with an activated flashing or revolving yellow light is located in advance of the work space.
- For operations of 15 minutes or less:
 - The W20-1 and W9-3 Signs are not required.
 - All channelizing devices may be eliminated if a vehicle with an activated flashing or revolving yellow light is present in advance of the work space.
- When a highway-rail grade crossing exists within the work zone, or it is anticipated that queues resulting from the lane closure might extend through a highway-rail grade crossing, provisions shall be made to eliminate conflicts, which may require placing a flagger at the crossing. Coordination with the railroad is essential.
- Where speed or volume is higher, signing such as additional Center Lane Closed XX ft Sign (W9-3) or Be Prepared To Stop Sign (W3-4) should be used in advance of the W20-1 sign.

PUBLICATION 213
 SHORT-TERM STATIONARY OPERATION OR MOBILE OPERATION
 MULTILANE, UNDIVIDED HIGHWAY - WORK AREA IN THE LEFT OR RIGHT LANE

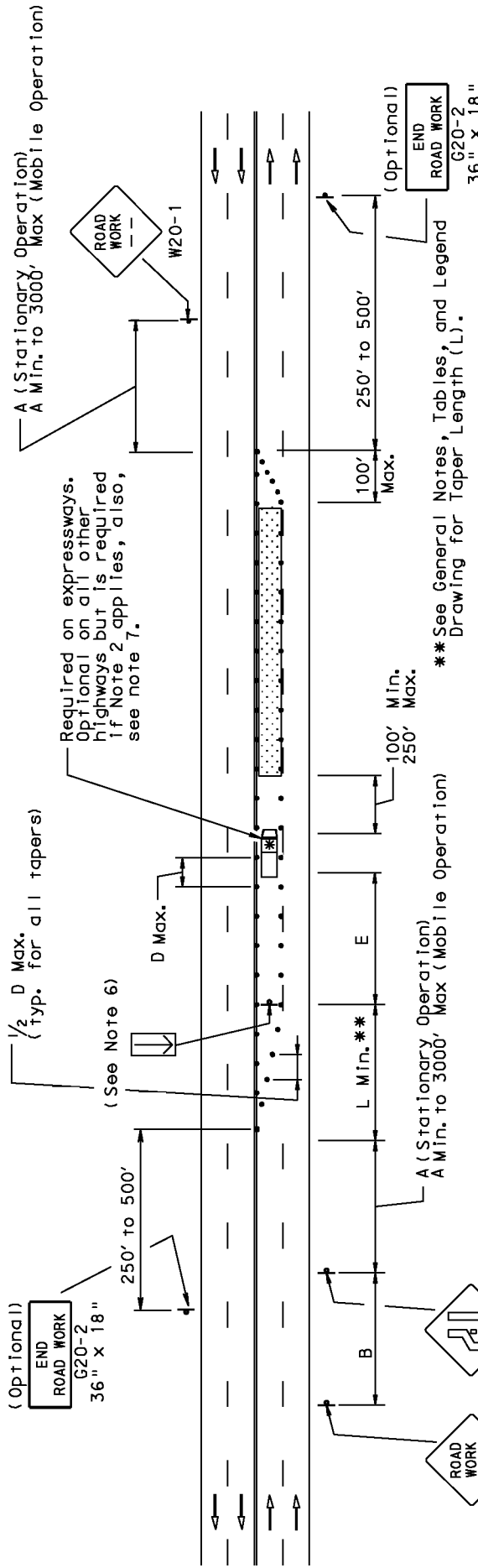

Distance plaques on Advance Warning signs shall be the same series type.
 Example: either all XXX ft. or all "AHEAD"

- CONDITION 1: All Highways (except Freeways and Expressways)
 A = 500 ft.
 B = 500 ft., W20-1 sign distance plaque to read 1000 ft. or "AHEAD"
- CONDITION 2: For Urban Streets
 A and B = 200 ft. and sign distance plaque to read "AHEAD"

NOTES

- For right lane closures, signs in the opposite direction of travel are not required.
- For operations 15 minutes or less:
 - The W20-1, W9-3 and W1-4R Signs are not required.
 - All channelizing devices may be eliminated if a vehicle with an activated flashing or revolving yellow light is present in advance of the work space.
- For stationary operations 60 minutes or less in duration, or for mobile operations that move intermittently or continuously at an average speed of 1 MPH or less,
 - The W20-1 Sign in the opposite direction of travel is not required.
- When a highway-rail grade crossing exists within the work zone, or it is anticipated that queues resulting from the lane closure might extend through a highway-rail grade crossing, provisions shall be made to eliminate conflicts, which may require placing a flagger at the crossing. Coordination with the railroad is essential.
- Where speed or volume is higher, signing such as additional Left Lane Closed XX ft Sign (W20-5L) or Be Prepared to Stop Sign (W3-4) should be used in advance of the W20-1 sign.
- See PATA GENERAL, Table 5 for size of the Flashing Arrow Panel.
- Shadow vehicle shall be equipped with a Truck Mounted Attenuator (TMA) on expressways and optional on all other highways.

All Highways (except freeways and expressways)			
MPH	D	E *	E *
25	50	155	ft
30	60	200	
35	70	250	
40	80	305	
45	90	360	
50	100	425	
55	110	495	
Expressways			
50	100	425	
55	110	495	
60	120	570	
65	130	645	

* Distances may be increased for downgrades or other conditions that affect stopping sight distance.

PUBLICATION 213
 SHORT-TERM STATIONARY OPERATION - FOUR-LANE, UNDIVIDED HIGHWAY
 WORK AREA REQUIRING THE CLOSURE OF ONE SIDE OF THE ROADWAY

** See General Notes, Tables, and Legend Drawing for Taper Length (L).

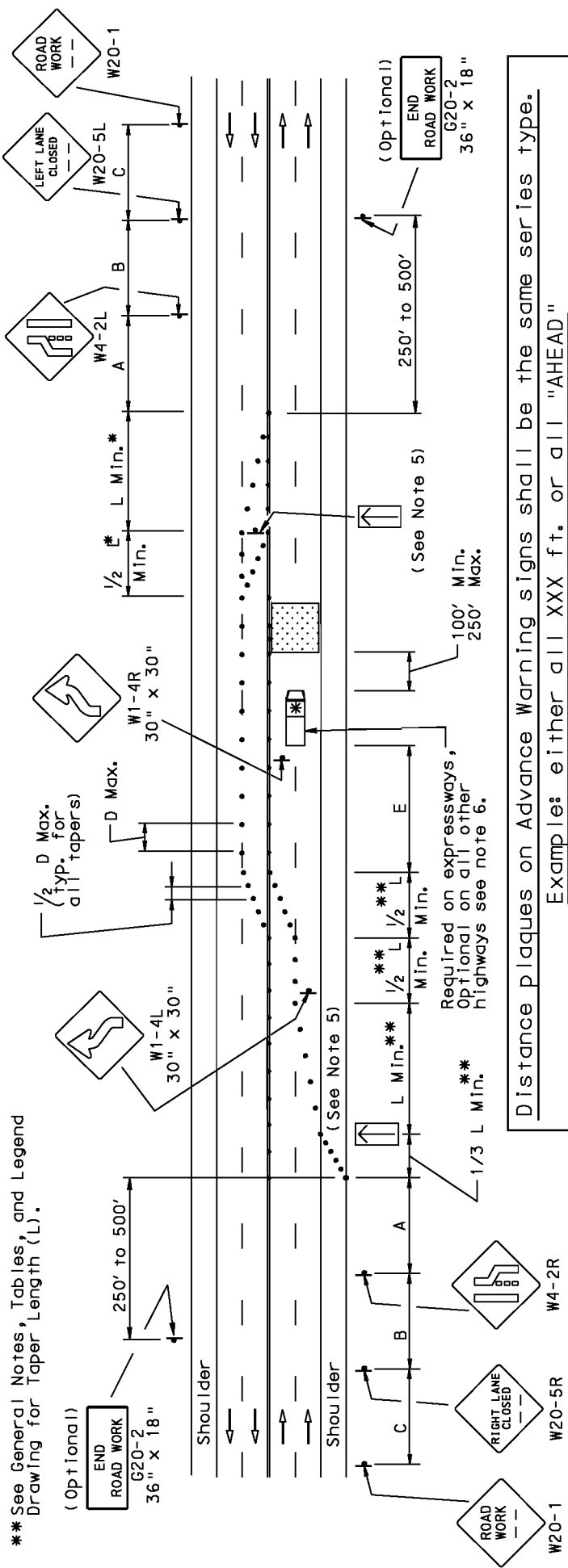

(Optional)
 END ROAD WORK
 G20-2
 36" x 18"

250' to 500'

Shoulder

Shoulder

(See Note 5)

L Min. **

1/2 L Min. **

1/2 L Min. *

100' Min.
 250' Max.

250' to 500'

(Optional)
 END ROAD WORK
 G20-2
 36" x 18"

All Highways (except freeways and expressways)		
MPH	D	E *
25	50	155
30	60	200
35	70	250
40	80	305
45	90	360
50	100	425
55	110	495
Expressways		
50	100	425
55	110	495
60	120	570
65	130	645

* Distances may be increased for downgrades or other conditions that affect stopping sight distance.

Distance plaques on Advance Warning signs shall be the same series type.
 Example: either all XXX ft. or all "AHEAD"

CONDITION 1: All Highways (except Freeways and Expressways)
 A = 500 ft.
 B = 500 ft., W20-5R sign distance plaque to read 1000 ft. or "AHEAD"
 C = 500 ft., W20-1 sign distance plaque to read "AHEAD"

CONDITION 2: For Urban Streets
 A, B and C = 200 ft. and sign distance plaque to read "AHEAD"

CONDITION 3: For Expressways Highways
 A = 1000 ft.
 B = 1640 ft., W20-5R and W20-5L sign distance plaque to read 1/2 MILE or "AHEAD"
 C = 2640 ft., W20-1 sign distance plaque to read 1 MILE or "AHEAD"

NOTES

- When paved shoulders having a width of 8 ft or more are closed, channelizing devices should be used to close the shoulder in advance of the merging taper.
- When a highway-rail grade crossing exists within the work zone, or it is anticipated that queues resulting from the lane closure might extend through a highway-rail grade crossing, provisions shall be made to eliminate conflicts, which may require placing a flagger at the crossing. Coordination with the railroad is essential.
- If the length of the tangent section between beginning and ending tapers is more than 600 ft, use two W1-4 Signs as shown. If the distance is 600 ft or less, use a W24-1 Sign.
- Where speed or volume is higher, signing such as additional Left Lane Closed XX ft Sign (W20-5L), Right Lane Closed XX ft Sign (W20-5R) or Be Prepared To Stop Sign (W3-4) should be used in advance of the W20-1 sign.
- See PATA GENERAL, Table 5 for size of the Flashing Arrow Panel.
- Shadow vehicle shall be equipped with a Truck Mounted Attenuator (TMA) on expressways and optional on all other highways.

PUBLICATION 213
 SHORT-TERM STATIONARY OPERATION OR MOBILE OPERATION
 DIVIDED OR ONE-WAY HIGHWAY - WORK AREA IN THE LEFT OR RIGHT LANE

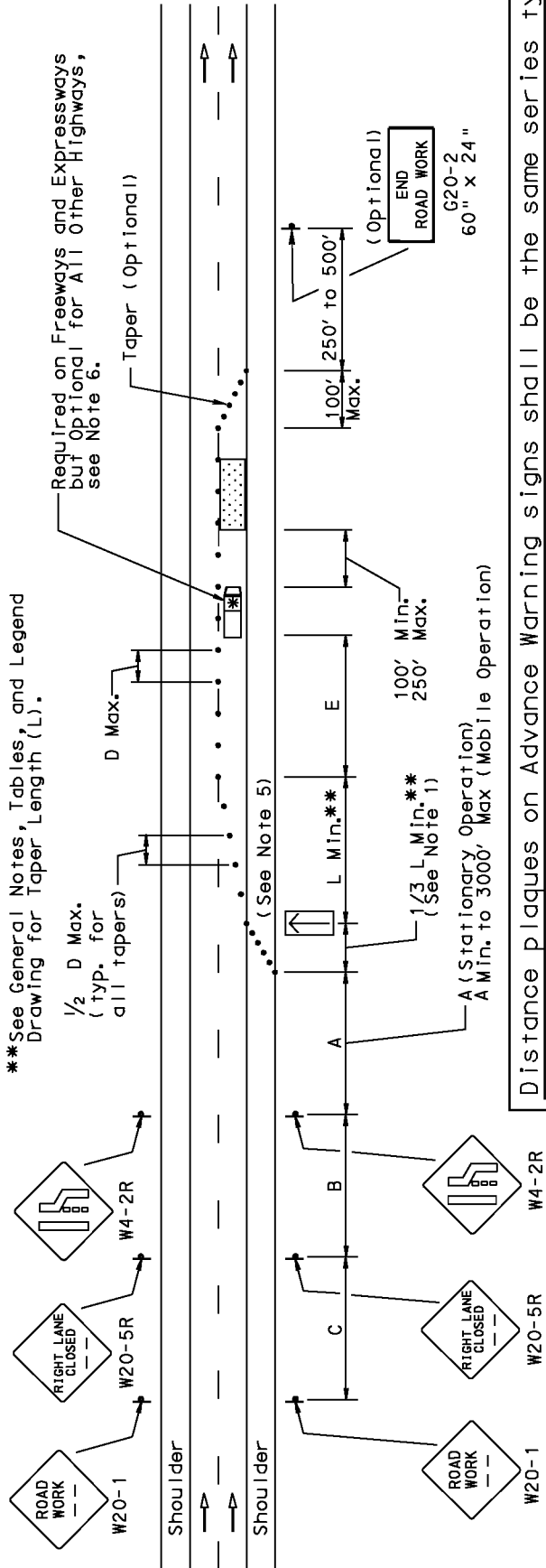

** See General Notes, Tables, and Legend Drawing for Taper Length (L).

1/2 D Max. (typ. for all tapers)

Required on Freeways and Expressways but Optional for All Other Highways, see Note 6.

Taper (Optional)

(See Note 5)

100' Max.
 250' to 500'
 (Optional)
 END ROAD WORK
 G20-2
 60" x 24"

100' Min.
 250' Max.

A (Stationary Operation)
 A Min. to 3000' Max (Mobile Operation)

1/3 L Min. (See Note 1)

Example: either all XXX ft. or all "AHEAD"

CONDITION 1: All Highways (except Freeways and Expressways)
 A = 500 ft.
 B = 500 ft., W20-5R sign distance plaque to read 1000 ft. or "AHEAD"
 C = 500 ft., W20-1 sign distance plaque to read 1500 ft. or "AHEAD"

CONDITION 2: For Urban Streets
 A, B and C = 200 ft. and sign distance plaque to read "AHEAD"

CONDITION 3: For Freeway and Expressway Highways
 A = 1000 ft.
 B = 1640 ft., W20-5R sign distance plaque to read 1/2 MILE or "AHEAD"
 C = 2640 ft., W20-1 sign distance plaque to read 1 MILE or "AHEAD"

NOTES

- When paved shoulders having a width of 8 ft or more are closed, channelizing devices should be used to close the shoulder in advance of the merging taper.
- For left lane closures, the W20-5L Sign shall be used instead of the W20-5R Sign.
- When a highway-rail grade crossing exists within the work zone, or it is anticipated that queues resulting from the lane closure might extend through a highway-rail grade crossing, provisions shall be made to eliminate conflicts, which may require placing a flagger at the crossing. Coordination with the railroad is essential.
- Where speed or volume is higher, signing such as additional Right Lane Closed XX ft Sign (W20-5R) or Be Prepared to Stop Sign (W3-4) should be used in advance of the W20-1 sign.
- See PATA GENERAL, Table 5 for size of the Flashing Arrow Panel.
- Shadow vehicle shall be equipped with a Truck Mounted Attenuator (TMA) on Expressways and Freeways. Use of a TMA is optional on all other Highways when a shadow vehicle is used.

All Highways (except freeways and expressways)	E*	
	D	E*
MPH	ft	ft
25	50	155
30	60	200
35	70	250
40	80	305
45	90	360
50	100	425
55	110	495
Freeways and Expressways		
50	100	425
55	110	495
60	120	570
65	130	645

* Distances may be increased for downgrades or other conditions that affect stopping sight distance.

PUBLICATION 213
SHORT-TERM STATIONARY OPERATION
THREE-LANE, ONE-WAY ROADWAY - WORK AREA IN THE CENTER LANE

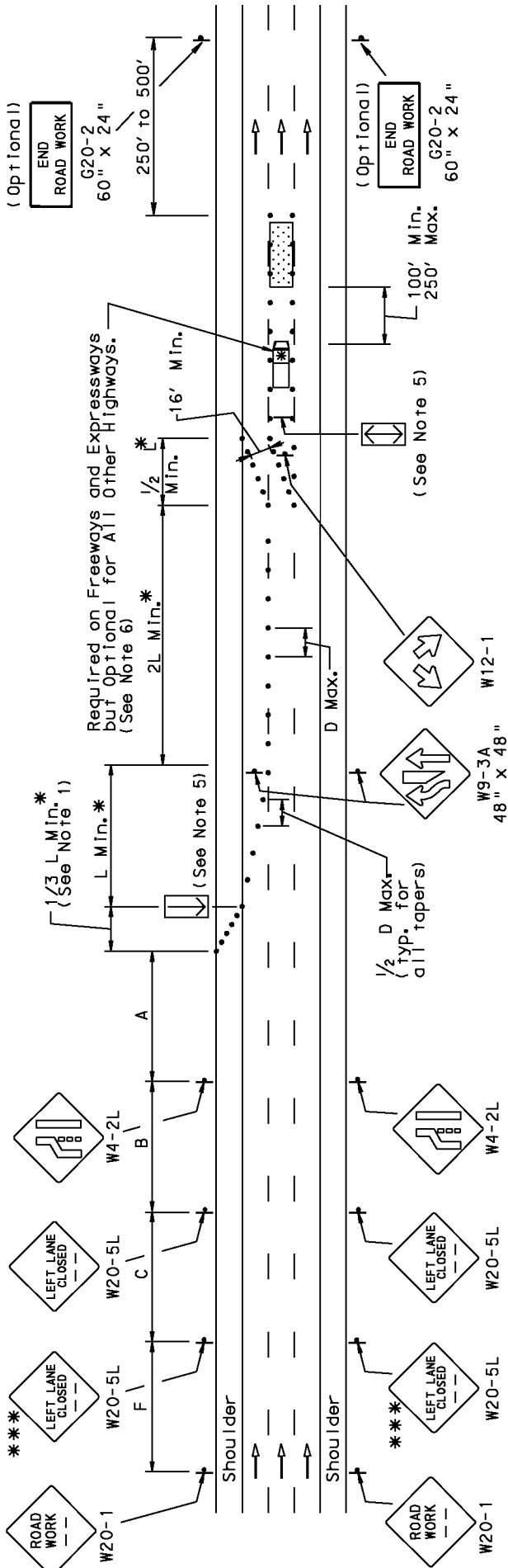

Distance plaques on Advance Warning signs shall be the same series type.
Example: either all XXX ft. or all "AHEAD"

- CONDITION 1:** All Highways (except Freeways and Expressways)
 A = 500 ft.
 B = 1000 ft., W20-5L sign distance plaque to read 1500 ft. or "AHEAD".
 C = 1140 ft., W20-1 sign distance plaque to read 1/2 Mile or "AHEAD".
 If speeds are less than 45 MPH.
 D = 2 times the normal speed limit.
 F = 1/2 Mile, W20-1 sign distance plaque to read 1 Mile or "AHEAD".
 (If second W20-5L is eliminated, F will be 1140 ft., and the W20-1 sign distance plaque to read 1/2 Mile or "AHEAD")
- CONDITION 2:** For Urban Streets
 A, B and F = 200 ft. and sign distance plaque to read "AHEAD"
 (Distance C and the second W20-5AR sign may be eliminated)
 D = 2 times the normal speed limit.
- CONDITION 3:** For Freeway and Expressway Highways
 A = 1000 ft.
 B = 1640 ft., W20-5L sign distance plaque to read 1/2 MILE or "AHEAD"
 C = 2640 ft., W20-1 sign distance plaque to read 1 MILE or "AHEAD"
 D = 2 times the normal speed limit.

NOTES

1. When paved shoulders having a width of 8 ft or more are closed, channelizing devices should be used to close the shoulder in advance of the merging taper.
2. A reversed pattern, beginning with a right lane closure, may also be used.
3. If a paved shoulder having a minimum width of 10 ft and sufficient strength is available, the left and center lanes may be closed and motor vehicle traffic carried around the work space on the right lane and a right shoulder. When a shoulder lane is used that cannot adequately accommodate trucks, trucks may be directed to use the normal travel lanes.
4. Where speed or volume is higher, signing such as additional Left Lane Closed XX ft Sign (W20-5L) or Be Prepared To Stop Sign (W3-4) should be used in advance of the W20-1 sign.
5. See PATA GENERAL, Table 5 for size of the Flashing Arrow Panel.
6. Shadow vehicle shall be equipped with a Truck Mounted Attenuator (TMA) on Expressways and Freeways. Use of a TMA is Optional on all other Highways when a shadow vehicle is used.

**BLANK
PAGE**

PUBLICATION 213
SHORT-TERM STATIONARY OPERATION
DIVIDED OR ONE-WAY HIGHWAY - WORK AREA IN TWO ADJACENT LANES

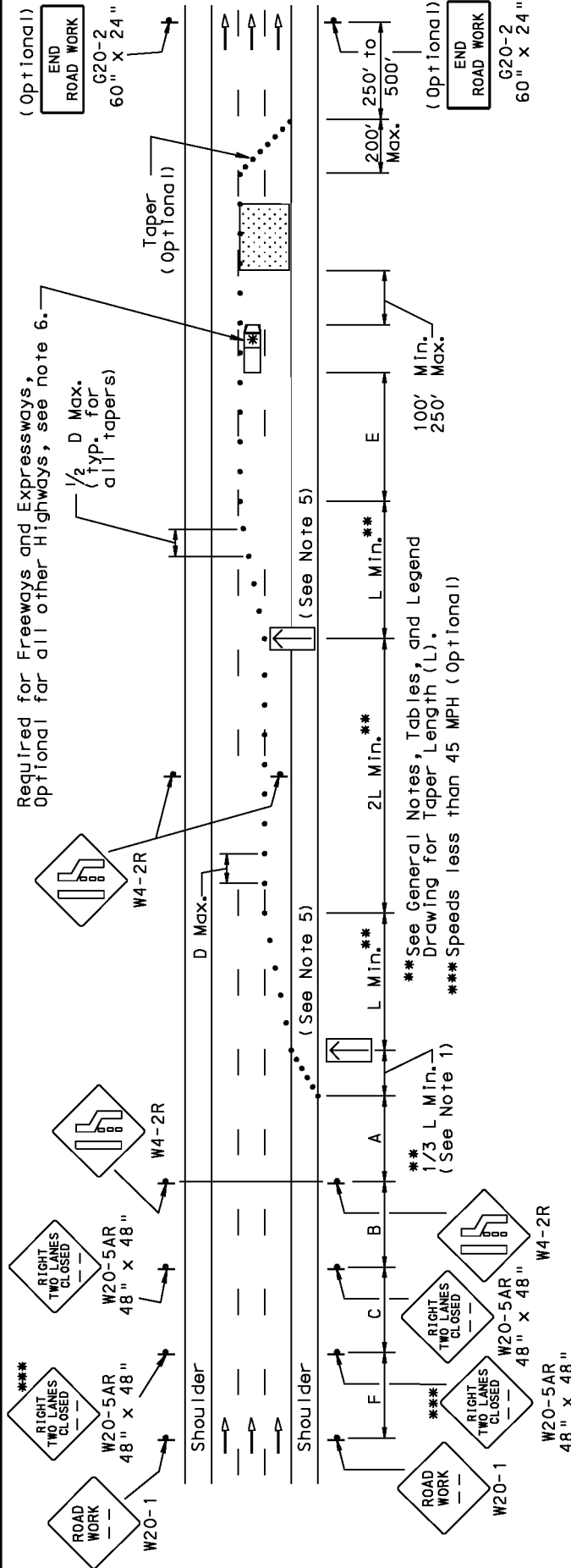

MPH	All Highways (except freeways and expressways)	
	D	E*
25	50	155
30	60	200
35	70	250
40	80	305
45	90	360
50	100	425
55	110	495
Expressways		
50	100	425
55	110	495
60	120	570
65	130	645

*Distances may be increased for downgrades or other conditions that affect stopping sight distance.

Distance plaques on Advance Warning signs shall be the same series type.

Example: either all XXX ft. or all "AHEAD"

CONDITION 1: All Highways (except Freeways and Expressways)

- A = 500 ft.
 - B = 1000 ft., W20-5AR sign distance plaque to read 1500 ft. or "AHEAD"
 - C = 1140 ft., W20-5AR sign distance plaque to read 1/2 MILE or "AHEAD"
 - F = 2640 ft., W20-1 sign distance plaque to read 1 MILE or "AHEAD".
- (If sign is eliminated, F will be 1140 ft., and the W20-1 sign distance plaque to read 1/2 MILE or "AHEAD")

CONDITION 2: For Urban Streets

- A, B, C and F = 200 ft. and sign distance plaque to read "AHEAD"

CONDITION 3: For Freeway and Expressway Highways

- A = 1000 ft.
- B = 1640 ft., W20-5AR sign distance plaque to read 1/2 MILE or "AHEAD"
- C = 2640 ft., W20-5AR sign distance plaque to read 1 MILE or "AHEAD"
- F = 1 MILE, W20-1 sign distance plaque to read 2 MILES or "AHEAD"

PATA
20

PUBLICATION 213
SHORT-TERM STATIONARY OPERATION
DIVIDED OR ONE-WAY HIGHWAY - WORK AREA IN TWO ADJACENT LANES

NOTES

1. When paved shoulders having a width of 8 ft or more are closed, channelizing devices should be used to close the shoulder in advance of the merging taper.
2. If the two left lanes are closed, the Left Two Lanes Closed Ahead Sign (W20-5AL) shall be used instead of the W20-5AR Sign.
3. Where speed or volume is higher, signing such as additional Right Two Lanes Closed XX ft Sign (W20-5AR) or Be Prepared To Stop Sign (W3-4) should be used in advance of the W20-1 sign.
4. When a highway-rail grade crossing exists within the work zone, or it is anticipated that queues resulting from the lane closure might extend through a highway-rail grade crossing, provisions shall be made to eliminate conflicts, which may require placing a flagger at the crossing. Coordination with the railroad is essential.
5. See PATA GENERAL, Table 5 for size of the Flashing Arrow Panel.
6. Shadow vehicle shall be equipped with a Truck Mounted Attenuator (TMA) on Expressways and Freeways. Use of a TMA is Optional on all other Highways when a shadow vehicle is used.

PUBLICATION 213
SHORT-TERM STATIONARY OPERATION
LANE CLOSURE NEAR A FREEWAY OR EXPRESSWAY EXIT RAMP

* See General Notes, Tables, and Legend
Drawing for Taper Length (L).

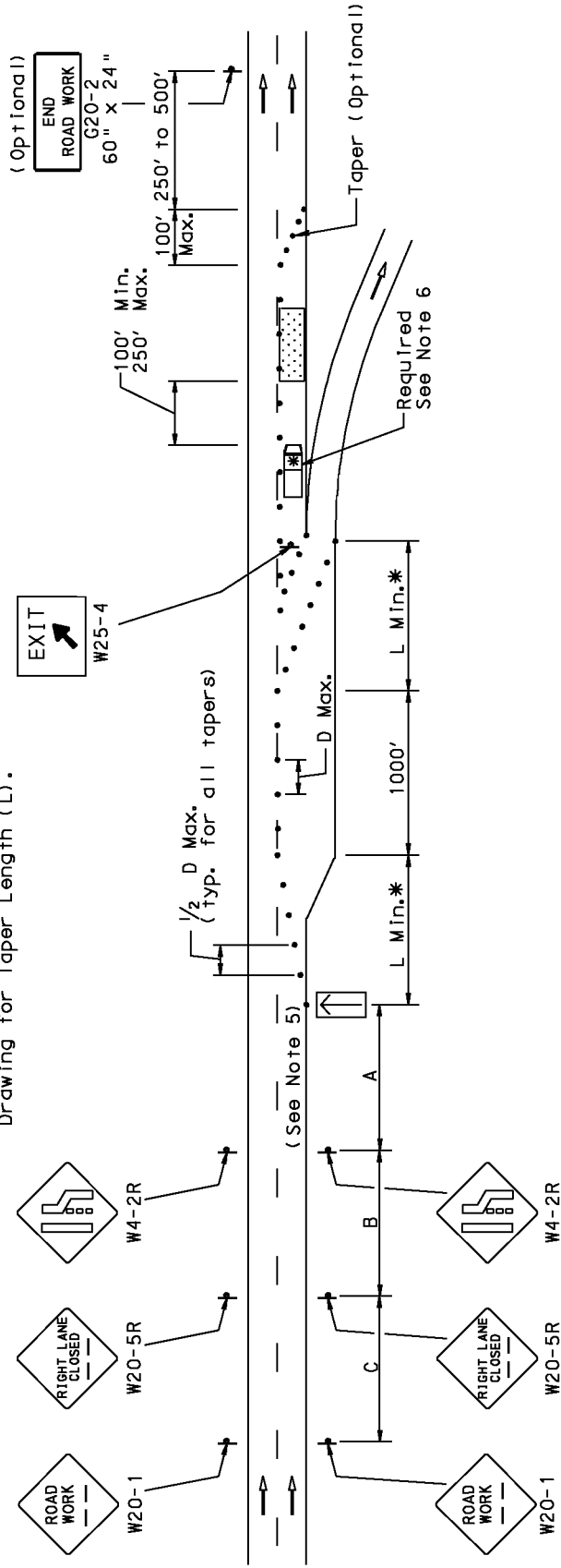

Distance plaques on Advance Warning signs shall be the same series type.

Example: either all XXX ft. or all "AHEAD"

- A = 1000 ft.
- B = 1640 ft., W20-5R sign distance plaque to read 1/2 MILE or "AHEAD"
- C = 2640 ft., W20-1 sign distance plaque to read 1 MILE or "AHEAD"
- D = 2 times the normal speed limit.

NOTES

1. In locations with heavy ramp traffic, the channelizing devices in advance of the ramp may be eliminated if special advance signing is erected to indicate that the right lane is a mandatory exit only lane.
2. The temporary EXIT sign shall be located in the temporary gore. It shall be mounted a minimum of 3 ft. from the pavement surface to the bottom of the sign.
3. The guide signs should indicate that the ramp is open, and where the temporary ramp is located. However, if the ramp is closed, guide signs should indicate that the ramp is closed.
4. When the exit ramp is closed, a black on orange EXIT CLOSED panel should be placed diagonally across the interchange/intersection guide signs.
5. See PATA GENERAL, Table 5 for size of the Flashing Arrow Panel.
6. Shadow vehicle shall be equipped with a Truck Mounted Attenuator (TMA).
7. Where speed or volume is higher, signing such as additional Right Lane Closed XX ft Sign (W20-5R) or Be Prepared To Stop Sign (W3-4) should be used in advance of the W20-1 sign.

PUBLICATION 213
 SHORT-TERM STATIONARY OPERATION
 WORK SPACE ON A RAMP

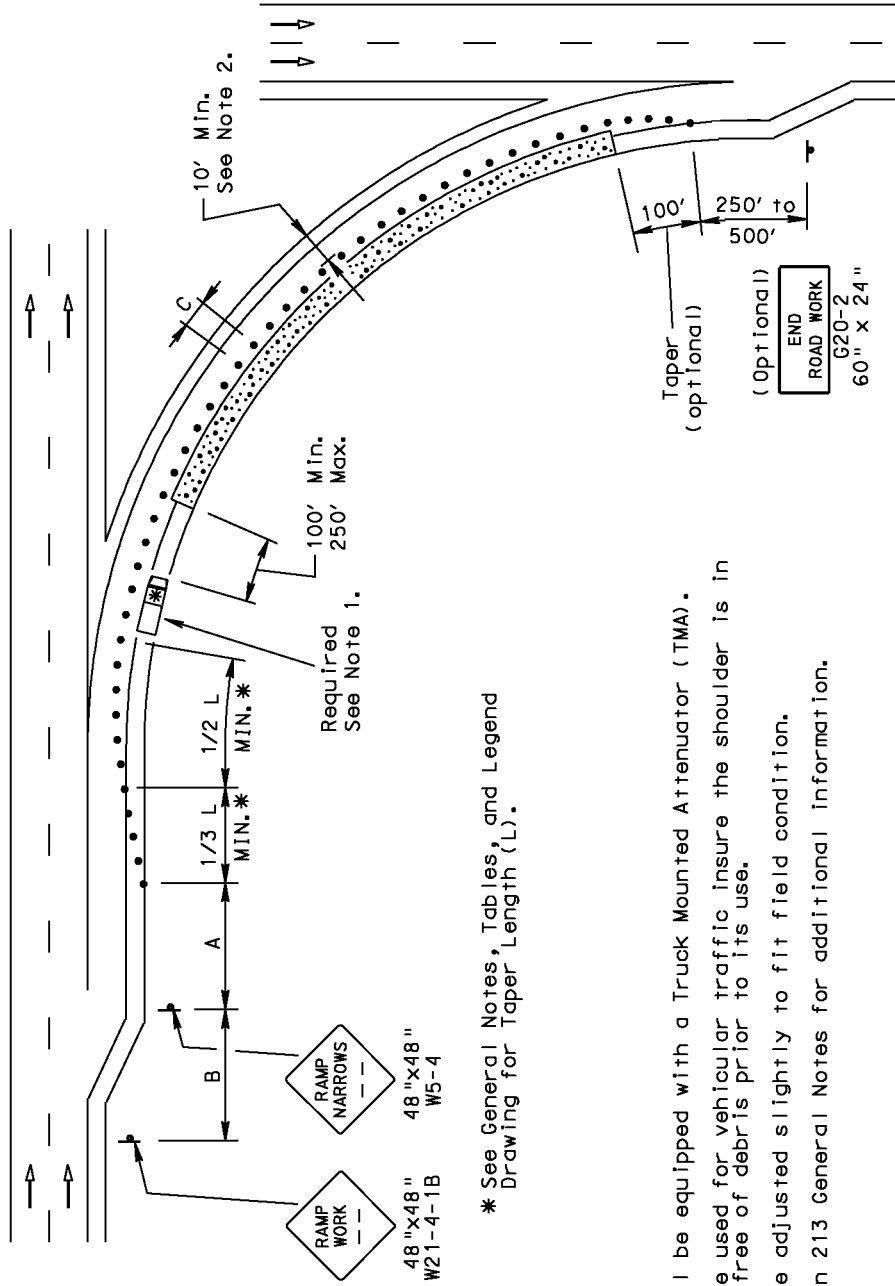

* See General Notes, Tables, and Legend Drawing for Taper Length (L).

NOTES

1. Shadow vehicle shall be equipped with a Truck Mounted Attenuator (TMA).
2. If shoulder is to be used for vehicular traffic insure the shoulder is in good condition and free of debris prior to its use.
3. All distances may be adjusted slightly to fit field condition.
4. Refer to Publication 213 General Notes for additional information.

Distance plaques on Advance Warning signs shall be the same series type.
 Example: either all XXX ft. or all "AHEAD"
 A = 500 ft., W21-4-1B sign distance plaque to read 500 ft. or "AHEAD"
 B = 500 ft., W5-4-2 sign distance plaque to read 1000 ft. or "AHEAD"
 C = 40 ft. MAX.

PUBLICATION 213
 SHORT-TERM STATIONARY OPERATION
 LANE CLOSURE NEAR A FREEWAY OR EXPRESSWAY ENTRANCE RAMP

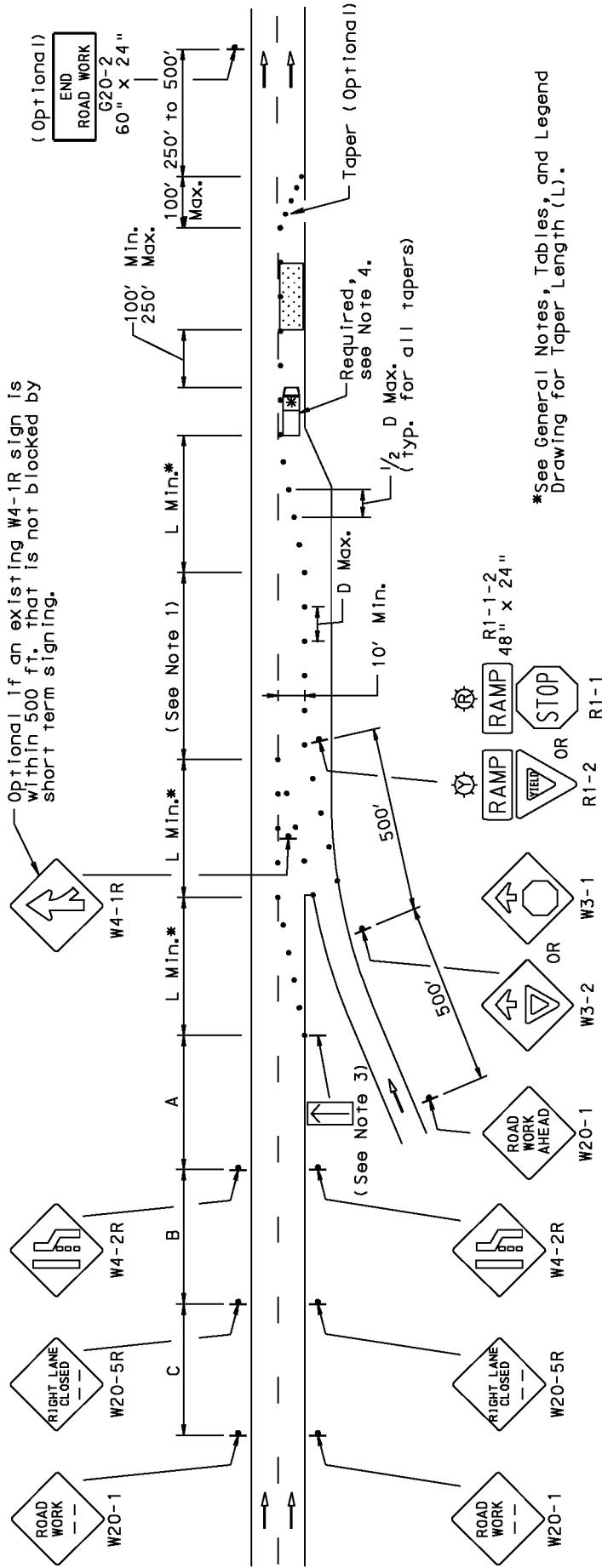

Distance plaques on Advance Warning signs shall be the same series type.
 Example: either all XXX ft. or all "AHEAD"

A = 1000 ft.
 B = 1640 ft., W20-5R sign distance plaque to read 1/2 MILE or "AHEAD"
 C = 2640 ft., W20-1 sign distance plaque to read 1 MILE or "AHEAD"
 D = 2 times the normal speed limit.

- NOTES**
1. An acceleration lane of sufficient length should be provided whenever possible.
 2. Where inadequate acceleration distance exists for the temporary entrance, the Yield (R1-2) and Yield Ahead (W3-2) Signs shall be replaced with Stop (R1-1) and Stop Ahead (W3-1) Signs.
 3. See PATA GENERAL, Table 5 for size of the Flashing Arrow Panel.
 4. Shadow vehicle shall be equipped with a Truck Mounted Attenuator (TMA).
 5. Where speed or volume is higher, signing such as additional Right Lane Closed XX ft Sign (W20-5R) or Be Prepared To Stop Sign (W3-4) should be used in advance of the W20-1 sign.

PATA
 22

PUBLICATION 213
 MOBILE OPERATION - DIVIDED HIGHWAY, ONE-WAY HIGHWAY, ONE-WAY HIGHWAY, CENTER, OR RIGHT LANE
 OR TWO OR MORE LANE APPROACH OF AN UNDIVIDED HIGHWAY - WORK AREA IN THE LEFT, CENTER, OR RIGHT LANE

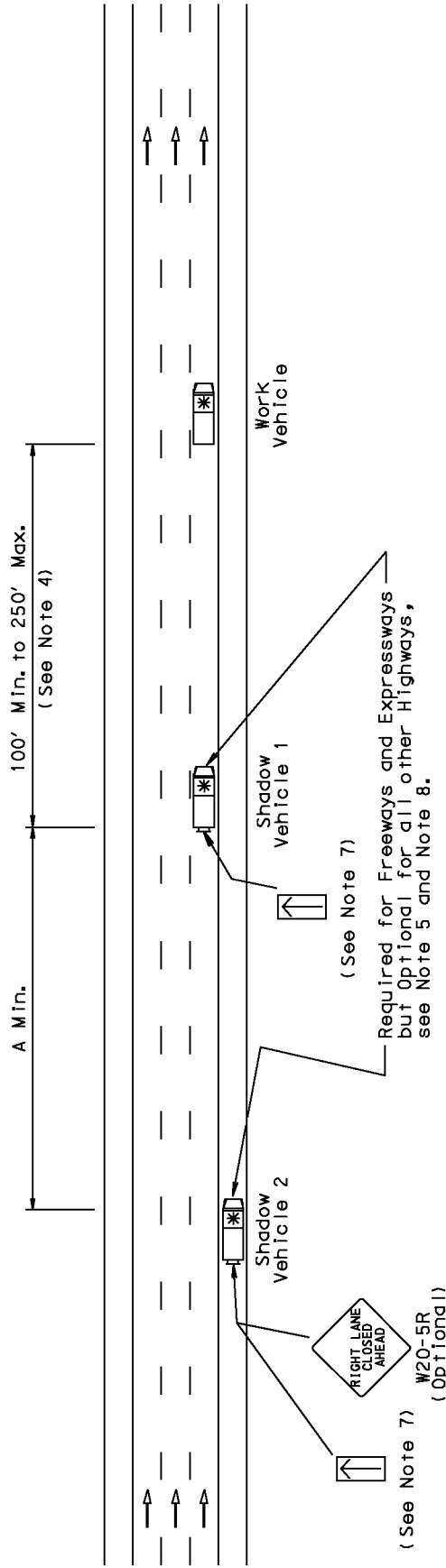

- CONDITION 1: All Highways (except Freeways and Expressways)**
 A Min. = 500 ft.
- CONDITION 2: For Urban Streets**
 A Min. = 200 ft.
- CONDITION 3: For Freeway and Expressway Highways**
 A Min. = 1000 ft.

NOTES

1. This figure applies for operations that move intermittently or continuously at an average speed of more than 1 MPH.
2. When the work vehicle occupies the far left lane or an interior lane, the appropriate lane closure sign should be used in place of the W20-5R Sign on Shadow Vehicle 2. The lane closure sign on Shadow Vehicle 2 should be placed so as not to obscure the arrow panel.
3. When the work vehicle occupies an interior lane (a lane other than the far right or far left) of a directional roadway with a right shoulder 10 ft or more in width, Shadow Vehicle 2 should drive in the right shoulder with a sign indicating that work is taking place in the interior lane.
4. Whenever adequate stopping sight distance exists to the rear, the shadow vehicle should maintain the minimum distance from the work vehicle and proceed at the same speed. The shadow vehicle should slow down in advance of vertical or horizontal curves.
5. Additional shadow vehicles to warn and reduce the speed of oncoming or opposing vehicular traffic may be used. Law enforcement vehicles may be used for this purpose but not to be used to close a lane.
6. Work should normally be accomplished during off-peak hours.
7. See PATA GENERAL, Table 5 for size of the Flashing Arrow Panel.
8. All shadow vehicles shall be equipped with Truck Mounted Attenuator (TMA).

PUBLICATION 213
LONG-TERM STATIONARY OPERATION
ADJACENT TO ANY ROADWAY

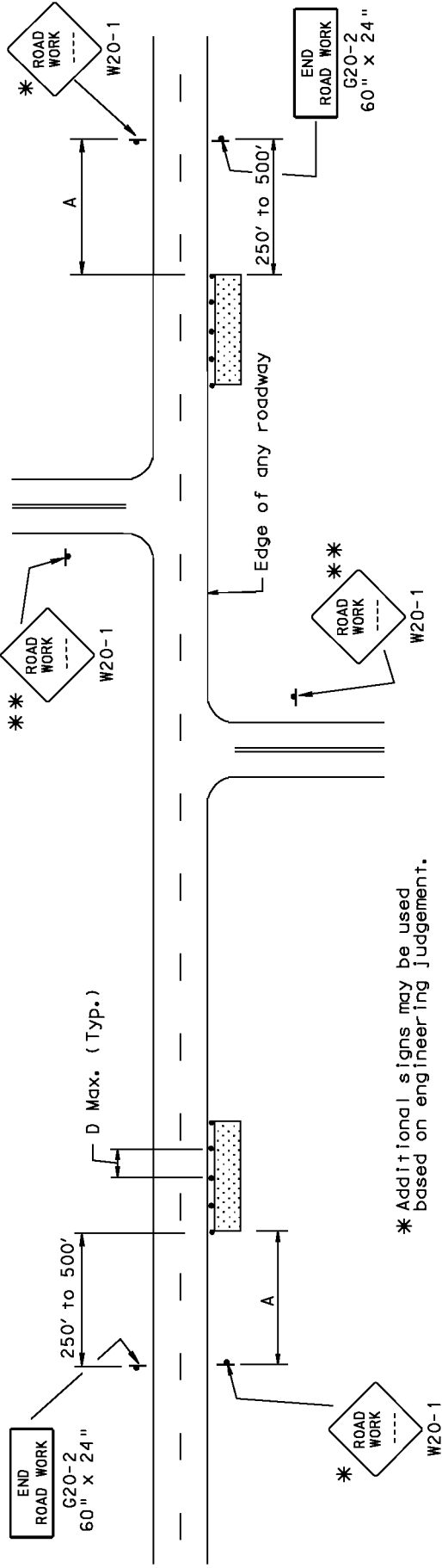

* Additional signs may be used based on engineering judgement.

Distance plaques on Advance Warning signs shall be the same series type.

Example: either all XXX ft. or all "AHEAD"

CONDITION 1: All Highways (except Freeways and Expressways):

A = 500 ft., W20-1 sign distance plaque to read 500 ft. or "AHEAD"

D = 2 times the normal speed limit.

CONDITION 2: For Urban Streets:

A = 200 ft. and sign distance plaque to read "AHEAD"

D = 2 times the normal speed limit

CONDITION 3: For Freeway and Expressway Highways:

A = 1000 ft., W20-1 sign distance plaque to read 1000 ft. or "AHEAD"

D = 2 times the normal speed limit

NOTES

1. Traffic control devices are not required if the work space is outside the highway right-of-way, behind barrier, more than 2 ft behind curb, or 15 ft or more from the edge of any roadway.
2. For divided highways and one-way highways where it is physically possible, advance warning signs should also be placed on the left-hand side of the roadway.
3. The W20-1 Sign may be replaced with other appropriate signs (Low Shoulder Sign, No Guide Rail Sign, and so forth).
4. The W20-1 Sign on an intersecting roadway is not required if drivers emerging from that roadway will encounter another advance warning sign prior to the work space.

PUBLICATION 213
LONG-TERM STATIONARY OPERATION
NUMEROUS NIGHTTIME WORK AREAS ON OR BEYOND THE SHOULDER

*See General Notes, Tables, and Legend
Drawing for Taper Length (L).

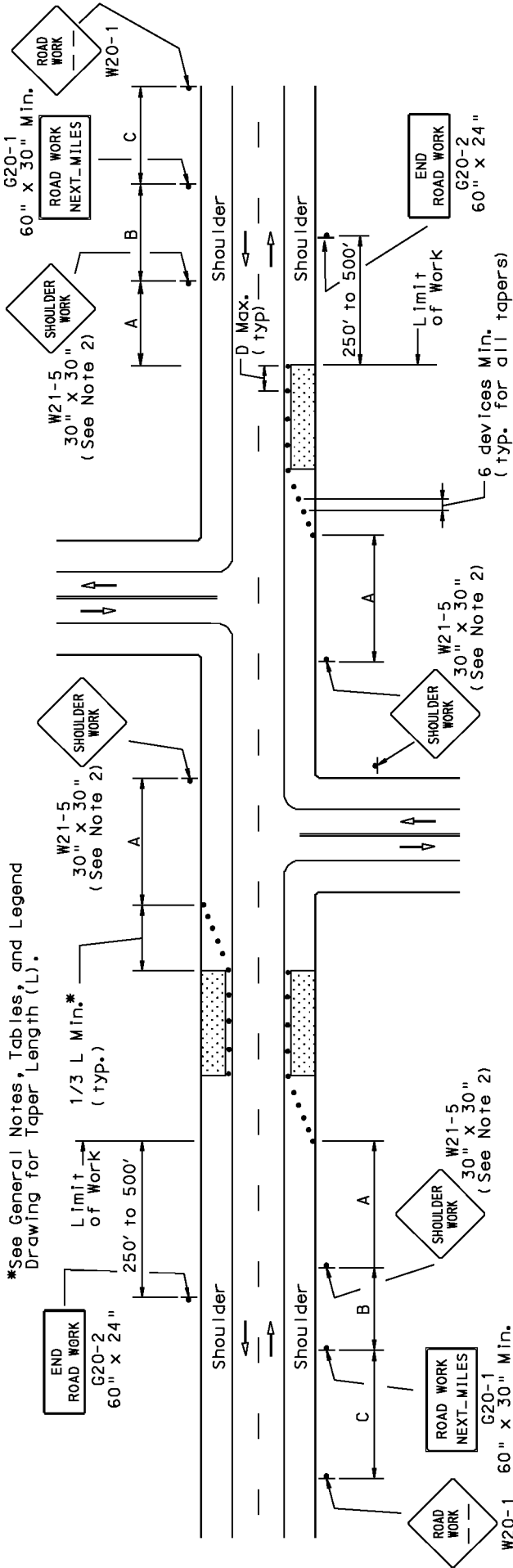

Distance plaques on Advance Warning signs shall be the same series type.

Example: either all XXX ft. or all "AHEAD"

CONDITION 1: All Highways (except Freeways and Expressways)

A = 500 ft.

B = 500 ft.

C = 500 ft., W20-1 sign distance plaque to read 1500 ft.

D = 2 times the normal speed limit.

CONDITION 2: For Urban Streets

A, B and C = 200 ft. and sign distance plaque to read "AHEAD"

D = 2 times the normal speed limit.

CONDITION 3: For Freeway and Expressway Highways

A = 1000 ft.

B = 1640 ft.

C = 2640 ft., W20-1 sign distance plaque to read 1 MILE

D = 2 times the normal speed limit.

NOTES

- For divided highways and one-way highways where it is physically possible, advance warning signs should also be placed on the left-hand side of the roadway.
- The W21-5 Sign may be replaced with other appropriate signs (Low Shoulder Sign, No Guide Rail Sign, and so forth).
- The W21-5 Sign on an intersecting roadway is not required if drivers emerging from that roadway will encounter another advance warning sign prior to the work space.
- A W21-5BL or W21-5BR Sign should be used on limited-access highways where there is no opportunity for disabled vehicles to pull off the roadway.
- If drivers cannot see a pull-off area beyond the closed shoulder, information regarding the length of the shoulder closure should be provided in feet or miles, as appropriate.
- Based on engineering judgement, a temporary barrier with proper delineation and end treatment may be used instead of longitudinal channelizing devices. The channelized taper is still required.

PUBLICATION 213
 LONG-TERM STATIONARY OPERATION
 TWO-LANE, TWO-WAY ROADWAY - FLAGGING

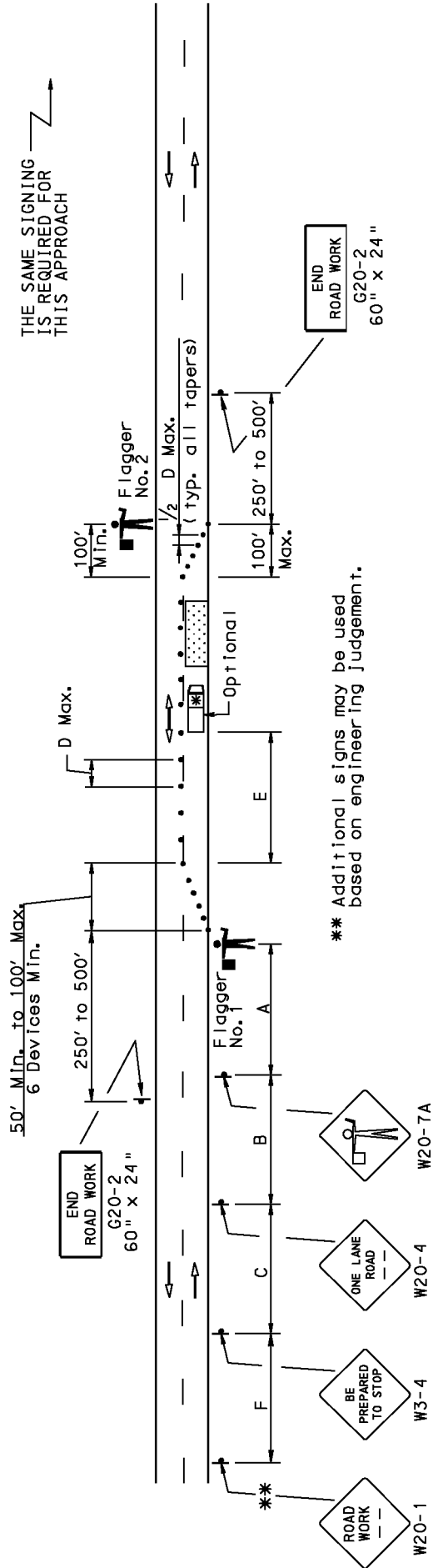

Distance plaques on Advance Warning signs shall be the same series type.

Example: either all XXX ft. or all "AHEAD"

CONDITION 1: All Highways (except Freeways and Expressways)

- A = 500 ft.
- B = 500 ft., W20-4 sign distance plaque to read 1000 ft.
- C = 500 ft., W3-4 sign distance plaque to read 1500 ft.
- F = 500 ft., W20-1 sign distance plaque to read 1/2 MILE.

CONDITION 2: For Urban Streets

A, B, C and F = 200 ft. and sign distance plaque to read "AHEAD"

NOTES

1. All flaggers must be in communication with each other.
2. Each flagger should be clearly visible to traffic for a minimum distance of E.
3. At night, flagger stations shall be illuminated, except in emergencies. See General Notes, sheet 3, note 26.
4. The buffer space should be extended so that the two-way traffic taper is placed before a horizontal (or crest vertical) curve to provide adequate sight distance for the flagger and a queue of stopped vehicles.
5. When a highway-rail grade crossing exists within the work zone, or it is anticipated that queues resulting from the lane closure might extend through a highway-rail grade crossing, provisions shall be made to eliminate conflicts, which may require placing a flagger at the crossing. Coordination with the railroad is essential.

All Highways (except freeway and expressway)	E*	
	D	E*
MPH	ft	ft
25	50	155
30	60	200
35	70	250
40	80	305
45	90	360
50	100	425
55	110	495

*Distances may be increased for downgrades or other conditions that affect stopping sight distance.

PATA
26a

PUBLICATION 213
LONG-TERM STATIONARY OPERATION
TWO-LANE, TWO-WAY ROADWAY - SINGLE FLAGGER

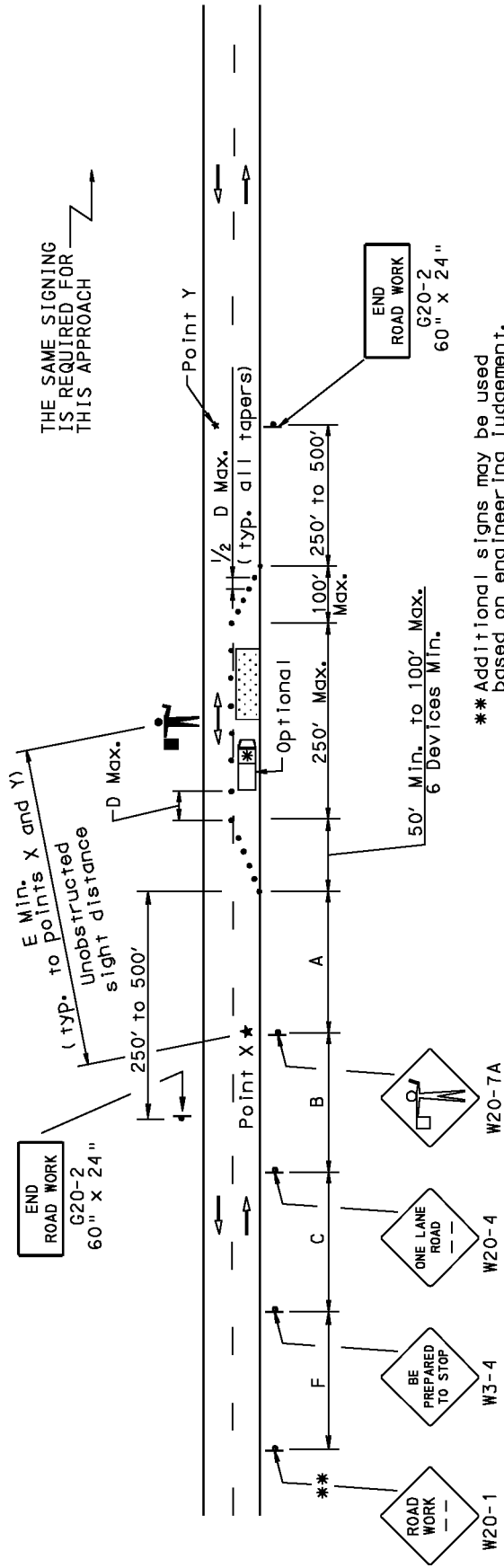

** Additional signs may be used based on engineering judgement.

Distance plaques on Advance Warning signs shall be the same series type.

Example: either all XXX ft. or all "AHEAD"

- CONDITION 1: All Highways (except Freeways and Expressways)
- A = 500 ft.
 - B = 500 ft., W20-4 sign distance plaque to read 1000 ft.
 - C = 500 ft.
 - F = 500 ft., W20-1 sign distance plaque to read 1/2 MILE.
- CONDITION 2: For Urban Streets:
- A, B, C and F = 200 ft. and sign distance plaque to read "AHEAD"
 - (Distance C and the second W3-4 sign may be eliminated)

NOTES

1. This figure applies when all of the following conditions are satisfied:
 - a. Sight distance between the flagger and any vehicle between Points X and Y will be unobstructed.
 - b. The length of the one-lane section (not including any taper) is not greater than approximately 250 ft.
 - c. The ADT is not greater than approximately 1500, or the average 5-minute traffic volume during the period of work is 12 vehicles or less.
 - d. Flagger should be clearly visible to traffic for a minimum distance of E.
2. At night, flagger station shall be illuminated, except in emergencies. See General Notes, sheet 3, note 26.
3. When a highway-rail grade crossing exists within the work zone, or it is anticipated that queues resulting from the lane closure might extend through a highway-rail grade crossing, provisions shall be made to eliminate conflicts, which may require placing a flagger at the crossing. Coordination with the railroad is essential.

All Highways (except freeway and expressway)	D	E *
	ft	ft
MPH	50	155
25	60	200
30	70	250
35	80	305
40	90	360
45		

For speeds greater than 45 MPH, use Figure PATA 26a.

* Distances may be increased for downgrades or other conditions that affect stopping sight distance.

PATA
26b

PUBLICATION 213
 LONG-TERM STATIONARY OPERATION
 TWO-LANE, TWO-WAY ROADWAY - SELF-REGULATING LANE CLOSURE

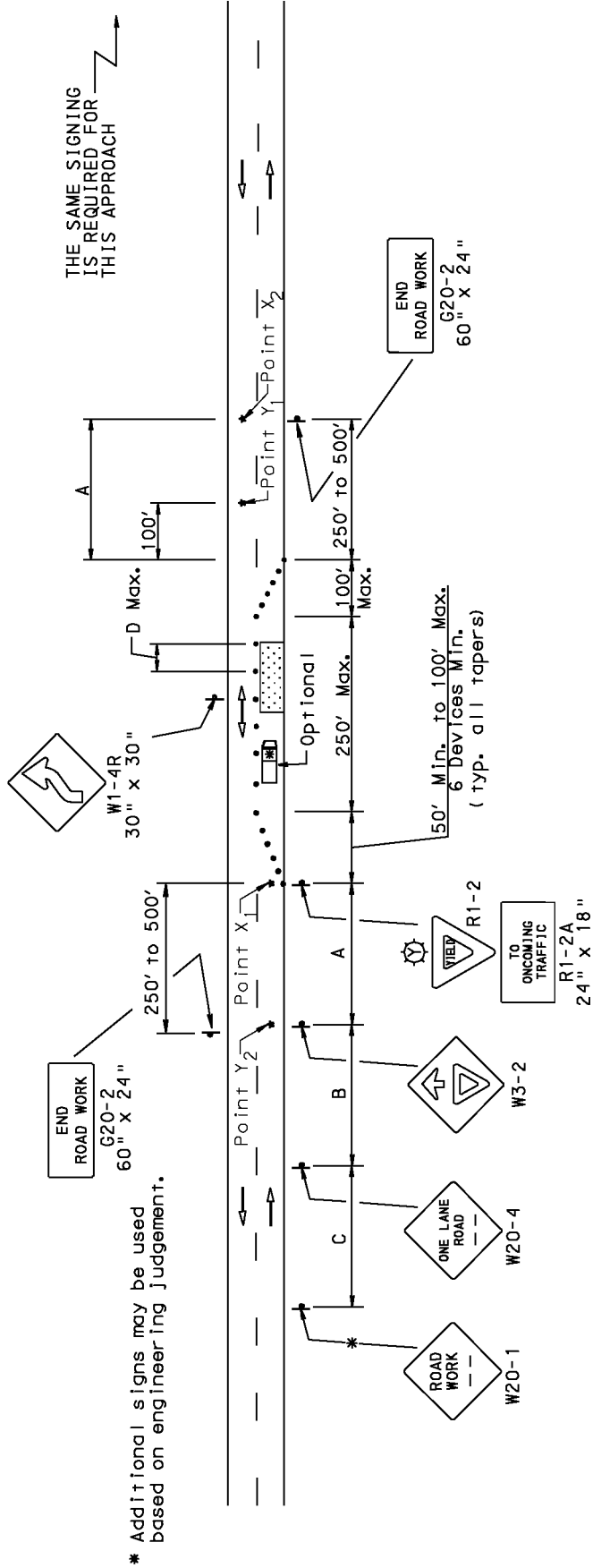

Distance plaques on Advance Warning signs shall be the same series type.

Example: either all XXX ft. or all "AHEAD"

CONDITION 1: All Highways (except Freeways and Expressways)
 A = 500 ft.
 B = 500 ft., W20-4 sign distance plaque to read 1000 ft.
 C = 500 ft., W20-1 sign distance plaque to read 1500 ft.
 D = 2 times the normal speed limit.

CONDITION 2: For Urban Streets:
 A, B, and C = 200 ft. and sign distance plaque to read "AHEAD"
 D = 2 times the normal speed limit.

- NOTES
- This figure applies when all of the following conditions are satisfied:
 - Sight distance between X₁ and X₂, and between Y₁ and Y₂, will be unobstructed.
 - The length of the one-lane section (not including any taper) is not greater than approximately 250 ft.
 - The ADT is not greater than approximately 750.
 - The length of the one-lane section and/or ADT may be increased if a study indicates that a satisfactory level of service can be maintained.
 - When a highway-rail grade crossing exists within the work zone, or it is anticipated that queues resulting from the lane closure might extend through a highway-rail grade crossing, provisions shall be made to eliminate conflicts, which may require placing a flagger at the crossing. Coordination with the railroad is essential.

**BLANK
PAGE**

PUBLICATION 213
TEMPORARY TRAFFIC CONTROL SIGNALS

REFERENCE GUIDE FOR PATA 26e TYPICAL TEMPORARY TRAFFIC CONTROL SIGNAL FIGURES			
TYPE OF HIGHWAY	CONDITION	FIGURE NUMBER	
		USING FIXED SUPPORTS	USING PEDESTAL-MOUNTED PORTABLE TRAFFIC CONTROL SIGNALS
TWO-LANE, TWO WAY HIGHWAY WITH ONE-LANE, TWO-WAY TRAFFIC	SHORT-TERM STATIONARY OPERATION MANUALLY-CONTROLLED	PATA 26e M-1	PATA 26e M-2
	SHORT-TERM STATIONARY OPERATION FOR NON-COMPLEX CONDITIONS	PATA 26e NC-1	PATA 26e NC-2
	SHORT-TERM STATIONARY OPERATION FOR COMPLEX CONDITIONS	PATA 26e C-1	PATA 26e C-2
	LONG-TERM STATIONARY OPERATION	PATA 26e L	PATA 26e PL

APPENDIX A INDEX; TEMPORARY TRAFFIC CONTROL SIGNAL DOCUMENTATION

DOCUMENT TYPE
TEMPORARY TRAFFIC CONTROL SIGNAL REQUIREMENTS AND TIMEFRAMES
PROCESS FOR OBTAINING PENNDOT APPROVAL TO USE TEMPORARY TRAFFIC CONTROL SIGNALS
BLANKET PERMITS
APPLICATION FOR PERMIT TO OPERATE TEMPORARY TRAFFIC CONTROL SIGNALS
TEMPORARY TRAFFIC CONTROL SIGNAL PERMIT
APPLICATION INSTRUCTIONS FOR PERMIT TO OPERATE TEMPORARY TRAFFIC CONTROL SIGNALS
EXAMPLE PROBLEM: APPLICATION FOR PERMIT TO OPERATE TEMPORARY TRAFFIC CONTROL SIGNALS
GUIDELINES FOR THE SELECTION OF TEMPORARY TRAFFIC CONTROL SIGNALS IN WORK ZONES
TEMPORARY TRAFFIC CONTROL SIGNALS NON-COMPLIANCE DOCUMENTATION FORM
TEMPORARY TRAFFIC CONTROL SIGNALS USER COMMENT FORM

PUBLICATION 213
 SHORT-TERM STATIONARY OPERATION - TWO-LANE, TWO-WAY ROADWAY
 TEMPORARY TRAFFIC CONTROL SIGNALS - MANUALLY-CONTROLLED, PEDESTAL-MOUNTED PORTABLE TRAFFIC CONTROL SIGNALS

Dist.	County	Route	Sheet
			1 of 4

TEMPORARY TRAFFIC CONTROL SIGNAL PLAN

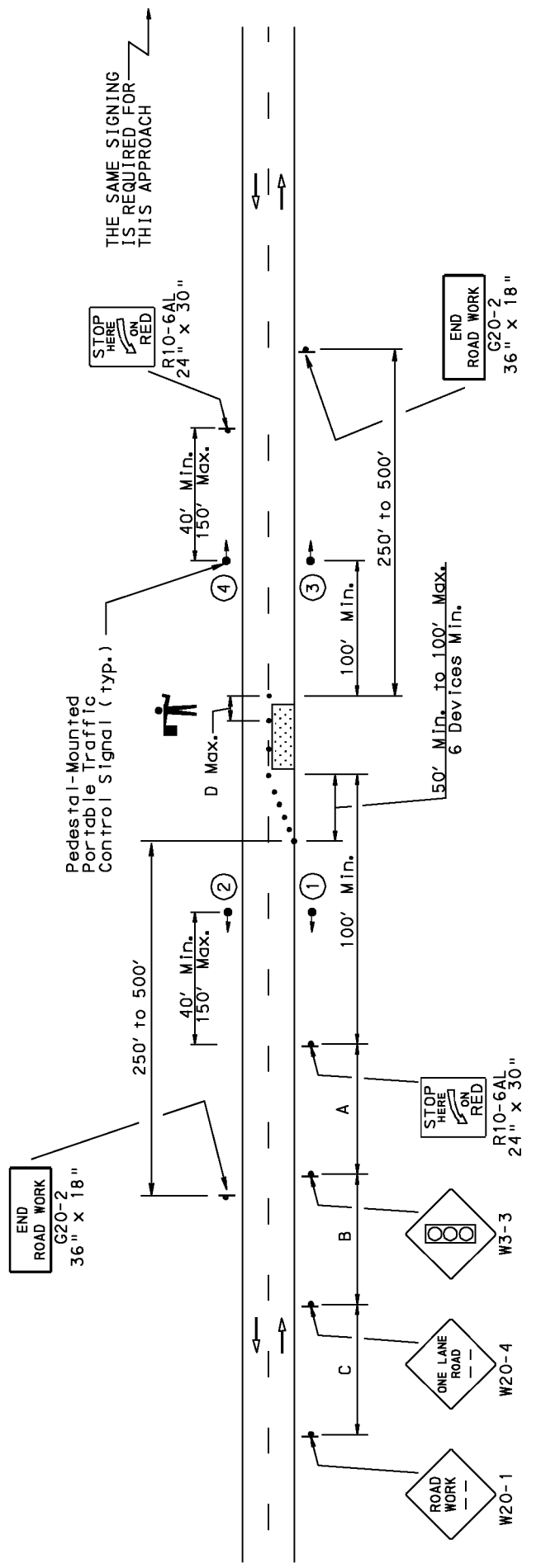

Distance plaques on Advance Warning signs shall be the same series type.

Example: either all XXX ft. or all "AHEAD"

- CONDITION 1: All Highways (except Freeways and Expressways)
- A = 500 ft.
 - B = 500 ft., W20-4 sign distance plaque to read 1000 ft.
 - C = 500 ft., W20-1 sign distance plaque to read 1500 ft.
 - D = 2 times the normal speed limit

- CONDITION 2: For Urban Streets
- A, B and C = 200 ft. and sign distance plaque to read "AHEAD"
 - D = 2 times the normal speed limit

PERMIT NO.: _____

PERMITTEE: _____

PENNDOT APPROVAL: _____

DIST. TRAF. ENGINEER

DATE: _____

PATA
26e M-1

PUBLICATION 213
 SHORT-TERM STATIONARY OPERATION - TWO-LANE, TWO-WAY ROADWAY
 TEMPORARY TRAFFIC CONTROL SIGNALS - MANUALLY-CONTROLLED, PEDESTAL-MOUNTED PORTABLE TRAFFIC CONTROL SIGNALS

Dist.	County	Route	Sheet
			2 of 4

SIGNAL	Phase 1			Phase 2			EMERGENCY FLASHING
	1	2	3	1	2	3	
①	G	Y	R	R	R	R	R
②	R	R	R	G	Y	R	R
③							
④							
⑤							
⑥							
⑦							
⑧							
⑨							
⑩							
⑪							
⑫							
⑬							
⑭							
⑮							
⑯							
⑰							
⑱							
⑲							
⑳							
㉑							
㉒							
㉓							
㉔							
㉕							
㉖							
㉗							
㉘							
㉙							
㉚							
㉛							
㉜							
㉝							
㉞							
㉟							
㊱							
㊲							
㊳							
㊴							
㊵							
㊶							
㊷							
㊸							
㊹							
㊺							
㊻							
㊼							
㊽							
㊾							
㊿							

ANY FIELD ADJUSTMENT OF "STOP HERE ON RED SIGNS" REQUIRES NEW CALCULATION OF CLEARANCE INTERVALS IN ACCORDANCE WITH PENNDOT SPECIFICATIONS.

- * SEE TABLE AND NOTE 14.
- ▲ INTERVAL DETERMINED BY OPERATOR.

SIGNAL REQUIREMENTS

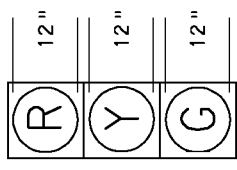

SIGNAL NO'S.
1-2-3-4

NOTE:
ALL SIGNALS TO BE EQUIPPED WITH BACKPLATES.

All-Red Clearance Interval Calculations (See Note 14)

Length of One-Lane, Two-Way Traffic Section between STOP HERE ON RED SIGNS (FT)	Required Minimum Length of All-Red Clearance Interval (SEC)		
	15 MPH	20 MPH	25 MPH
1,000	45	34	27
950	43	32	26
900	41	31	25
850	39	29	23
800	36	27	22
750	34	26	20
700	32	24	19
650	30	22	18
600	27	20	16
550	25	19	15
500	23	17	14
450	20	15	12
400	18	14	11
350	16	12	10
300	14	10	8

Signal Face Visibility (See Note 12)	
Normal Speed Limit (MPH)	Minimum Visibility Distance (FT)
25	215
30	270
35	325
40	390
45	460
50	540
55	625

PERMIT NO.: _____

PERMITTEE: _____

PENNDOT APPROVAL: _____

DIST. TRAF. ENGINEER _____

DATE: _____

PUBLICATION 213
SHORT-TERM STATIONARY OPERATION - TWO-LANE, TWO-WAY ROADWAY TRAFFIC CONTROL SIGNALS

Dist.	County	Route	Sheet
			3 of 4

NOTES

1. THE USE OF MANUALLY-CONTROLLED, PEDESTAL-MOUNTED PORTABLE TRAFFIC CONTROL SIGNALS IN PENNSYLVANIA FOR SHORT-TERM STATIONARY OPERATIONS SHALL COMPLY WITH PROVISIONS OF THIS FIGURE.
2. THIS FIGURE MAY BE USED IF ALL OF THE FOLLOWING CONDITIONS ARE SATISFIED:
 - a. THE OPERATION IS A STATIONARY, SHORT-TERM OPERATION AS DEFINED IN PENNDOT PUBLICATIONS 212 AND 213.
 - b. THE PORTABLE TRAFFIC CONTROL SIGNALS ARE USED TO CONTROL ONE-LANE, TWO-WAY TRAFFIC, AND NO MORE THAN TWO APPROACHES TO THE WORK ZONE WILL BE CONTROLLED BY THE PORTABLE TRAFFIC CONTROL SIGNALS.
 - c. THERE IS NO AT-GRADE RAILROAD CROSSING WITHIN THE ONE-LANE, TWO-WAY TRAFFIC SECTION (BETWEEN STOP HERE ON RED SIGNS) AND WITHIN 300 FEET OF A PORTABLE TRAFFIC CONTROL SIGNAL.
 - d. NO ROADWAY APPROACH TO THE PORTABLE TRAFFIC CONTROL SIGNAL IS ON A DOWNGRADE OF 5% OR MORE, IF THE NORMAL SPEED LIMIT IS GREATER THAN 35 MILES PER HOUR.
 - e. THERE ARE NO INTERSECTIONS OR UNCONTROLLED COMMERCIAL DRIVEWAYS WITHIN THE ONE-LANE, TWO-WAY TRAFFIC SECTION. THE PROPOSED METHOD OF TRAFFIC CONTROL FOR NON-COMMERCIAL DRIVEWAYS SHALL BE ACCEPTABLE TO PENNDOT.
3. FOR MANUAL CONTROL, A SINGLE OPERATOR MAY BE USED IF THE OPERATOR HAS AN UNOBSTRUCTED VIEW OF BOTH TRAFFIC TRAVELING THROUGH THE ONE-LANE, TWO-WAY SECTION AND TRAFFIC ON THE APPROACH TO EACH PORTABLE TRAFFIC CONTROL SIGNAL UNIT. OTHERWISE, A SEPARATE OPERATOR IS REQUIRED AT EACH PORTABLE TRAFFIC CONTROL SIGNAL UNIT AND COMMUNICATIONS MUST BE MAINTAINED BETWEEN THE OPERATORS.
4. SUPPLEMENTAL SIGNAL INDICATOR LAMPS ARE REQUIRED TO SHOW THE OPERATOR THE STATUS OF THE SIGNAL INDICATIONS IF THE CONTROLLER DOES NOT PROVIDE A VISUAL DISPLAY OF THE SIGNAL INDICATIONS.
5. PORTABLE TRAFFIC CONTROL SIGNAL OPERATIONS SHOULD REMAIN IN A MANUALLY-CONTROLLED MODE AND SHOULD NOT BE CHANGED UNLESS DIRECTED BY PENNDOT.
6. ADVANCE WRITTEN APPROVAL MUST BE OBTAINED FROM PENNDOT PRIOR TO USING PORTABLE TRAFFIC CONTROL SIGNALS FOR SHORT-TERM OPERATIONS ON ANY PUBLIC HIGHWAY. A PENNDOT TEMPORARY TRAFFIC CONTROL SIGNAL PERMIT IS REQUIRED FOR SHORT-TERM OPERATIONS, AND A COPY MUST BE MAINTAINED ON-SITE DURING THE PERIOD OF PORTABLE TRAFFIC CONTROL SIGNAL USAGE.
7. SUBMIT A COMPLETED APPLICATION FOR A PERMIT TO OPERATE TEMPORARY TRAFFIC CONTROL SIGNALS TO THE APPROPRIATE PENNDOT ENGINEERING DISTRICT OFFICE SO THAT IT IS RECEIVED AT LEAST 3 FULL WORKING DAYS BEFORE THE DESIRED BEGINNING TIME OF THE PORTABLE TRAFFIC CONTROL SIGNAL USAGE, EXCEPT FOR EMERGENCY WORK AS DEFINED IN PENNDOT PUBLICATION 212.
8. REFER TO APPENDIX A OF THIS PUBLICATION FOR ADDITIONAL GUIDANCE AND ACCEPTANCE PROCEDURES PERTAINING TO PORTABLE TRAFFIC CONTROL SIGNALS.
9. THE DESIGN AND APPLICATION OF THE PORTABLE TRAFFIC CONTROL SIGNALS SHALL COMPLY WITH THE MOST CURRENT VERSION OF PENNDOT PUBLICATIONS 212, 213, AND 149.
10. SIGNAL SUPPORTS SHOULD BE A MINIMUM OF 2 FEET OFF THE EDGE OF TRAVEL WAY. IF THIS IS NOT POSSIBLE, THE SUPPORTS SHALL BE ADEQUATELY PROTECTED BY BARRIER, GUIDERAIL, OR CHANNELIZING DEVICES.
11. THE BOTTOM OF THE HOUSING OF A SIGNAL FACE THAT IS NOT MOUNTED OVER THE ROADWAY SHALL BE AT LEAST 8 FEET, BUT NOT MORE THAN 15 FEET ABOVE THE SIDEWALK OR, IF THERE IS NO SIDEWALK, ABOVE THE PAVEMENT GRADE AT THE CENTER OF THE ROADWAY.
12. A MINIMUM OF TWO SIGNAL FACES ON EACH APPROACH SHOULD BE CONTINUOUSLY VISIBLE TO APPROACHING TRAFFIC FROM A POINT MEETING THE SIGNAL VISIBILITY DISTANCES SPECIFIED IN THE TABLE ON SHEET 2 OF 3.

(NOTES CONT'D. ON SHEET 4)

PERMIT NO.:	
PERMITTEE:	
PENNDOT APPROVAL:	DIST. TRAF. ENGINEER
DATE:	

PUBLICATION 213
 SHORT-TERM STATIONARY OPERATION - TWO-LANE, TWO-WAY ROADWAY
 TEMPORARY TRAFFIC CONTROL SIGNALS - MANUALLY-CONTROLLED, PEDESTAL-MOUNTED PORTABLE TRAFFIC CONTROL SIGNALS

Dist.	County	Route	Sheet
			4 of 4

NOTES

(CONT' D. FROM SHEET 3)

13. THE LENGTH OF YELLOW CHANGE INTERVALS IS NORMALLY IN THE RANGE FROM ABOUT 3 SECONDS TO 6 SECONDS. USE A 5-SECOND YELLOW CHANGE INTERVAL, OR AN APPROPRIATE ALTERNATE VALUE FROM PENNDOT PUBLICATION 149 BASED ON ACTUAL SITE CONDITIONS.
14. AN ALL-RED CLEARANCE INTERVAL MUST BE USED. THE LENGTH OF THE ALL-RED CLEARANCE INTERVAL IS BASED ON THE LENGTH OF THE ONE-LANE, TWO-WAY TRAFFIC SECTION CONTROLLED BY THE PORTABLE TRAFFIC CONTROL SIGNALS AND THE SPEED OF TRAFFIC THROUGH THAT SECTION. MONITOR TRAFFIC OPERATIONS DURING THE PERIOD OF PORTABLE TRAFFIC CONTROL SIGNAL USAGE AND ADJUST THE LENGTH OF THE ALL-RED CLEARANCE INTERVAL TO ACCOUNT FOR SITE CONDITIONS AND TO PROVIDE FOR SAFE AND EFFICIENT TRAFFIC OPERATIONS. UNLESS OTHERWISE INDICATED BY PENNDOT, THE MINIMUM LENGTH OF ALL-RED CLEARANCE INTERVALS SHALL BE AS INDICATED ON THE TABLE ON SHEET 2 OF 4.
15. WHEN NOT IN OPERATION, SIGNAL HEADS SHALL BE REMOVED FROM THE VIEW OF TRAFFIC OR HOODED WITH A MATERIAL THAT COVERS THE SIGNAL INDICATIONS FROM THE VIEW OF TRAFFIC. ALL INAPPROPRIATE SIGNS SHALL ALSO BE REMOVED, COVERED, FOLDED, OR TURNED SO THAT THEY ARE NOT READABLE BY ONCOMING TRAFFIC WHEN THE PORTABLE TRAFFIC CONTROL SIGNAL IS NOT IN OPERATION.
16. SIGNAL MODULES MUST BE REPLACED IN ACCORDANCE WITH THE MANUFACTURERS RECOMMENDATIONS, AND A RECORD OF THIS MUST BE MAINTAINED BY THE USER.
17. ADDITIONAL SIGNS AND DEVICES SHALL BE INSTALLED AS REQUIRED IN PENNDOT PUBLICATIONS 212 AND 213, AND AS REQUIRED BASED ON ACTUAL SITE CONDITIONS.
18. PENNDOT RESERVES THE RIGHT TO INSPECT EACH PORTABLE TRAFFIC CONTROL SIGNAL USAGE. PENNDOT ALSO RESERVES THE RIGHT TO REVOKE A TEMPORARY TRAFFIC CONTROL SIGNAL PERMIT OR TO SUSPEND THE OPERATION OF THE PORTABLE TRAFFIC CONTROL SIGNAL IF THE USER SHALL AT ANY TIME WILLFULLY OR NEGLIGENTLY FAIL TO COMPLY WITH THE CONDITIONS CONTAINED IN THE PERMIT OR PUBLICATION 213, OR FAIL TO MAKE ANY CHANGES IN THE OPERATION OF THE SIGNAL, OR REMOVE IT, WHEN SO ORDERED BY PENNDOT. THE USER SHALL NOT MAKE ANY CHANGE IN THE OPERATION OF THE PORTABLE TRAFFIC CONTROL SIGNAL AS DEFINED IN THE PERMIT DRAWINGS WITHOUT PRIOR WRITTEN APPROVAL OF PENNDOT.

PERMIT NO.:	
PERMITTEE:	
PENNDOT APPROVAL:	DIST. TRAF. ENGINEER
DATE:	

PUBLICATION 213
 SHORT-TERM STATIONARY OPERATION - TWO-LANE, TWO-WAY ROADWAY
 TEMPORARY TRAFFIC CONTROL SIGNALS - MANUALLY-CONTROLLED, TRAILER-MOUNTED PORTABLE TRAFFIC CONTROL SIGNALS

Dist.	County	Route	Sheet
			1 of 5

TEMPORARY TRAFFIC CONTROL SIGNAL PLAN

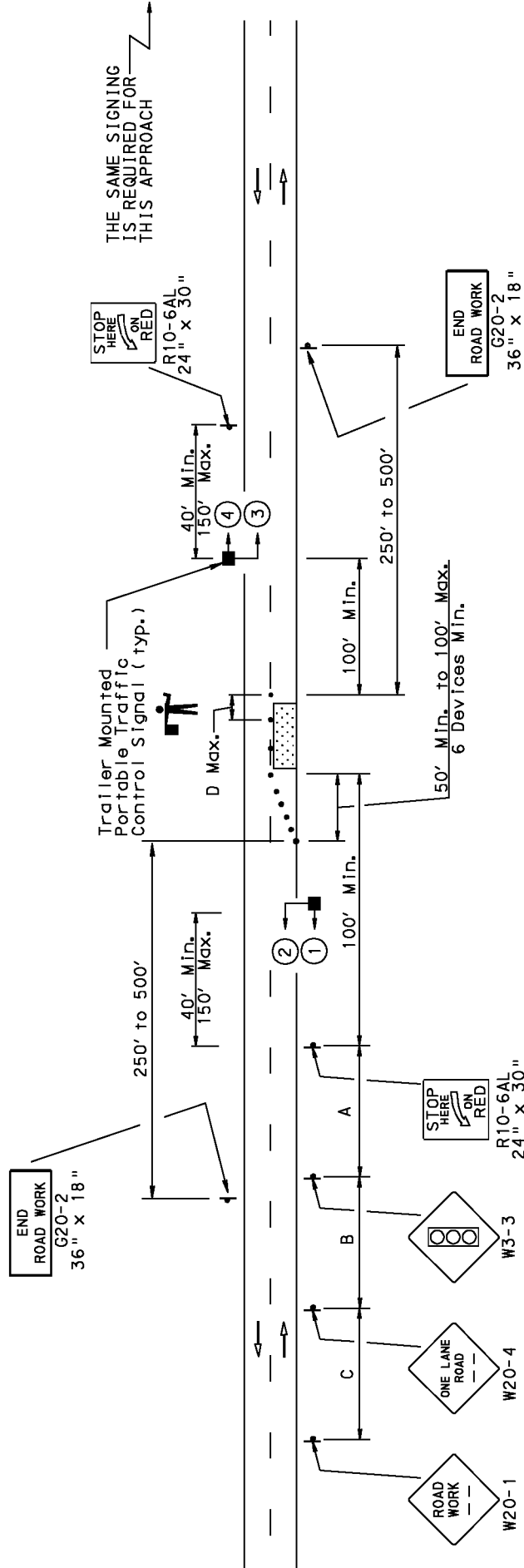

NOTE

Refer to Sheet 3 of 5 for Alternate Trailer-Mounted Portable Traffic Signal Placement.

Distance plaques on Advance Warning signs shall be the same series type.

Example: either all XXX ft. or all "AHEAD"

CONDITION 1: All Highways (except Freeways and Expressways)

A = 500 ft.

B = 500 ft., W20-4 sign distance plaque to read 1000 ft.

C = 500 ft., W20-1 sign distance plaque to read 1500 ft.

D = 2 times the normal speed limit

CONDITION 2: For Urban Streets

A, B and C = 200 ft. and sign distance plaque to read "AHEAD"

D = 2 times the normal speed limit

PERMIT NO.:

PERMITTEE:

PENNDOT APPROVAL:

DIST. TRAF. ENGINEER

DATE:

PATA
 26e M-2

Dist.	County	Route	Sheet 3 of 5
-------	--------	-------	-----------------

ALTERNATE TRAILER-MOUNTED PORTABLE TRAFFIC SIGNAL PLACEMENTS

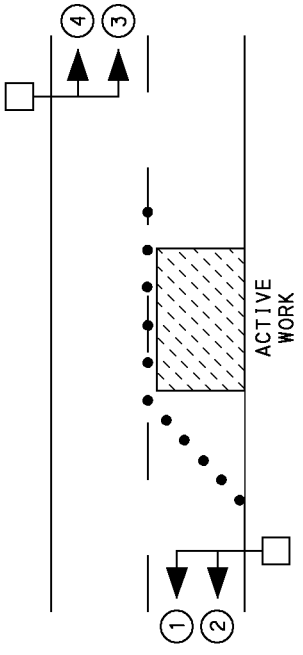

OPTION 1

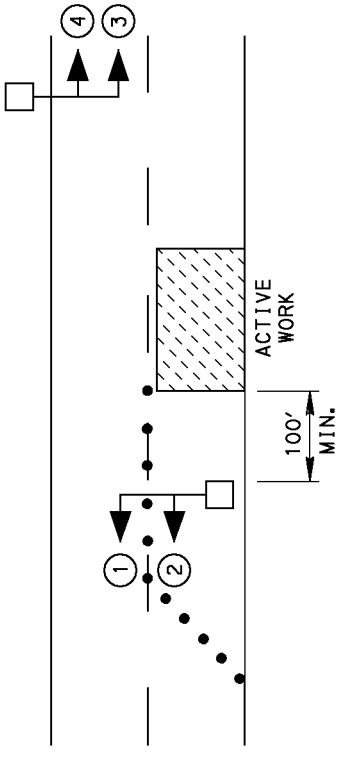

OPTION 2

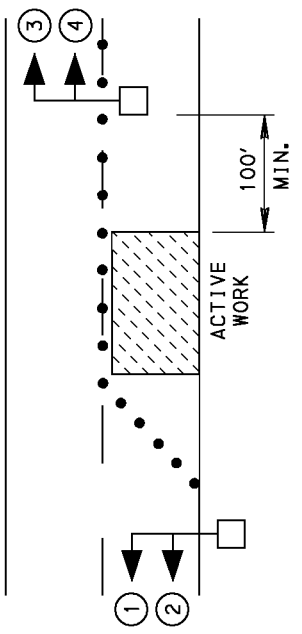

OPTION 3

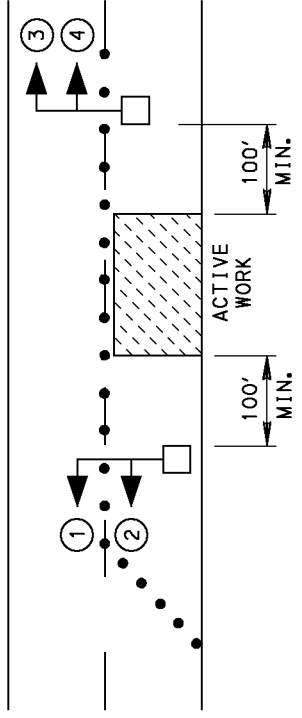

OPTION 4

PERMIT NO.:	_____
PERMITTEE:	_____
PENNDOT APPROVAL:	_____
DATE:	_____
DIST. TRAF. ENGINEER	

PATA
26e M-2

PUBLICATION 213
SHORT-TERM STATIONARY OPERATION - TWO-LANE, TWO-WAY ROADWAY
TEMPORARY TRAFFIC CONTROL SIGNALS - MANUALLY-CONTROLLED, TRAILER-MOUNTED PORTABLE TRAFFIC CONTROL SIGNALS

Dist.	County	Route	Sheet
			4 of 5

NOTES

1. THE USE OF MANUALLY-CONTROLLED, TRAILER-MOUNTED PORTABLE TRAFFIC CONTROL SIGNALS IN PENNSYLVANIA FOR SHORT-TERM STATIONARY OPERATIONS SHALL COMPLY WITH PROVISIONS OF THIS FIGURE.
2. THIS FIGURE MAY BE USED IF ALL OF THE FOLLOWING CONDITIONS ARE SATISFIED:
 - c. THE OPERATION IS A STATIONARY, SHORT-TERM OPERATION AS DEFINED IN PENNDOT PUBLICATIONS 212 AND 213.
 - d. THE PORTABLE TRAFFIC CONTROL SIGNALS ARE USED TO CONTROL ONE-LANE, TWO-WAY TRAFFIC, AND NO MORE THAN TWO APPROACHES TO THE WORK ZONE WILL BE CONTROLLED BY THE PORTABLE TRAFFIC CONTROL SIGNALS.
 - e. THERE IS NO AT-GRADE RAILROAD CROSSING WITHIN THE ONE-LANE, TWO-WAY TRAFFIC SECTION (BETWEEN STOP HERE ON RED SIGNS) AND WITHIN 300 FEET OF A PORTABLE TRAFFIC CONTROL SIGNAL.
 - f. NO ROADWAY APPROACH TO THE PORTABLE TRAFFIC CONTROL SIGNAL IS ON A DOWNGRADE OF 5% OR MORE, IF THE NORMAL SPEED LIMIT IS GREATER THAN 35 MILES PER HOUR.
 - g. THERE ARE NO INTERSECTIONS OR UNCONTROLLED COMMERCIAL DRIVEWAYS WITHIN THE ONE-LANE, TWO-WAY TRAFFIC SECTION. THE PROPOSED METHOD OF TRAFFIC CONTROL FOR NON-COMMERCIAL DRIVEWAYS SHALL BE ACCEPTABLE TO PENNDOT.
3. FOR MANUAL CONTROL, A SINGLE OPERATOR MAY BE USED IF THE OPERATOR HAS AN UNOBSTRUCTED VIEW OF BOTH TRAFFIC TRAVELING THROUGH THE ONE-LANE, TWO-WAY SECTION AND TRAFFIC ON THE APPROACH TO EACH PORTABLE TRAFFIC CONTROL SIGNAL UNIT. OTHERWISE, A SEPARATE OPERATOR IS REQUIRED AT EACH PORTABLE TRAFFIC CONTROL SIGNAL UNIT AND COMMUNICATIONS MUST BE MAINTAINED BETWEEN THE OPERATORS.
4. SUPPLEMENTAL SIGNAL INDICATOR LAMPS ARE REQUIRED TO SHOW THE OPERATOR THE STATUS OF THE SIGNAL INDICATIONS IF THE CONTROLLER DOES NOT PROVIDE A VISUAL DISPLAY OF THE SIGNAL INDICATIONS.
5. PORTABLE TRAFFIC CONTROL SIGNAL OPERATIONS SHOULD REMAIN IN A MANUALLY-CONTROLLED MODE AND SHOULD NOT BE CHANGED UNLESS DIRECTED BY PENNDOT.
6. ADVANCE WRITTEN APPROVAL MUST BE OBTAINED FROM PENNDOT PRIOR TO USING PORTABLE TRAFFIC CONTROL SIGNALS FOR SHORT-TERM OPERATIONS ON ANY PUBLIC HIGHWAY. A PENNDOT TEMPORARY TRAFFIC CONTROL SIGNAL PERMIT IS REQUIRED FOR SHORT-TERM OPERATIONS, AND A COPY MUST BE MAINTAINED ON-SITE DURING THE PERIOD OF PORTABLE TRAFFIC CONTROL SIGNAL USAGE.
7. SUBMIT A COMPLETED APPLICATION FOR A PERMIT TO OPERATE TEMPORARY TRAFFIC CONTROL SIGNALS TO THE APPROPRIATE PENNDOT ENGINEERING DISTRICT OFFICE SO THAT IT IS RECEIVED AT LEAST 3 FULL WORKING DAYS BEFORE THE DESIRED BEGINNING TIME OF THE PORTABLE TRAFFIC CONTROL SIGNAL USAGE, EXCEPT FOR EMERGENCY WORK AS DEFINED IN PENNDOT PUBLICATION 212.
8. REFER TO APPENDIX A OF THIS PUBLICATION FOR ADDITIONAL GUIDANCE AND ACCEPTANCE PROCEDURES PERTAINING TO PORTABLE TRAFFIC CONTROL SIGNALS.
9. THE DESIGN AND APPLICATION OF THE PORTABLE TRAFFIC CONTROL SIGNALS SHALL COMPLY WITH THE MOST CURRENT VERSION OF PENNDOT PUBLICATIONS 212, 213, AND 149.
10. SIGNAL SUPPORTS SHOULD BE A MINIMUM OF 2 FEET OFF THE EDGE OF TRAVEL WAY. IF THIS IS NOT POSSIBLE, THE SUPPORTS SHALL BE ADEQUATELY PROTECTED BY BARRIER, GUIDERAIL, OR CHANNELIZING DEVICES.
11. THE BOTTOM OF THE HOUSING OF A SIGNAL FACE SUSPENDED OVER THE ROADWAY SHALL BE A MINIMUM OF 15 FEET, BUT NOT MORE THAN 19 FEET ABOVE THE PAVEMENT. THE BOTTOM OF THE HOUSING OF A SIGNAL FACE THAT IS NOT MOUNTED OVER THE ROADWAY SHALL BE AT LEAST 8 FEET, BUT NOT MORE THAN 15 FEET ABOVE THE SIDEWALK OR, IF THERE IS NO SIDEWALK, ABOVE THE PAVEMENT GRADE AT THE CENTER OF THE ROADWAY.

(NOTES CONT'D. ON SHEET 4)

PERMIT NO.:	
PERMITTEE:	
PENNDOT APPROVAL:	DIST. TRAF. ENGINEER
DATE:	

PUBLICATION 213
 SHORT-TERM STATIONARY OPERATION - TWO-LANE, TWO-WAY ROADWAY
 TEMPORARY TRAFFIC CONTROL SIGNALS - MANUALLY-CONTROLLED, TRAILER-MOUNTED PORTABLE TRAFFIC CONTROL SIGNALS

Dist.	County	Route	Sheet
			5 of 5

NOTES

(CONT'D. FROM SHEET 3)

12. A MINIMUM OF TWO SIGNAL FACES ON EACH APPROACH SHOULD BE CONTINUOUSLY VISIBLE TO APPROACHING TRAFFIC FROM A POINT MEETING THE SIGNAL VISIBILITY DISTANCES SPECIFIED IN THE TABLE ON SHEET 2 OF 3.
13. THE LENGTH OF YELLOW CHANGE INTERVALS IS NORMALLY IN THE RANGE FROM ABOUT 3 SECONDS TO 6 SECONDS. USE A 5-SECOND YELLOW CHANGE INTERVAL, OR AN APPROPRIATE ALTERNATE VALUE FROM PENNDOT PUBLICATION 149 BASED ON ACTUAL SITE CONDITIONS.
14. AN ALL-RED CLEARANCE INTERVAL MUST BE USED. THE LENGTH OF THE ALL-RED CLEARANCE INTERVAL IS BASED ON THE LENGTH OF THE ONE-LANE, TWO-WAY TRAFFIC SECTION CONTROLLED BY THE PORTABLE TRAFFIC CONTROL SIGNALS AND THE SPEED OF TRAFFIC THROUGH THAT SECTION. MONITOR TRAFFIC OPERATIONS DURING THE PERIOD OF PORTABLE TRAFFIC CONTROL SIGNAL USAGE AND ADJUST THE LENGTH OF THE ALL-RED CLEARANCE INTERVAL TO ACCOUNT FOR SITE CONDITIONS AND TO PROVIDE FOR SAFE AND EFFICIENT TRAFFIC OPERATIONS. UNLESS OTHERWISE INDICATED BY PENNDOT, THE MINIMUM LENGTH OF ALL-RED CLEARANCE INTERVALS SHALL BE AS INDICATED ON THE TABLE ON SHEET 2 OF 4.
15. WHEN NOT IN OPERATION, SIGNAL HEADS SHALL BE REMOVED FROM THE VIEW OF TRAFFIC OR HOODED WITH A MATERIAL THAT COVERS THE SIGNAL INDICATIONS FROM THE VIEW OF TRAFFIC. ALL INAPPROPRIATE SIGNS SHALL ALSO BE REMOVED, COVERED, FOLDED, OR TURNED SO THAT THEY ARE NOT READABLE BY ONCOMING TRAFFIC WHEN THE PORTABLE TRAFFIC CONTROL SIGNAL IS NOT IN OPERATION.
16. SIGNAL MODULES MUST BE REPLACED IN ACCORDANCE WITH THE MANUFACTURERS RECOMMENDATIONS, AND A RECORD OF THIS MUST BE MAINTAINED BY THE USER.
17. ADDITIONAL SIGNS AND DEVICES SHALL BE INSTALLED AS REQUIRED IN PENNDOT PUBLICATIONS 212 AND 213, AND AS REQUIRED BASED ON ACTUAL SITE CONDITIONS.
18. PENNDOT RESERVES THE RIGHT TO INSPECT EACH PORTABLE TRAFFIC CONTROL SIGNAL USAGE. PENNDOT ALSO RESERVES THE RIGHT TO REVOKE A TEMPORARY TRAFFIC CONTROL SIGNAL PERMIT OR TO SUSPEND THE OPERATION OF THE PORTABLE TRAFFIC CONTROL SIGNAL IF THE USER SHALL AT ANY TIME WILLFULLY OR NEGLIGENCELY FAIL TO COMPLY WITH THE CONDITIONS CONTAINED IN THE PERMIT OR PUBLICATION 213, OR FAIL TO MAKE ANY CHANGES IN THE OPERATION OF THE SIGNAL, OR REMOVE IT, WHEN SO ORDERED BY PENNDOT. THE USER SHALL NOT MAKE ANY CHANGE IN THE OPERATION OF THE PORTABLE TRAFFIC CONTROL SIGNAL AS DEFINED IN THE PERMIT DRAWINGS WITHOUT PRIOR WRITTEN APPROVAL OF PENNDOT.

PERMIT NO.: _____

PERMITTEE: _____

PENNDOT
 APPROVAL: _____

DIST. TRAF. ENGINEER

DATE: _____

PATA
 26e M-2

**BLANK
PAGE**

PUBLICATION 213
 SHORT-TERM STATIONARY OPERATION - TWO-LANE, TWO-WAY ROADWAY
 TEMPORARY TRAFFIC CONTROL SIGNALS - PEDESTAL-MOUNTED PORTABLE TRAFFIC CONTROL SIGNALS FOR NON-COMPLEX CONDITIONS

Dist.	County	Route	Sheet
			1 of 4

TEMPORARY TRAFFIC CONTROL SIGNAL PLAN

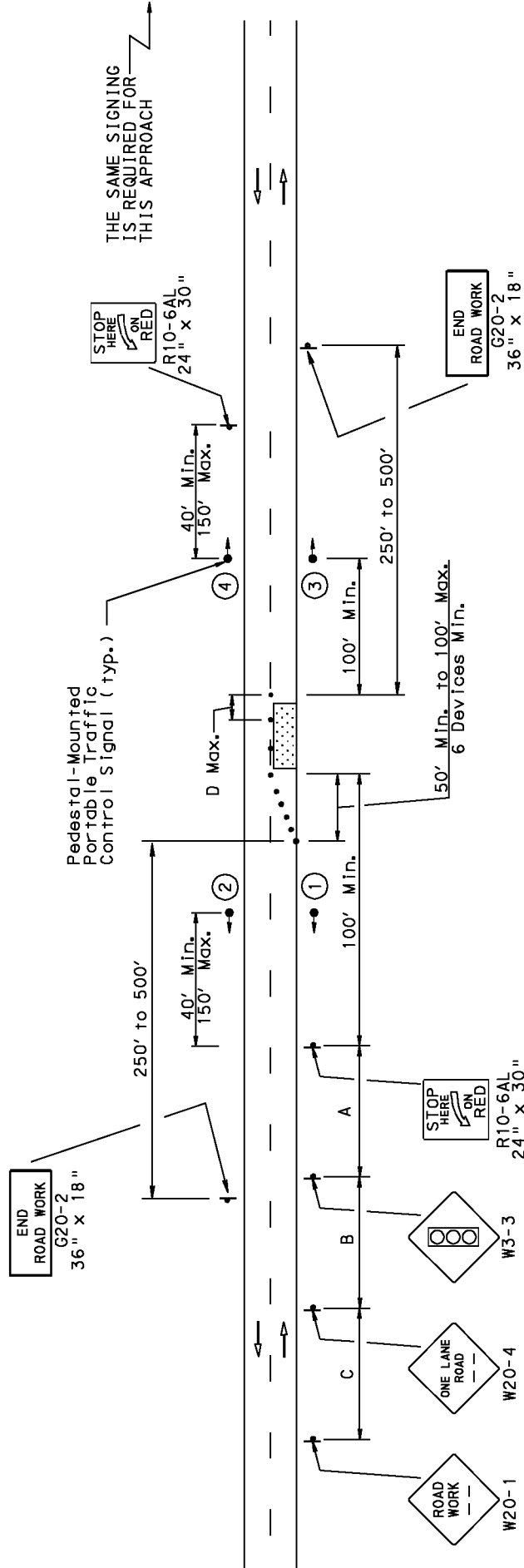

Distance plaques on Advance Warning signs shall be the same series type.

Example: either all XXX ft. or all "AHEAD"

- CONDITION 1: All Highways (except Freeways and Expressways)
- A = 500 ft.
 - B = 500 ft., W20-4 sign distance plaque to read 1000 ft.
 - C = 500 ft., W20-1 sign distance plaque to read 1500 ft.
 - D = 2 times the normal speed limit

- CONDITION 2: For Urban Streets
- A, B and C = 200 ft. and sign distance plaque to read "AHEAD"
 - D = 2 times the normal speed limit

PERMIT NO.: _____

PERMITTEE: _____

PENNDOT APPROVAL: _____

DIST. TRAF. ENGINEER

DATE: _____

PATA
26e NC-1

PUBLICATION 213
 SHORT-TERM STATIONARY OPERATION - TWO-LANE, TWO-WAY ROADWAY
 TEMPORARY TRAFFIC CONTROL SIGNALS - PEDESTAL-MOUNTED PORTABLE TRAFFIC CONTROL SIGNALS FOR NON-COMPLEX CONDITIONS

Dist.	County	Route	Sheet
			2 of 4

SIGNAL	Phase 1			Phase 2			EMERGENCY FLASHING
	1	2	3	1	2	3	
①	G	Y	R	R	R	R	R
②	R	R	R	G	Y	R	R
③							
④							
FIXED							
MINIMUM**	10						
PASSAGE	3						
MAXIMUM							
MEMORY	NL						

ANY FIELD ADJUSTMENT OF "STOP HERE ON RED SIGNALS" REQUIRES NEW CALCULATION OF CLEARANCE INTERVALS IN ACCORDANCE WITH PENNDOT SPECIFICATIONS.

* SEE TABLE AND NOTE 11.
 ** SEE NOTE 12.

All-Red Clearance Interval (See Note 11)

Length of One-Lane, Two-Way Traffic Section between STOP HERE ON RED SIGNS (FT)	Required Minimum Length of All-Red Clearance Interval (SEC)		
	15 MPH	20 MPH	25 MPH
1,000	45	34	27
950	43	32	26
900	41	31	25
850	39	29	23
800	36	27	22
750	34	26	20
700	32	24	19
650	30	22	18
600	27	20	16
550	25	19	15
500	23	17	14
450	20	15	12
400	18	14	11
350	16	12	10
300	14	10	8

SIGNAL REQUIREMENTS

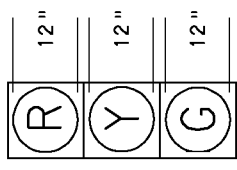

SIGNAL NO'S.
1-2-3-4

NOTE:
ALL SIGNALS TO BE EQUIPPED WITH BACKPLATES.

Signal Face Visibility (See Note 9)	
Normal Speed Limit (MPH)	Minimum Visibility Distance (FT)
25	215
30	270
35	325
40	390
45	460
50	540
55	625

PERMIT NO.:	_____
PERMITTEE:	_____
PENNDOT APPROVAL:	_____
	DIST. TRAF. ENGINEER
DATE:	_____

PUBLICATION 213
 SHORT-TERM STATIONARY OPERATION - TWO-LANE, TWO-WAY ROADWAY
 SIGNALS - PEDESTAL-MOUNTED PORTABLE TRAFFIC CONTROL SIGNALS FOR NON-COMPLEX CONDITIONS

Dist.	County	Route	Sheet
			3 of 4

NOTES

1. THE USE OF PEDESTAL-MOUNTED PORTABLE TRAFFIC CONTROL SIGNALS IN PENNSYLVANIA FOR SHORT-TERM STATIONARY OPERATIONS WITH NON-COMPLEX CONDITIONS SHALL COMPLY WITH PROVISIONS OF THIS FIGURE.
2. THIS FIGURE MAY BE USED IF ALL OF THE FOLLOWING CONDITIONS ARE SATISFIED:
 - a. THE OPERATION IS A STATIONARY, SHORT-TERM OPERATION AS DEFINED IN PENNDOT PUBLICATIONS 212 AND 213.
 - b. THE PORTABLE TRAFFIC CONTROL SIGNALS ARE USED TO CONTROL ONE-LANE, TWO-WAY TRAFFIC, AND NO MORE THAN TWO APPROACHES TO THE WORK ZONE WILL BE CONTROLLED BY THE PORTABLE TRAFFIC CONTROL SIGNALS.
 - c. THERE IS NO AT-GRADE RAILROAD CROSSING WITHIN THE ONE-LANE, TWO-WAY TRAFFIC SECTION (BETWEEN STOP HERE ON RED SIGNS) AND WITHIN 300 FEET OF A PORTABLE TRAFFIC CONTROL SIGNAL.
 - d. NO ROADWAY APPROACH TO THE PORTABLE TRAFFIC CONTROL SIGNAL IS ON A DOWNGRADE OF 5% OR MORE, IF THE NORMAL SPEED LIMIT IS GREATER THAN 35 MILES PER HOUR.
 - e. THERE ARE NO INTERSECTIONS OR UNCONTROLLED COMMERCIAL DRIVEWAYS WITHIN THE ONE-LANE, TWO-WAY TRAFFIC SECTION. THE PROPOSED METHOD OF TRAFFIC CONTROL FOR NON-COMMERCIAL DRIVEWAYS SHALL BE ACCEPTABLE TO PENNDOT.
 - f. THE ROADWAY ADT (AVERAGE DAILY TRAFFIC) IS 10,000 VEHICLES PER DAY OR LESS, AND THE LENGTH OF THE ONE-LANE, TWO-WAY TRAFFIC SECTION (BETWEEN STOP HERE ON RED SIGNS) IS 1,000 FEET OR LESS.
3. ADVANCE WRITTEN APPROVAL MUST BE OBTAINED FROM PENNDOT PRIOR TO USING PORTABLE TRAFFIC CONTROL SIGNALS FOR SHORT-TERM OPERATIONS ON ANY PUBLIC HIGHWAY. A PENNDOT TEMPORARY TRAFFIC CONTROL SIGNAL PERMIT IS REQUIRED FOR SHORT-TERM OPERATIONS, AND A COPY MUST BE MAINTAINED ON-SITE DURING THE PERIOD OF PORTABLE TRAFFIC CONTROL SIGNAL USAGE.
4. SUBMIT A COMPLETED APPLICATION FOR A PERMIT TO OPERATE TEMPORARY TRAFFIC CONTROL SIGNALS TO THE APPROPRIATE PENNDOT ENGINEERING DISTRICT OFFICE SO THAT IT IS RECEIVED AT LEAST 3 FULL WORKING DAYS BEFORE THE DESIRED BEGINNING TIME OF THE PORTABLE TRAFFIC CONTROL SIGNAL USAGE, EXCEPT FOR EMERGENCY WORK AS DEFINED IN PENNDOT PUBLICATION 212.
5. REFER TO APPENDIX A OF THIS PUBLICATION FOR ADDITIONAL GUIDANCE AND ACCEPTANCE PROCEDURES PERTAINING TO PORTABLE TRAFFIC CONTROL SIGNALS.
6. THE DESIGN AND APPLICATION OF THE PORTABLE TRAFFIC CONTROL SIGNALS SHALL COMPLY WITH THE MOST CURRENT VERSION OF PENNDOT PUBLICATIONS 212, 213, AND 149.
7. SIGNAL SUPPORTS SHOULD BE A MINIMUM OF 2 FEET OFF THE EDGE OF TRAVEL WAY. IF THIS IS NOT POSSIBLE, THE SUPPORTS SHALL BE ADEQUATELY PROTECTED BY BARRIER, GUIDERAIL, OR CHANNELIZING DEVICES.
8. THE BOTTOM OF THE HOUSING OF A SIGNAL FACE THAT IS NOT MOUNTED OVER THE ROADWAY SHALL BE AT LEAST 8 FEET, BUT NOT MORE THAN 15 FEET ABOVE THE SIDEWALK OR, IF THERE IS NO SIDEWALK, ABOVE THE PAVEMENT GRADE AT THE CENTER OF THE ROADWAY.
9. A MINIMUM OF TWO SIGNAL FACES ON EACH APPROACH SHOULD BE CONTINUOUSLY VISIBLE TO APPROACHING TRAFFIC FROM A POINT MEETING THE SIGNAL VISIBILITY DISTANCES SPECIFIED IN THE TABLE ON SHEET 2 OF 3.
10. THE LENGTH OF YELLOW CHANGE INTERVALS IS NORMALLY IN THE RANGE FROM ABOUT 3 SECONDS TO 6 SECONDS. USE A 5-SECOND YELLOW CHANGE INTERVAL, OR AN APPROPRIATE ALTERNATE VALUE FROM PENNDOT PUBLICATION 149M BASED ON ACTUAL SITE CONDITIONS.

(NOTES CONT'D. ON SHEET 4)

PERMIT NO.:	
PERMITTEE:	
PENNDOT APPROVAL:	DIST. TRAF. ENGINEER
DATE:	

PATA
26e NC-1

PUBLICATION 213
 SHORT-TERM STATIONARY OPERATION - TWO-LANE, TWO-WAY ROADWAY
 TEMPORARY TRAFFIC CONTROL SIGNALS - PEDESTAL-MOUNTED PORTABLE TRAFFIC CONTROL SIGNALS FOR NON-COMPLEX CONDITIONS

Dist.	County	Route	Sheet
			4 of 4

NOTES

(CONT'D. FROM SHEET 3)

11. AN ALL-RED CLEARANCE INTERVAL MUST BE USED. THE LENGTH OF THE ALL-RED CLEARANCE INTERVAL IS BASED ON THE LENGTH OF THE ONE-LANE, TWO-WAY TRAFFIC SECTION CONTROLLED BY THE PORTABLE TRAFFIC CONTROL SIGNALS AND THE SPEED OF TRAFFIC THROUGH THAT SECTION. MONITOR TRAFFIC OPERATIONS DURING THE PERIOD OF PORTABLE TRAFFIC CONTROL SIGNAL USAGE AND ADJUST THE LENGTH OF THE ALL-RED CLEARANCE INTERVAL TO ACCOUNT FOR SITE CONDITIONS AND TO PROVIDE FOR SAFE AND EFFICIENT TRAFFIC OPERATIONS. UNLESS OTHERWISE INDICATED BY PENNDOT, THE MINIMUM LENGTH OF ALL-RED CLEARANCE INTERVALS SHALL BE AS INDICATED ON THE TABLE ON SHEET 2 OF 4.
12. FOR FIXED TIME AND ACTUATED OPERATIONS, THE MINIMUM GREEN INTERVAL PROVIDED FOR EACH APPROACH SHALL BE 10 SECONDS, UNLESS OTHERWISE INDICATED BY PENNDOT. THE LENGTH OF GREEN INTERVALS SHOULD BE SUCH AS TO PROVIDE FOR SAFE AND EFFICIENT TRAFFIC OPERATIONS. USE GREEN INTERVALS AS INDICATED ON THE PERMIT DRAWING. IF THERE IS NO PERMIT DRAWING, MONITOR TRAFFIC OPERATIONS AS TRAFFIC VOLUMES CHANGE THROUGHOUT THE PERIOD OF PORTABLE TRAFFIC CONTROL SIGNAL USAGE, AND ADJUST GREEN INTERVALS TO PROVIDE FOR SAFE AND EFFICIENT TRAFFIC OPERATIONS.
13. WHEN NOT IN OPERATION, SIGNAL HEADS SHALL BE REMOVED FROM THE VIEW OF TRAFFIC OR HOODED WITH A MATERIAL THAT COVERS THE SIGNAL INDICATIONS FROM THE VIEW OF TRAFFIC. ALL INAPPROPRIATE SIGNS SHALL ALSO BE REMOVED, COVERED, FOLDED, OR TURNED SO THAT THEY ARE NOT READABLE BY ONCOMING TRAFFIC WHEN THE PORTABLE TRAFFIC CONTROL SIGNAL IS NOT IN OPERATION.
14. SIGNAL MODULES MUST BE REPLACED IN ACCORDANCE WITH THE MANUFACTURERS RECOMMENDATIONS, AND A RECORD OF THIS MUST BE MAINTAINED BY THE USER.
15. ADDITIONAL SIGNS AND DEVICES SHALL BE INSTALLED AS REQUIRED IN PENNDOT PUBLICATIONS 212 AND 213, AND AS REQUIRED BASED ON ACTUAL SITE CONDITIONS.
16. PENNDOT RESERVES THE RIGHT TO INSPECT EACH PORTABLE TRAFFIC CONTROL SIGNAL USAGE. PENNDOT ALSO RESERVES THE RIGHT TO REVOKE A TEMPORARY TRAFFIC CONTROL SIGNAL PERMIT OR TO SUSPEND THE OPERATION OF THE PORTABLE TRAFFIC CONTROL SIGNAL IF THE USER SHALL AT ANY TIME WILLFULLY OR NEGLIGENTLY FAIL TO COMPLY WITH THE CONDITIONS CONTAINED IN THE PERMIT OR PUBLICATION 213, OR FAIL TO MAKE ANY CHANGES IN THE OPERATION OF THE SIGNAL, OR REMOVE IT, WHEN SO ORDERED BY PENNDOT. THE USER SHALL NOT MAKE ANY CHANGE IN THE OPERATION OF THE PORTABLE TRAFFIC CONTROL SIGNAL AS DEFINED IN THE PERMIT DRAWINGS WITHOUT PRIOR WRITTEN APPROVAL OF PENNDOT.

PATA
26e NC-1

PERMIT NO.:	
PERMITTEE:	
PENNDOT APPROVAL:	DIST. TRAF. ENGINEER
DATE:	

PUBLICATION 213
 SHORT-TERM STATIONARY OPERATION - TWO-LANE, TWO WAY ROADWAY
 TEMPORARY TRAFFIC CONTROL SIGNALS - TRAILER-MOUNTED PORTABLE TRAFFIC CONTROL SIGNALS FOR NON-COMPLEX CONDITIONS

Dist.	County	Route	Sheet
			1 of 5

TEMPORARY TRAFFIC CONTROL SIGNAL PLAN

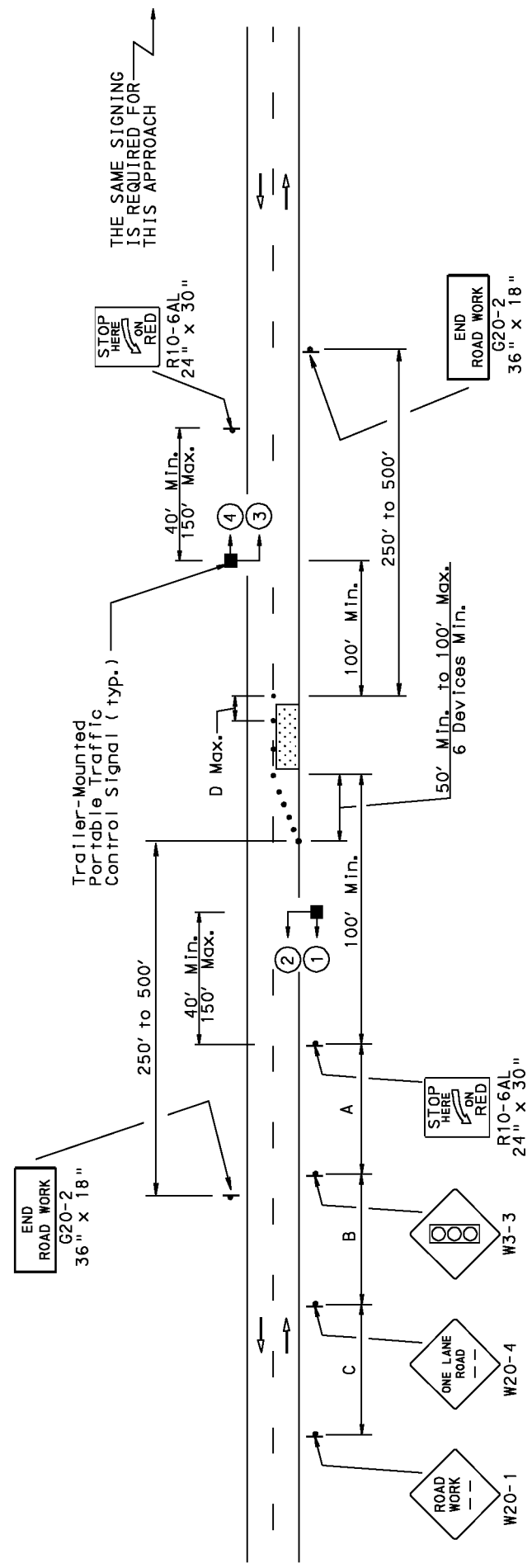

NOTE
 Refer to Sheet 3 of 5 for Alternate Trailer-Mounted Portable Traffic Signal Placement.

Distance plaques on Advance Warning signs shall be the same series type.

Example: either all XXX ft. or all "AHEAD"

- CONDITION 1:** All Highways (except Freeways and Expressways)
- A = 500 ft.
 - B = 500 ft., W20-4 sign distance plaque to read 1000 ft.
 - C = 500 ft., W20-1 sign distance plaque to read 1500 ft.
 - D = 2 times the normal speed limit

- CONDITION 2:** For Urban Streets
- A, B and C = 200 ft. and sign distance plaque to read "AHEAD"
 - D = 2 times the normal speed limit

PERMIT NO.:

PERMITTEE:

PENNDOT APPROVAL:

DIST. TRAF. ENGINEER

DATE:

PATA
 26e NC-2

PUBLICATION 213
 SHORT-TERM STATIONARY OPERATION - TWO-LANE, TWO WAY ROADWAY
 TEMPORARY TRAFFIC CONTROL SIGNALS - TRAILER-MOUNTED PORTABLE TRAFFIC CONTROL SIGNALS FOR NON-COMPLEX CONDITIONS

Dist.	County	Route	Sheet
			2 of 5

SIGNAL	Phase 1			Phase 2			EMERGENCY FLASHING
	1	2	3	1	2	3	
①	G	Y	R	R	R	R	R
②	R	R	R	G	Y	R	R
③							
④							
FIXED							
MINIMUM **	10				5	*	
PASSAGE	3						
MAXIMUM							
MEMORY	NL			NL			

ANY FIELD ADJUSTMENT OF "STOP HERE ON RED SIGNS" REQUIRES NEW CALCULATION OF CLEARANCE INTERVALS IN ACCORDANCE WITH PENNDOT SPECIFICATIONS.

* SEE TABLE AND NOTE 11.
 ** SEE NOTE 12.

All-Red Clearance Interval (See Note 11)

Length of One-Lane, Two-Way Traffic Section between STOP HERE ON RED SIGNS (FT)	Required Minimum Length of All-Red Clearance Interval (SEC)		
	15 MPH	20 MPH	25 MPH
1,000	45	34	27
950	43	32	26
900	41	31	25
850	39	29	23
800	36	27	22
750	34	26	20
700	32	24	19
650	30	22	18
600	27	20	16
550	25	19	15
500	23	17	14
450	20	15	12
400	18	14	11
350	16	12	10
300	14	10	8

SIGNAL REQUIREMENTS

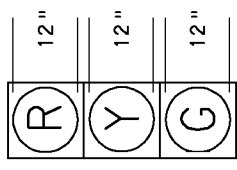

SIGNAL NO'S.
 1-2-3-4

NOTE:
 ALL SIGNALS TO BE EQUIPPED WITH BACKPLATES.

Signal Face Visibility (See Note 9)	
Normal Speed Limit (MPH)	Minimum Visibility Distance (FT)
25	215
30	270
35	325
40	390
45	460
50	540
55	625

PERMIT NO.: _____
 PERMITTEE: _____
 PENNDOT APPROVAL: _____
 DIST. TRAF. ENGINEER _____
 DATE: _____

Dist.	County	Route	Sheet
			3 of 5

ALTERNATE TRAILER-MOUNTED PORTABLE TRAFFIC SIGNAL PLACEMENTS

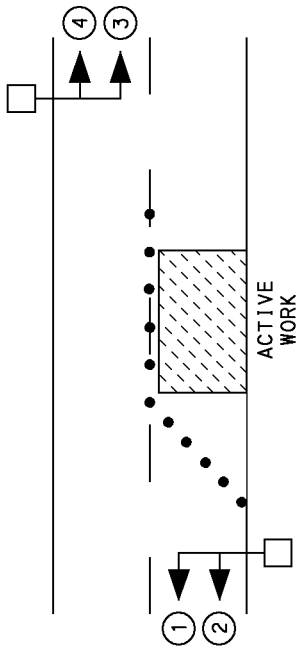

OPTION 1

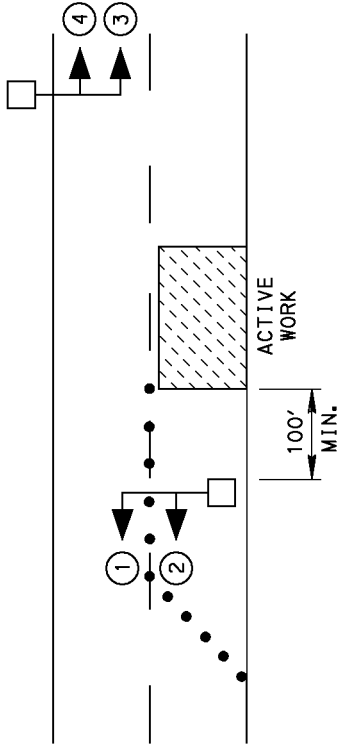

OPTION 2

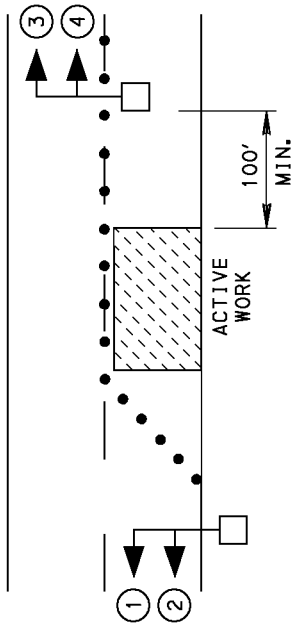

OPTION 3

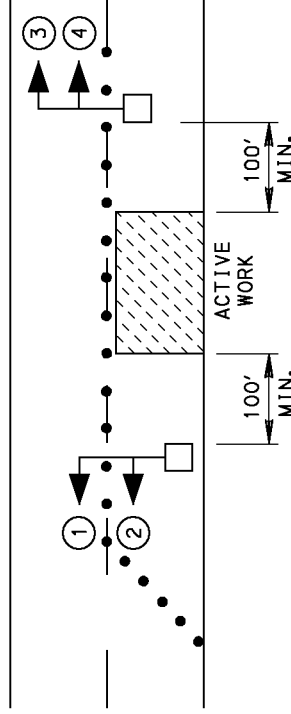

OPTION 4

PERMIT NO.:

PERMITTEE:

PENNDOT APPROVAL:

DIST. TRAF. ENGINEER

DATE:

PUBLICATION 213
 SHORT-TERM STATIONARY OPERATION - TWO-LANE, TWO WAY ROADWAY
 TEMPORARY TRAFFIC CONTROL SIGNALS - TRAILER-MOUNTED PORTABLE TRAFFIC CONTROL SIGNALS FOR NON-COMPLEX CONDITIONS

Dist.	County	Route	Sheet
			4 of 5

NOTES

1. THE USE OF TRAILER-MOUNTED PORTABLE TRAFFIC CONTROL SIGNALS IN PENNSYLVANIA FOR SHORT-TERM STATIONARY OPERATIONS WITH NON-COMPLEX CONDITIONS SHALL COMPLY WITH PROVISIONS OF THIS FIGURE.
2. THIS FIGURE MAY BE USED IF ALL OF THE FOLLOWING CONDITIONS ARE SATISFIED:
 - a. THE OPERATION IS A STATIONARY, SHORT-TERM OPERATION AS DEFINED IN PENNDOT PUBLICATIONS 212 AND 213.
 - b. THE PORTABLE TRAFFIC CONTROL SIGNALS ARE USED TO CONTROL ONE-LANE, TWO-WAY TRAFFIC, AND NO MORE THAN TWO APPROACHES TO THE WORK ZONE WILL BE CONTROLLED BY THE PORTABLE TRAFFIC CONTROL SIGNALS.
 - c. THERE IS NO AT-GRADE RAILROAD CROSSING WITHIN THE ONE-LANE, TWO-WAY TRAFFIC SECTION (BETWEEN STOP HERE ON RED SIGNS) AND WITHIN 300 FEET OF A PORTABLE TRAFFIC CONTROL SIGNAL.
 - d. NO ROADWAY APPROACH TO THE PORTABLE TRAFFIC CONTROL SIGNAL IS ON A DOWNGRADE OF 5% OR MORE, IF THE NORMAL SPEED LIMIT IS GREATER THAN 35 MILES PER HOUR.
 - e. THERE ARE NO INTERSECTIONS OR UNCONTROLLED COMMERCIAL DRIVEWAYS WITHIN THE ONE-LANE, TWO-WAY TRAFFIC SECTION. THE PROPOSED METHOD OF TRAFFIC CONTROL FOR NON-COMMERCIAL DRIVEWAYS SHALL BE ACCEPTABLE TO PENNDOT.
 - f. THE ROADWAY ADT (AVERAGE DAILY TRAFFIC) IS 10,000 VEHICLES PER DAY OR LESS, AND THE LENGTH OF THE ONE-LANE, TWO-WAY TRAFFIC SECTION (BETWEEN STOP HERE ON RED SIGNS) IS 1,000 FEET OR LESS.
3. ADVANCE WRITTEN APPROVAL MUST BE OBTAINED FROM PENNDOT PRIOR TO USING PORTABLE TRAFFIC CONTROL SIGNALS FOR SHORT-TERM OPERATIONS ON ANY PUBLIC HIGHWAY. A PENNDOT TEMPORARY TRAFFIC CONTROL SIGNAL PERMIT IS REQUIRED FOR SHORT-TERM OPERATIONS, AND A COPY MUST BE MAINTAINED ON-SITE DURING THE PERIOD OF PORTABLE TRAFFIC CONTROL SIGNAL USAGE.
4. SUBMIT A COMPLETED APPLICATION FOR A PERMIT TO OPERATE TEMPORARY TRAFFIC CONTROL SIGNALS TO THE APPROPRIATE PENNDOT ENGINEERING DISTRICT OFFICE SO THAT IT IS RECEIVED AT LEAST 3 FULL WORKING DAYS BEFORE THE DESIRED BEGINNING TIME OF THE PORTABLE TRAFFIC CONTROL SIGNAL USAGE, EXCEPT FOR EMERGENCY WORK AS DEFINED IN PENNDOT PUBLICATION 212.
5. REFER TO APPENDIX A OF THIS PUBLICATION FOR ADDITIONAL GUIDANCE AND ACCEPTANCE PROCEDURES PERTAINING TO PORTABLE TRAFFIC CONTROL SIGNALS.
6. THE DESIGN AND APPLICATION OF THE PORTABLE TRAFFIC CONTROL SIGNALS SHALL COMPLY WITH THE MOST CURRENT VERSION OF PENNDOT PUBLICATIONS 212, 213, AND 149.
7. SIGNAL SUPPORTS SHOULD BE A MINIMUM OF 2 FEET OFF THE EDGE OF TRAVEL WAY. IF THIS IS NOT POSSIBLE, THE SUPPORTS SHALL BE ADEQUATELY PROTECTED BY BARRIER, GUIDERAIL, OR CHANNELIZING DEVICES.
8. THE BOTTOM OF THE HOUSING OF A SIGNAL FACE SUSPENDED OVER THE ROADWAY SHALL BE A MINIMUM OF 15 FEET, BUT NOT MORE THAN 19 FEET ABOVE THE PAVEMENT. THE BOTTOM OF THE HOUSING OF A SIGNAL FACE THAT IS NOT MOUNTED OVER THE ROADWAY SHALL BE AT LEAST 8 FEET, BUT NOT MORE THAN 15 FEET ABOVE THE SIDEWALK OR, IF THERE IS NO SIDEWALK, ABOVE THE PAVEMENT GRADE AT THE CENTER OF THE ROADWAY.
9. A MINIMUM OF TWO SIGNAL FACES ON EACH APPROACH SHOULD BE CONTINUOUSLY VISIBLE TO APPROACHING TRAFFIC FROM A POINT MEETING THE SIGNAL VISIBILITY DISTANCES SPECIFIED IN THE TABLE ON SHEET 2 OF 3.
10. THE LENGTH OF YELLOW CHANGE INTERVALS IS NORMALLY IN THE RANGE FROM ABOUT 3 SECONDS TO 6 SECONDS. USE A 5-SECOND YELLOW CHANGE INTERVAL, OR AN APPROPRIATE ALTERNATE VALUE FROM PENNDOT PUBLICATION 149M BASED ON ACTUAL SITE CONDITIONS.

(NOTES CONT'D. ON SHEET 4)

PERMIT NO.:	
PERMITTEE:	
PENNDOT APPROVAL:	DIST. TRAF. ENGINEER
DATE:	

PUBLICATION 213
 SHORT-TERM STATIONARY OPERATION - TWO-LANE, TWO WAY ROADWAY
 TEMPORARY TRAFFIC CONTROL SIGNALS - TRAILER-MOUNTED PORTABLE TRAFFIC CONTROL SIGNALS FOR NON-COMPLEX CONDITIONS

Dist.	County	Route	Sheet
			5 of 5

NOTES

(CONT' D. FROM SHEET 3)

11. AN ALL-RED CLEARANCE INTERVAL MUST BE USED. THE LENGTH OF THE ALL-RED CLEARANCE INTERVAL IS BASED ON THE LENGTH OF THE ONE-LANE, TWO-WAY TRAFFIC SECTION CONTROLLED BY THE PORTABLE TRAFFIC CONTROL SIGNALS AND THE SPEED OF TRAFFIC THROUGH THAT SECTION. MONITOR TRAFFIC OPERATIONS DURING THE PERIOD OF PORTABLE TRAFFIC CONTROL SIGNAL USAGE AND ADJUST THE LENGTH OF THE ALL-RED CLEARANCE INTERVAL TO ACCOUNT FOR SITE CONDITIONS AND TO PROVIDE FOR SAFE AND EFFICIENT TRAFFIC OPERATIONS. UNLESS OTHERWISE INDICATED BY PENNDOT, THE MINIMUM LENGTH OF ALL-RED CLEARANCE INTERVALS SHALL BE AS INDICATED ON THE TABLE ON SHEET 2 OF 4.

12. FOR FIXED TIME AND ACTUATED OPERATIONS, THE MINIMUM GREEN INTERVAL PROVIDED FOR EACH APPROACH SHALL BE 10 SECONDS, UNLESS OTHERWISE INDICATED BY PENNDOT. THE LENGTH OF GREEN INTERVALS SHOULD BE SUCH AS TO PROVIDE FOR SAFE AND EFFICIENT TRAFFIC OPERATIONS. USE GREEN INTERVALS AS INDICATED ON THE PERMIT DRAWING. IF THERE IS NO PERMIT DRAWING, MONITOR TRAFFIC OPERATIONS AS TRAFFIC VOLUMES CHANGE THROUGHOUT THE PERIOD OF PORTABLE TRAFFIC CONTROL SIGNAL USAGE AND ADJUST GREEN INTERVALS TO PROVIDE FOR SAFE AND EFFICIENT TRAFFIC OPERATIONS.

13. WHEN NOT IN OPERATION, SIGNAL HEADS SHALL BE REMOVED FROM THE VIEW OF TRAFFIC OR HOODED WITH A MATERIAL THAT COVERS THE SIGNAL INDICATIONS FROM THE VIEW OF TRAFFIC. ALL INAPPROPRIATE SIGNS SHALL ALSO BE REMOVED, COVERED, FOLDED, OR TURNED SO THAT THEY ARE NOT READABLE BY ONCOMING TRAFFIC WHEN THE PORTABLE TRAFFIC CONTROL SIGNAL IS NOT IN OPERATION.

14. SIGNAL MODULES MUST BE REPLACED IN ACCORDANCE WITH THE MANUFACTURERS RECOMMENDATIONS, AND A RECORD OF THIS MUST BE MAINTAINED BY THE USER.

15. ADDITIONAL SIGNS AND DEVICES SHALL BE INSTALLED AS REQUIRED IN PENNDOT PUBLICATIONS 212 AND 213, AND AS REQUIRED BASED ON ACTUAL SITE CONDITIONS.

16. PENNDOT RESERVES THE RIGHT TO INSPECT EACH PORTABLE TRAFFIC CONTROL SIGNAL USAGE. PENNDOT ALSO RESERVES THE RIGHT TO REVOKE A TEMPORARY TRAFFIC CONTROL SIGNAL PERMIT OR TO SUSPEND THE OPERATION OF THE PORTABLE TRAFFIC CONTROL SIGNAL IF THE USER SHALL AT ANY TIME WILLFULLY OR NEGLIGENTLY FAIL TO COMPLY WITH THE CONDITIONS CONTAINED IN THE PERMIT OR PUBLICATION 213, OR FAIL TO MAKE ANY CHANGES IN THE OPERATION OF THE SIGNAL, OR REMOVE IT, WHEN SO ORDERED BY PENNDOT. THE USER SHALL NOT MAKE CHANGE IN THE OPERATION OF THE PORTABLE TRAFFIC CONTROL SIGNAL AS DEFINED IN THE PERMIT DRAWINGS WITHOUT PRIOR WRITTEN APPROVAL OF PENNDOT.

PERMIT NO.:	
PERMITTEE:	
PENNDOT APPROVAL:	DIST. TRAF. ENGINEER
DATE:	

PATA
26e NC-2

**BLANK
PAGE**

PUBLICATION 213
 SHORT-TERM STATIONARY OPERATION - TWO-LANE, TWO-WAY ROADWAY
 TEMPORARY TRAFFIC CONTROL SIGNALS - PEDESTAL-MOUNTED PORTABLE TRAFFIC CONTROL SIGNALS FOR COMPLEX CONDITIONS

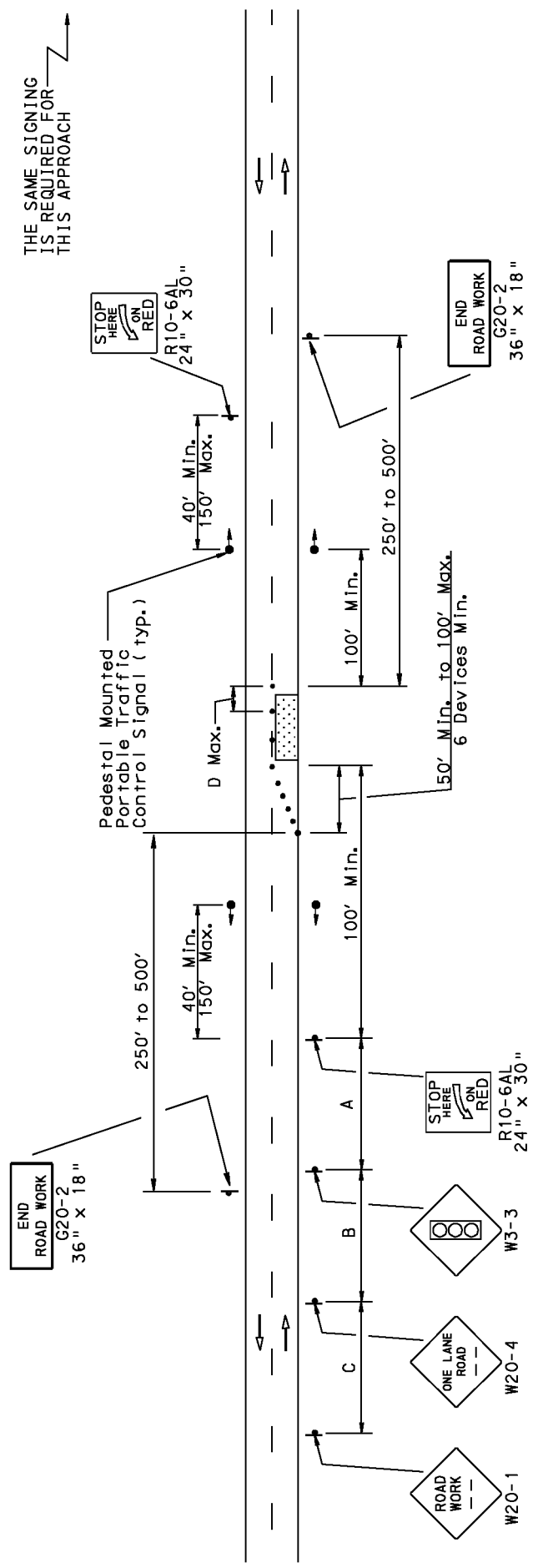

Distance plaques on Advance Warning signs shall be the same series type.

Example: either all XXX ft. or all "AHEAD"

CONDITION 1: All Highways (except Freeways and Expressways)
 A = 500 ft.
 B = 500 ft., W20-4 sign distance plaque to read 1000 ft.
 C = 500 ft., W20-1 sign distance plaque to read 1500 ft.
 D = 2 times the normal speed limit

CONDITION 2: For Urban Streets
 A, B and C = 200 ft. and sign distance plaque to read "AHEAD"
 D = 2 times the normal speed limit

PUBLICATION 213
 SHORT-TERM STATIONARY OPERATION - TWO-LANE, TWO-WAY ROADWAY
 TEMPORARY TRAFFIC CONTROL SIGNALS - PEDESTAL-MOUNTED PORTABLE TRAFFIC CONTROL SIGNALS FOR COMPLEX CONDITIONS

All-Red Clearance Interval (See Note 10)

Length of One-Lane, Two-Way Traffic Section Between STOP HERE ON RED SIGNS (FT)	Required Minimum Length of All-Red Clearance Interval (SEC)		
	15 MPH	20 MPH	25 MPH
1,000	45	34	27
950	43	32	26
900	41	31	25
850	39	29	23
800	36	27	22
750	34	26	20
700	32	24	19
650	30	22	18
600	27	20	16
550	25	19	15
500	23	17	14
450	20	15	12
400	18	14	11
350	16	12	10
300	14	10	8

Signal Face Visibility (See Note 7)	
Normal Speed Limit (MPH)	Minimum Visibility Distance (FT)
25	215
30	270
35	325
40	390
45	460
50	540
55	625

NOTES

1. THE USE OF MANUALLY-CONTROLLED, PEDESTAL-MOUNTED PORTABLE TRAFFIC CONTROL SIGNALS IN PENNSYLVANIA FOR SHORT-TERM STATIONARY OPERATIONS WITH COMPLEX CONDITIONS SHALL COMPLY WITH PROVISIONS OF THIS FIGURE.
2. ADVANCE WRITTEN APPROVAL MUST BE OBTAINED FROM PENNDOT PRIOR TO USING PORTABLE TRAFFIC CONTROL SIGNALS FOR SHORT-TERM STATIONARY OPERATIONS ON ANY PUBLIC HIGHWAY EXCEPT FOR EMERGENCY WORK AS DEFINED IN PENNDOT PUBLICATION 213. A PENNDOT TEMPORARY TRAFFIC CONTROL SIGNAL PERMIT AND SITE-SPECIFIC DRAWING ARE REQUIRED FOR SHORT-TERM OPERATIONS WITH COMPLEX CONDITIONS, AND A COPY MUST BE MAINTAINED ON-SITE DURING THE PERIOD OF THE TEMPORARY TRAFFIC CONTROL SIGNAL USAGE.
3. REFER TO APPENDIX A OF THIS PUBLICATION FOR ADDITIONAL GUIDANCE AND ACCEPTANCE PROCEDURES PERTAINING TO PORTABLE TRAFFIC CONTROL SIGNALS.
4. THE DESIGN AND APPLICATION OF THE PORTABLE TRAFFIC CONTROL SIGNALS SHALL COMPLY WITH THE MOST CURRENT VERSION OF PENNDOT PUBLICATIONS 212, 213, AND 149.
5. SIGNAL SUPPORTS SHOULD BE A MINIMUM OF 2 FEET OFF THE EDGE OF TRAVEL WAY. IF THIS IS NOT POSSIBLE, THE SUPPORTS SHALL BE ADEQUATELY PROTECTED BY BARRIER, GUIDERAIL, OR CHANNELIZING DEVICES.
6. THE BOTTOM OF THE HOUSING OF A SIGNAL FACE THAT IS NOT MOUNTED OVER THE ROADWAY SHALL BE AT LEAST 8 FEET, BUT NOT MORE THAN 15 FEET ABOVE THE SIDEWALK OR, IF THERE IS NO SIDEWALK, ABOVE THE PAVEMENT GRADE AT THE CENTER OF THE ROADWAY.
7. A MINIMUM OF TWO SIGNAL FACES ON EACH APPROACH SHOULD BE CONTINUOUSLY VISIBLE TO APPROACHING TRAFFIC FROM A POINT MEETING THE SIGNAL VISIBILITY DISTANCES SPECIFIED IN THE TABLE ON SHEET 2 OF 3.
8. ALL SIGNALS LENSES SHALL BE 12 INCHES IN DIAMETER.
9. THE LENGTH OF YELLOW CHANGE INTERVALS IS NORMALLY IN THE RANGE FROM ABOUT 3 SECONDS TO 6 SECONDS. USE A 5-SECOND YELLOW CHANGE INTERVAL, OR AN APPROPRIATE ALTERNATE VALUE FROM PENNDOT PUBLICATION 149M BASED ON ACTUAL SITE CONDITIONS.
10. ONE-ALL-RED CLEARANCE INTERVAL MUST BE USED. THE LENGTH OF THE ALL-RED CLEARANCE INTERVAL IS BASED ON THE LENGTH OF THE ONE-LANE, TWO-WAY TRAFFIC SECTION CONTROLLED BY THE PORTABLE TRAFFIC CONTROL SIGNALS AND THE SPEED OF TRAFFIC THROUGH THAT SECTION. MONITOR TRAFFIC OPERATIONS DURING THE PERIOD OF PORTABLE TRAFFIC CONTROL SIGNAL USAGE AND ADJUST THE LENGTH OF THE ALL-RED CLEARANCE INTERVAL TO ACCOUNT FOR SITE CONDITIONS AND TO PROVIDE FOR SAFE AND EFFICIENT TRAFFIC OPERATIONS. UNLESS OTHERWISE INDICATED BY PENNDOT, THE MINIMUM LENGTH OF ALL-RED CLEARANCE INTERVALS SHALL BE AS INDICATED ON THE TABLE ON SHEET 2 OF 3.
11. FOR FIXED TIME AND ACTUATED OPERATION, THE MINIMUM GREEN INTERVAL PROVIDED FOR EACH APPROACH SHALL BE 10 SECONDS, UNLESS OTHERWISE INDICATED BY PENNDOT. THE LENGTH OF GREEN INTERVALS SHOULD BE SUCH AS TO PROVIDE FOR SAFE AND EFFICIENT TRAFFIC OPERATIONS. USE GREEN INTERVALS AS INDICATED ON THE PERMIT DRAWING. MONITOR TRAFFIC OPERATIONS AS TRAFFIC VOLUMES CHANGE THROUGHOUT THE PERIOD OF PORTABLE TRAFFIC CONTROL SIGNAL USAGE AND ADJUST GREEN INTERVALS TO PROVIDE FOR SAFE AND EFFICIENT TRAFFIC OPERATIONS.
12. WHEN NOT IN OPERATION, SIGNAL HEADS SHALL BE REMOVED FROM THE VIEW OF TRAFFIC OR HOODED WITH A MATERIAL THAT COVERS THE SIGNAL INDICATIONS FROM THE VIEW OF TRAFFIC. ALL INAPPROPRIATE SIGNS SHALL ALSO BE REMOVED, COVERED, FOLDED, OR TURNED SO THAT THEY ARE NOT READABLE BY ONCOMING TRAFFIC WHEN THE PORTABLE TRAFFIC CONTROL SIGNAL IS NOT IN OPERATION.
13. WHEN THE TEMPORARY TRAFFIC CONTROL SIGNAL IS CHANGED TO FLASHING MODE, EITHER MANUALLY OR AUTOMATICALLY, RED SIGNAL INDICATIONS SHALL BE FLASHED TO BOTH APPROACHES.
14. SIGNAL MODULES MUST BE REPLACED IN ACCORDANCE WITH THE MANUFACTURERS RECOMMENDATIONS, AND A RECORD OF THIS MUST BE MAINTAINED BY THE USER.
15. ADDITIONAL SIGNS AND DEVICES SHALL BE INSTALLED AS REQUIRED IN PENNDOT PUBLICATIONS 212 AND 213, AND AS REQUIRED BASED ON ACTUAL SITE CONDITIONS.
16. PENNDOT RESERVES THE RIGHT TO INSPECT EACH PORTABLE TRAFFIC CONTROL SIGNAL USAGE. PENNDOT ALSO RESERVES THE RIGHT TO REVOKE A TEMPORARY TRAFFIC CONTROL SIGNAL PERMIT OR TO SUSPEND THE OPERATION OF THE PORTABLE TRAFFIC CONTROL SIGNAL IF THE USER SHALL AT ANY TIME WILLFULLY OR NEGLIGENTLY FAIL TO COMPLY WITH THE CONDITIONS CONTAINED IN THE PERMIT OR PUBLICATION 213, OR FAIL TO MAKE ANY CHANGES IN THE OPERATION OF THE SIGNAL, OR REMOVE IT, WHEN SO ORDERED BY PENNDOT. THE USER SHALL NOT MAKE ANY CHANGE IN THE OPERATION OF THE PORTABLE TRAFFIC CONTROL SIGNAL AS DEFINED IN THE PERMIT DRAWINGS WITHOUT PRIOR WRITTEN APPROVAL OF PENNDOT.

**BLANK
PAGE**

PUBLICATION 213
 SHORT-TERM STATIONARY OPERATION - TWO LANE, TWO-WAY ROADWAY
 TEMPORARY TRAFFIC CONTROL SIGNALS - TRAILER-MOUNTED PORTABLE TRAFFIC CONTROL SIGNALS FOR COMPLEX CONDITIONS

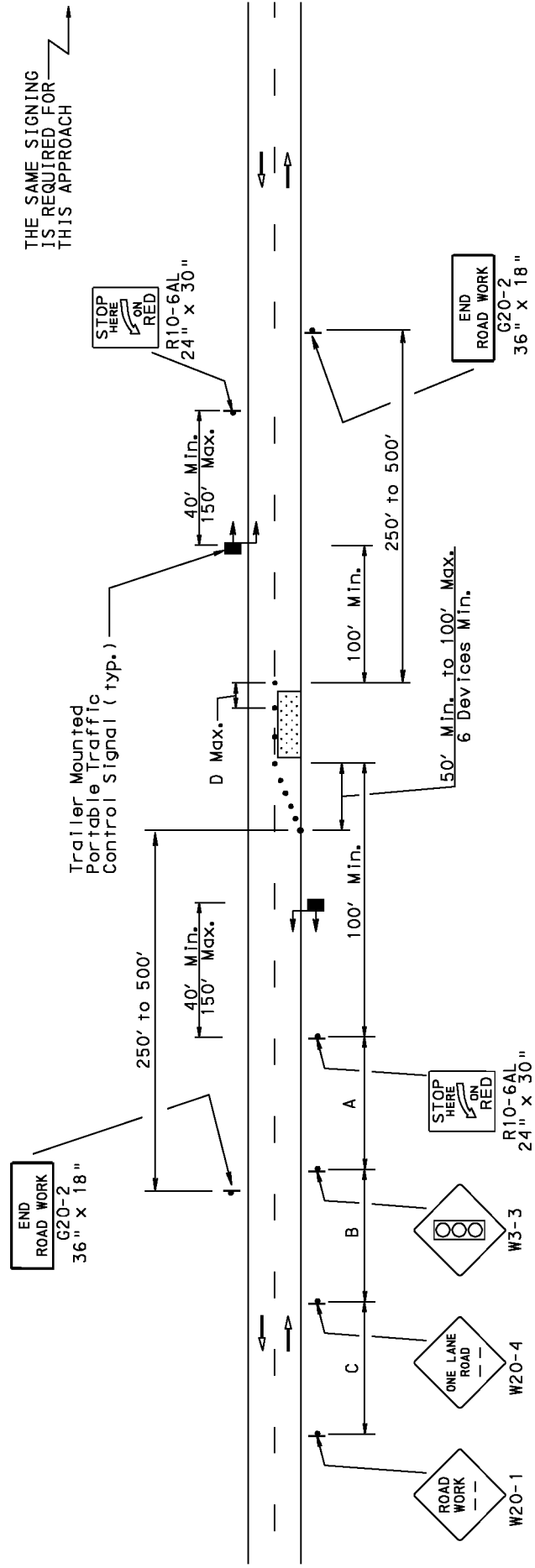

NOTE
 Refer to Sheet 3 of 4 for Alternate Trailer-Mounted Portable Traffic Signal Placement.

Distance plaques on Advance Warning signs shall be the same series type.
 Example: either all XXX ft. or all "AHEAD"

CONDITION 1: All Highways (except Freeways and Expressways)
 A = 500 ft.
 B = 500 ft., W20-4 sign distance plaque to read 1000 ft.
 C = 500 ft., W20-1 sign distance plaque to read 1500 ft.
 D = 2 times the normal speed limit

CONDITION 2: For Urban Streets
 A, B and C = 200 ft. and sign distance plaque to read "AHEAD"
 D = 2 times the normal speed limit

PUBLICATION 213
 SHORT-TERM STATIONARY OPERATION - TWO LANE, TWO-WAY ROADWAY
 TEMPORARY TRAFFIC CONTROL SIGNALS - TRAILER-MOUNTED PORTABLE TRAFFIC CONTROL SIGNALS FOR COMPLEX CONDITIONS

All-Red Clearance Interval (See Note 10)

Length of One-Lane, Two-Way Traffic Section Between STOP HERE ON RED SIGNS (FT)	Required Minimum Length of All-Red Clearance Interval (SEC)		
	15 MPH	20 MPH	25 MPH
1,000	45	34	27
950	43	32	26
900	41	31	25
850	39	29	23
800	36	27	22
750	34	26	20
700	32	24	19
650	30	22	18
600	27	20	16
550	25	19	15
500	23	17	14
450	20	15	12
400	18	14	11
350	16	12	10
300	14	10	8

Signal Face Visibility (See Note 7)	
Normal Speed Limit (MPH)	Minimum Visibility Distance (FT)
25	215
30	270
35	325
40	390
45	460
50	540
55	625

ALTERNATE TRAILER-MOUNTED PORTABLE TRAFFIC SIGNAL PLACEMENTS

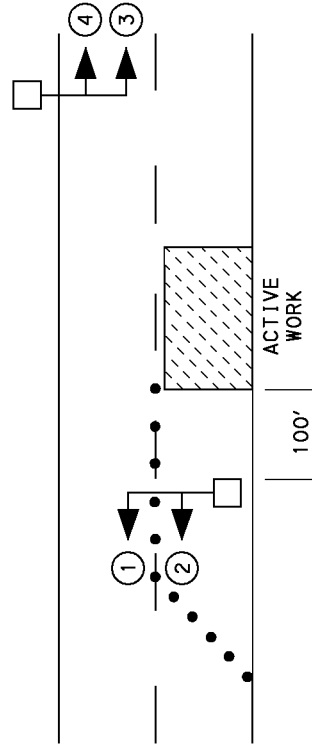

OPTION 1

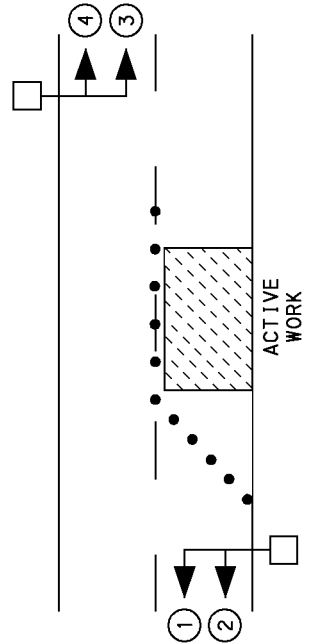

OPTION 2

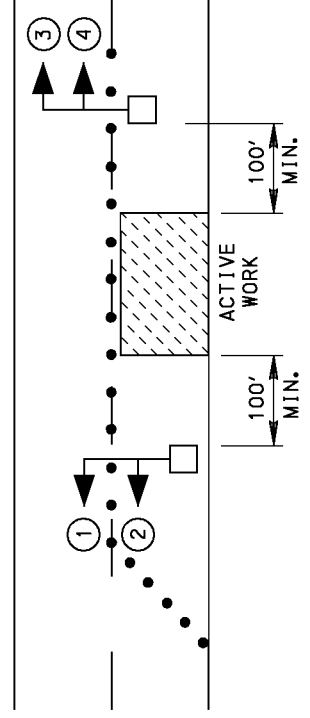

OPTION 3

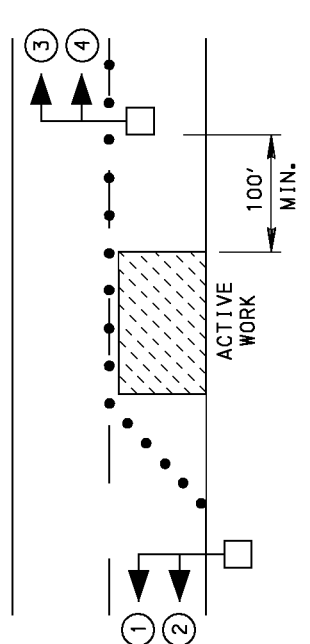

OPTION 4

PUBLICATION 213
SHORT-TERM STATIONARY OPERATION - TWO LANE, TWO-WAY ROADWAY
TEMPORARY TRAFFIC CONTROL SIGNALS - TRAILER-MOUNTED PORTABLE TRAFFIC CONTROL SIGNALS FOR COMPLEX CONDITIONS

NOTES

1. THE USE OF MANUALLY-CONTROLLED, TRAILER-MOUNTED PORTABLE TRAFFIC CONTROL SIGNALS IN PENNSYLVANIA FOR SHORT-TERM STATIONARY OPERATIONS WITH COMPLEX CONDITIONS SHALL COMPLY WITH PROVISIONS OF THIS FIGURE.
2. ADVANCE WRITTEN APPROVAL MUST BE OBTAINED FROM PENNDOT PRIOR TO USING PORTABLE TRAFFIC CONTROL SIGNALS FOR SHORT-TERM STATIONARY OPERATIONS ON ANY PUBLIC HIGHWAY EXCEPT FOR EMERGENCY WORK AS DEFINED IN PENNDOT PUBLICATION 213. A PENNDOT TEMPORARY TRAFFIC CONTROL SIGNAL PERMIT AND SITE-SPECIFIC DRAWING ARE REQUIRED FOR SHORT-TERM OPERATIONS WITH COMPLEX CONDITIONS, AND A COPY MUST BE MAINTAINED ON-SITE DURING THE PERIOD OF THE TEMPORARY TRAFFIC CONTROL SIGNAL USAGE.
3. REFER TO APPENDIX A OF THIS PUBLICATION FOR ADDITIONAL GUIDANCE AND ACCEPTANCE PROCEDURES PERTAINING TO PORTABLE TRAFFIC CONTROL SIGNALS.
4. THE DESIGN AND APPLICATION OF THE PORTABLE TRAFFIC CONTROL SIGNALS SHALL COMPLY WITH THE MOST CURRENT VERSION OF PENNDOT PUBLICATIONS 212, 213, AND 149.
5. SIGNAL SUPPORTS SHOULD BE A MINIMUM OF 2 FEET OFF THE EDGE OF TRAVEL WAY. IF THIS IS NOT POSSIBLE, THE SUPPORTS SHALL BE ADEQUATELY PROTECTED BY BARRIER, GUIDERAIL, OR CHANNELIZING DEVICES.
6. THE BOTTOM OF THE HOUSING OF A SIGNAL FACE SUSPENDED OVER THE ROADWAY SHALL BE A MINIMUM OF 15 FEET, BUT NOT MORE THAN 19 FEET ABOVE THE PAVEMENT. THE BOTTOM OF THE HOUSING OF A SIGNAL FACE THAT IS NOT MOUNTED OVER THE ROADWAY SHALL BE AT LEAST 8 FEET, BUT NOT MORE THAN 15 FEET ABOVE THE SIDEWALK OR, IF THERE IS NO SIDEWALK, ABOVE THE PAVEMENT GRADE AT THE CENTER OF THE ROADWAY.
7. A MINIMUM OF TWO SIGNAL FACES ON EACH APPROACH SHOULD BE CONTINUOUSLY VISIBLE TO APPROACHING TRAFFIC FROM A POINT MEETING THE SIGNAL VISIBILITY DISTANCES SPECIFIED IN THE TABLE ON SHEET 2 OF 3.
8. ALL SIGNALS LENSES SHALL BE 12 INCHES IN DIAMETER.
9. THE LENGTH OF YELLOW CHANGE INTERVALS IS NORMALLY IN THE RANGE FROM ABOUT 3 SECONDS TO 6 SECONDS. USE A 5-SECOND YELLOW CHANGE INTERVAL, OR AN APPROPRIATE ALTERNATE VALUE FROM PENNDOT PUBLICATION 149M BASED ON ACTUAL SITE CONDITIONS.
10. AN ALL-RED CLEARANCE INTERVAL MUST BE USED. THE LENGTH OF THE ALL-RED CLEARANCE INTERVAL IS BASED ON THE LENGTH OF THE ONE-LANE TWO-WAY TRAFFIC SECTION CONTROLLED BY THE PORTABLE TRAFFIC CONTROL SIGNALS AND THE SPEED OF TRAFFIC THROUGH THAT SECTION. MONITOR TRAFFIC OPERATIONS DURING THE PERIOD OF PORTABLE TRAFFIC CONTROL SIGNAL USAGE AND ADJUST THE LENGTH OF THE ALL-RED CLEARANCE INTERVAL TO ACCOUNT FOR SITE CONDITIONS AND TO PROVIDE FOR SAFE AND EFFICIENT TRAFFIC OPERATIONS. UNLESS OTHERWISE INDICATED BY PENNDOT, THE MINIMUM LENGTH OF ALL-RED CLEARANCE INTERVALS SHALL BE AS INDICATED ON THE TABLE ON SHEET 2 OF 3.
11. FOR FIXED TIME AND ACTUATED OPERATION, THE MINIMUM GREEN INTERVAL PROVIDED FOR EACH APPROACH SHALL BE 10 SECONDS, UNLESS OTHERWISE INDICATED BY PENNDOT. THE LENGTH OF GREEN INTERVALS SHOULD BE SUCH AS TO PROVIDE FOR SAFE AND EFFICIENT TRAFFIC OPERATIONS. USE GREEN INTERVALS AS INDICATED ON THE PERMIT DRAWING. MONITOR TRAFFIC OPERATIONS AS TRAFFIC VOLUMES CHANGE THROUGHOUT THE PERIOD OF PORTABLE TRAFFIC CONTROL SIGNAL USAGE AND ADJUST GREEN INTERVALS TO PROVIDE FOR SAFE AND EFFICIENT TRAFFIC OPERATIONS.
12. WHEN NOT IN OPERATION, SIGNAL HEADS SHALL BE REMOVED FROM THE VIEW OF TRAFFIC OR HOODED WITH A MATERIAL THAT COVERS THE SIGNAL INDICATIONS FROM THE VIEW OF TRAFFIC. ALL INAPPROPRIATE SIGNS SHALL ALSO BE REMOVED, COVERED, FOLDED, OR TURNED SO THAT THEY ARE NOT READABLE BY ONCOMING TRAFFIC WHEN THE PORTABLE TRAFFIC CONTROL SIGNAL IS NOT IN OPERATION.
13. WHEN THE TEMPORARY TRAFFIC CONTROL SIGNAL IS CHANGED TO FLASHING MODE, EITHER MANUALLY OR AUTOMATICALLY, RED SIGNAL INDICATIONS SHALL BE FLASHED TO BOTH APPROACHES.
14. SIGNAL MODULES MUST BE REPLACED IN ACCORDANCE WITH THE MANUFACTURERS RECOMMENDATIONS, AND A RECORD OF THIS MUST BE MAINTAINED BY THE USER.
15. ADDITIONAL SIGNS AND DEVICES SHALL BE INSTALLED AS REQUIRED IN PENNDOT PUBLICATIONS 212 AND 213, AND AS REQUIRED BASED ON ACTUAL SITE CONDITIONS.
16. PENNDOT RESERVES THE RIGHT TO INSPECT EACH PORTABLE TRAFFIC CONTROL SIGNAL USAGE. PENNDOT ALSO RESERVES THE RIGHT TO REVOKE A TEMPORARY TRAFFIC CONTROL SIGNAL PERMIT OR TO SUSPEND THE OPERATION OF THE PORTABLE TRAFFIC CONTROL SIGNAL IF THE USER SHALL AT ANY TIME WILLFULLY OR NEGLIGENTLY FAIL TO COMPLY WITH THE CONDITIONS CONTAINED IN THE PERMIT OR PUBLICATION 213, OR FAIL TO MAKE ANY CHANGES IN THE OPERATION OF THE SIGNAL, OR REMOVE IT, WHEN SO ORDERED BY PENNDOT. THE USER SHALL NOT MAKE ANY CHANGE IN THE OPERATION OF THE PORTABLE TRAFFIC CONTROL SIGNAL AS DEFINED IN THE PERMIT DRAWINGS WITHOUT PRIOR WRITTEN APPROVAL OF PENNDOT.

PUBLICATION 213
LONG-TERM STATIONARY OPERATION - TWO-LANE, TWO-WAY ROADWAY
TEMPORARY TRAFFIC CONTROL SIGNALS USING FIXED SUPPORTS

NOTES

1. THE USE OF TEMPORARY TRAFFIC CONTROL SIGNALS ON FIXED SUPPORTS IN PENNSYLVANIA FOR LONG-TERM STATIONARY OPERATIONS SHALL COMPLY WITH THE PROVISIONS OF THIS FIGURE.
2. REFER TO APPENDIX A OF THIS PUBLICATION FOR ADDITIONAL GUIDANCE AND ACCEPTANCE PROCEDURES PERTAINING TO TEMPORARY TRAFFIC CONTROL SIGNALS ON FIXED SUPPORTS.
3. THE DESIGN AND APPLICATION OF THE TEMPORARY TRAFFIC CONTROL SIGNALS ON FIXED SUPPORTS SHALL COMPLY WITH THE MOST CURRENT VERSION OF PENNDOT PUBLICATIONS 212, 213, AND 149.
4. REMOVE CONFLICTING PAVEMENT MARKINGS.
5. STOP BARS SHALL BE INSTALLED WITH TEMPORARY TRAFFIC CONTROL SIGNALS ON FIXED SUPPORTS FOR LONG-TERM STATIONARY OPERATIONS. EXISTING CONFLICTING PAVEMENT MARKINGS AND RAISED PAVEMENT MARKERS BETWEEN STOP BARS SHALL BE REMOVED. AFTER TEMPORARY TRAFFIC CONTROL SIGNALS ARE REMOVED, THE STOP BARS SHALL BE REMOVED AND THE PERMANENT PAVEMENT MARKINGS RESTORED.
6. ADVANCE WRITTEN APPROVAL MUST BE OBTAINED FROM PENNDOT PRIOR TO USING TEMPORARY TRAFFIC CONTROL SIGNALS ON FIXED SUPPORTS FOR LONG-TERM STATIONARY OPERATIONS ON ANY PUBLIC HIGHWAY. A PENNDOT TEMPORARY TRAFFIC CONTROL SIGNAL PERMIT AND SITE-SPECIFIC DRAWING ARE REQUIRED FOR LONG-TERM OPERATIONS, AND A COPY MUST BE MAINTAINED ON-SITE DURING THE PERIOD OF THE TEMPORARY TRAFFIC CONTROL SIGNAL USAGE.
7. ALL SIGNAL LENSES SHALL BE 12 INCHES IN DIAMETER.
8. THE LOCAL POLICE DEPARTMENT MUST BE PROVIDED WITH THE NAME AND TELEPHONE NUMBER OF AN EMERGENCY CONTACT PERSON WHO IS AVAILABLE 24 HOURS PER DAY, 7 DAYS A WEEK DURING THE PERIOD OF TEMPORARY TRAFFIC CONTROL SIGNAL USAGE.
9. A MINIMUM OF TWO SIGNAL FACES ON EACH APPROACH SHOULD BE CONTINUOUSLY VISIBLE TO APPROACHING TRAFFIC FROM A POINT MEETING THE MINIMUM SIGNAL FACE VISIBILITY DISTANCES SPECIFIED ON THIS FIGURE.
10. SIGNAL SUPPORTS SHOULD BE A MINIMUM OF 2 FEET OFF THE EDGE OF TRAVEL WAY. IF THIS IS NOT POSSIBLE, THE SUPPORTS SHALL BE ADEQUATELY PROTECTED BY BARRIER, GUIDE RAIL, OR CHANNELIZING DEVICES.
11. THE BOTTOM OF THE HOUSING OF A SIGNAL FACE SUSPENDED OVER THE ROADWAY SHALL BE A MINIMUM OF 15 FEET, BUT NOT MORE THAN 19 FEET, ABOVE THE PAVEMENT. THE BOTTOM OF THE HOUSING OF A SIGNAL FACE THAT IS NOT MOUNTED OVER THE ROADWAY SHALL BE AT LEAST 8 FEET, BUT NOT MORE THAN 15 FEET ABOVE THE SIDEWALK OR, IF THERE IS NO SIDEWALK, ABOVE THE PAVEMENT GRADE AT THE CENTER OF THE ROADWAY.
12. ADDITIONAL SIGNS AND DEVICES SHALL BE INSTALLED AS REQUIRED IN PENNDOT PUBLICATIONS 212 AND 213, AND AS REQUIRED BASED ON ACTUAL SITE CONDITIONS.
13. SIGNAL MODULES MUST BE REPLACED IN ACCORDANCE WITH THE MANUFACTURER'S RECOMMENDATIONS, AND A RECORD OF THIS MUST BE MAINTAINED BY THE USER.
14. WHEN NOT IN OPERATION, SIGNAL HEADS SHALL BE REMOVED FROM THE VIEW OF TRAFFIC OR HOODED WITH A MATERIAL THAT COVERS THE SIGNAL INDICATIONS FROM THE VIEW OF TRAFFIC. ALL INAPPROPRIATE SIGNS SHALL ALSO BE REMOVED COVERED, FOLDED, OR TURNED SO THAT THEY ARE NOT READABLE BY ONCOMING TRAFFIC WHEN THE TEMPORARY TRAFFIC CONTROL SIGNAL IS NOT IN OPERATION.
15. PENNDOT RESERVES THE RIGHT TO INSPECT EACH TEMPORARY TRAFFIC CONTROL SIGNAL USAGE. PENNDOT ALSO RESERVES THE RIGHT TO REVOKE A TEMPORARY TRAFFIC CONTROL SIGNAL PERMIT OR TO SUSPEND THE OPERATION OF THE TEMPORARY TRAFFIC CONTROL SIGNAL IF THE USER SHALL AT ANY TIME WILLFULLY OR NEGLIGENTLY FAIL TO COMPLY WITH THE CONDITIONS CONTAINED IN THE PERMIT OR PUBLICATION 213, OR FAIL TO MAKE ANY CHANGES IN THE OPERATION OF THE SIGNAL, OR TO REMOVE IT, WHEN SO ORDERED BY PENNDOT. THE USER SHALL NOT MAKE ANY CHANGE IN THE OPERATION OF THE TEMPORARY TRAFFIC CONTROL SIGNAL AS DEFINED IN THE PERMIT DRAWINGS WITHOUT PRIOR WRITTEN APPROVAL OF PENNDOT.
16. WHEN THE TEMPORARY TRAFFIC CONTROL SIGNAL IS CHANGED TO FLASHING MODE, EITHER MANUALLY OR AUTOMATICALLY, RED SIGNAL INDICATIONS SHALL BE FLASHED TO BOTH APPROACHES.

PUBLICATION 213
LONG-TERM STATIONARY OPERATION - TWO-LANE, TWO-WAY ROADWAY
TEMPORARY TRAFFIC CONTROL SIGNALS USING TRAILER-MOUNTED PORTABLE TRAFFIC CONTROL SIGNALS

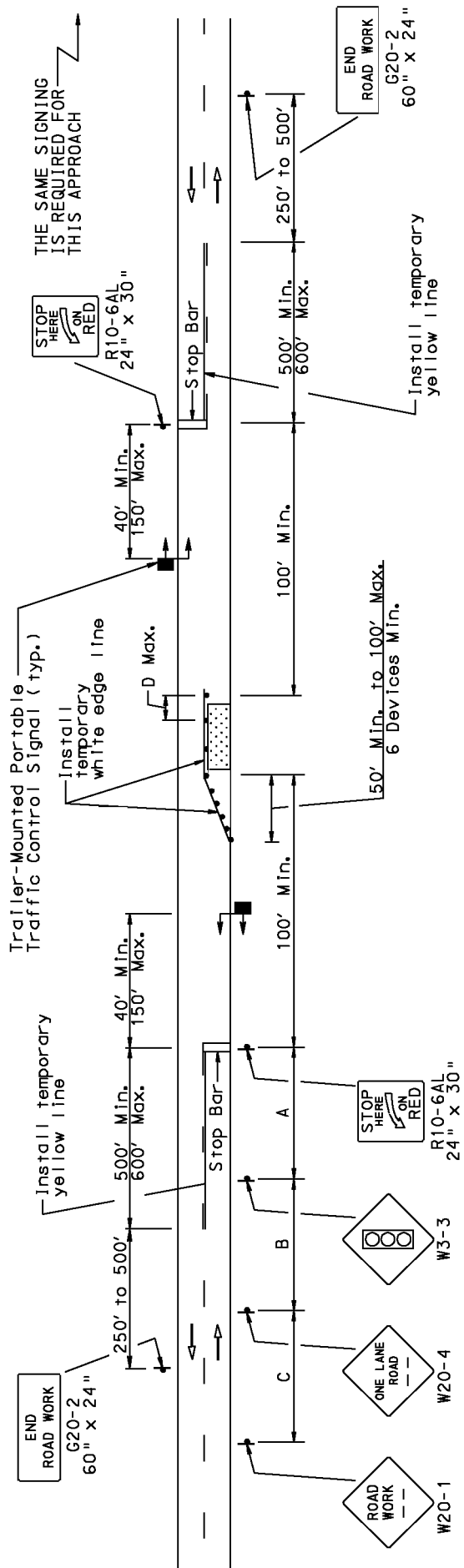

THE SAME SIGNING IS REQUIRED FOR THIS APPROACH

NOTE
Refer to Sheet 2 of 3 for Alternate Trailer-Mounted Portable Traffic Signal Placement.

Signal Face Visibility (See Note 1)	
Normal Speed Limit (MPH)	Minimum Visibility Distance (FT)
25	215
30	270
35	325
40	390
45	460
50	540
55	625

Distance plaques on Advance Warning signs

shall be the same series type.

Example: either all XXX ft. or all "AHEAD"

CONDITION 1: All Highways (except Freeways and Expressways)

- A = 500 ft.
- B = 500 ft., W20-4 sign distance plaque to read 1000 ft.
- C = 500 ft., W20-1 sign distance plaque to read 1500 ft.
- D = 2 times the normal speed limit

CONDITION 2: For Urban Streets

- A, B and C = 200 ft. and sign distance plaque to read "AHEAD"
- D = 2 times the normal speed limit

ALTERNATE TRAILER-MOUNTED PORTABLE TRAFFIC SIGNAL PLACEMENTS

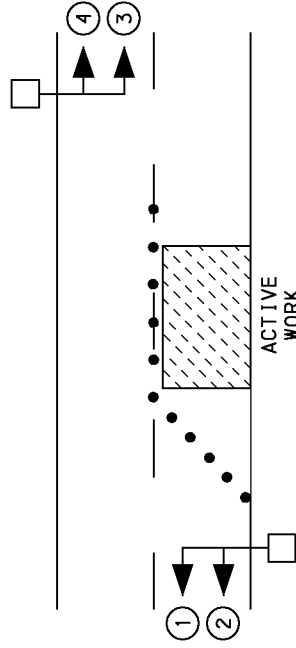

OPTION 1

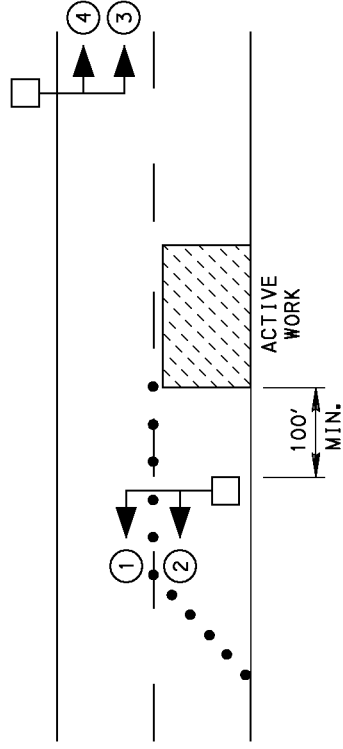

OPTION 2

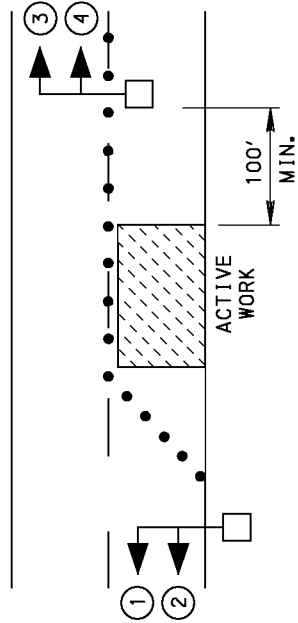

OPTION 3

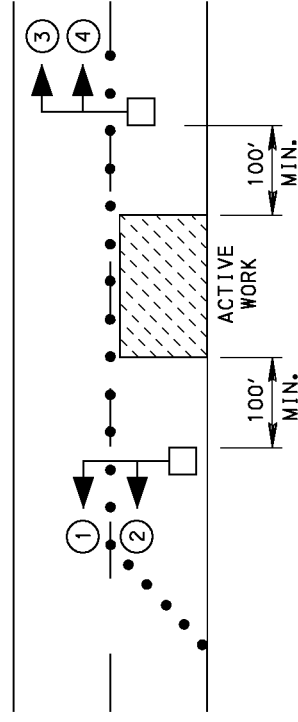

OPTION 4

PUBLICATION 213
LONG-TERM STATIONARY OPERATION - TWO-LANE, TWO-WAY ROADWAY
TEMPORARY TRAFFIC CONTROL SIGNALS USING TRAILER-MOUNTED PORTABLE TRAFFIC CONTROL SIGNALS

NOTES

1. THE USE OF PORTABLE TRAFFIC CONTROL SIGNALS IN PENNSYLVANIA FOR LONG-TERM STATIONARY OPERATIONS SHALL COMPLY WITH THE PROVISIONS OF THIS FIGURE.
2. REFER TO APPENDIX A OF THIS PUBLICATION FOR ADDITIONAL GUIDANCE AND ACCEPTANCE PROCEDURES PERTAINING TO PORTABLE TRAFFIC CONTROL SIGNALS.
3. THE DESIGN AND APPLICATION OF THE PORTABLE TRAFFIC CONTROL SIGNALS SHALL COMPLY WITH THE MOST CURRENT VERSION OF PENNDOT PUBLICATIONS 212, 213, AND 149.
4. REMOVE CONFLICTING PAVEMENT MARKINGS.
5. STOP BARS SHALL BE INSTALLED WITH PORTABLE TRAFFIC CONTROL SIGNALS FOR LONG-TERM STATIONARY OPERATIONS. EXISTING CONFLICTING PAVEMENT MARKINGS AND RAISED PAVEMENT MARKERS BETWEEN STOP BARS SHALL BE REMOVED AFTER PORTABLE TRAFFIC CONTROL SIGNALS ARE REMOVED, THE STOP BARS SHALL BE REMOVED AND THE PERMANENT PAVEMENT MARKINGS RESTORED.
6. ADVANCE WRITTEN APPROVAL MUST BE OBTAINED FROM PENNDOT PRIOR TO USING PORTABLE TRAFFIC CONTROL SIGNALS FOR LONG-TERM STATIONARY OPERATIONS ON ANY PUBLIC HIGHWAY. A PENNDOT TEMPORARY TRAFFIC CONTROL SIGNAL PERMIT AND SITE-SPECIFIC DRAWING ARE REQUIRED FOR LONG-TERM OPERATIONS, AND A COPY MUST BE MAINTAINED ON-SITE DURING THE PERIOD OF THE TEMPORARY TRAFFIC CONTROL SIGNAL USAGE.
7. PORTABLE TRAFFIC CONTROL SIGNALS USED FOR LONG-TERM STATIONARY OPERATIONS SHALL BE TRAILER-MOUNTED UNITS HAVING AT LEAST ONE SIGNAL HEAD ON A MAST ARM OVER THE ROADWAY. PEDESTAL-MOUNTED PORTABLE TRAFFIC CONTROL SIGNAL UNITS ARE NOT PERMITTED FOR LONG-TERM OPERATIONS.
8. ALL SIGNAL LENSES SHALL BE 12 INCHES IN DIAMETER.
9. THE LOCAL POLICE DEPARTMENT MUST BE PROVIDED WITH THE NAME AND TELEPHONE NUMBER OF AN EMERGENCY CONTACT PERSON WHO IS AVAILABLE 24 HOURS PER DAY, 7 DAYS A WEEK DURING THE PERIOD OF PORTABLE TRAFFIC CONTROL SIGNAL USAGE.
10. ALL PORTABLE TRAFFIC CONTROL SIGNAL UNITS USED FOR LONG-TERM STATIONARY OPERATIONS MUST BE INTERCONNECTED VIA RADIO OR HARD WIRE TO ENSURE FAIL-SAFE OPERATION AND PROPER FUNCTIONING.
11. A MINIMUM OF TWO SIGNAL FACES ON EACH APPROACH SHOULD BE CONTINUOUSLY VISIBLE TO APPROACHING TRAFFIC FROM A POINT MEETING THE MINIMUM SIGNAL FACE VISIBILITY DISTANCES SPECIFIED ON THIS FIGURE.
12. SIGNAL SUPPORTS SHOULD BE A MINIMUM OF 2 FEET OFF THE EDGE OF TRAVEL WAY. IF THIS IS NOT POSSIBLE, THE SUPPORTS SHALL BE ADEQUATELY PROTECTED BY BARRIER, GUIDE RAIL, OR CHANNELIZING DEVICES.
13. THE BOTTOM OF THE HOUSING OF A SIGNAL FACE SUSPENDED OVER THE ROADWAY SHALL BE A MINIMUM OF 15 FEET, BUT NOT MORE THAN 19 FEET, ABOVE THE PAVEMENT. THE BOTTOM OF THE HOUSING OF A SIGNAL FACE THAT IS NOT MOUNTED OVER THE ROADWAY SHALL BE AT LEAST 8 FEET, BUT NOT MORE THAN 15 FEET ABOVE THE SIDEWALK OR, IF THERE IS NO SIDEWALK, ABOVE THE PAVEMENT GRADE AT THE CENTER OF THE ROADWAY.
14. ADDITIONAL SIGNS AND DEVICES SHALL BE INSTALLED AS REQUIRED IN PENNDOT PUBLICATIONS 212 AND 213, AND AS REQUIRED BASED ON ACTUAL SITE CONDITIONS.
15. SIGNAL MODULES MUST BE REPLACED IN ACCORDANCE WITH THE MANUFACTURER'S RECOMMENDATIONS, AND A RECORD OF THIS MUST BE MAINTAINED BY THE USER.
16. WHEN NOT IN OPERATION, SIGNAL HEADS SHALL BE REMOVED FROM THE VIEW OF TRAFFIC OR HOODED WITH A MATERIAL THAT COVERS THE SIGNAL INDICATIONS FROM THE VIEW OF TRAFFIC. ALL INAPPROPRIATE SIGNS SHALL ALSO BE REMOVED, COVERED, FOLDED, OR TURNED SO THAT THEY ARE NOT READABLE BY ONCOMING TRAFFIC WHEN THE PORTABLE TRAFFIC CONTROL SIGNAL IS NOT IN OPERATION.
17. PENNDOT RESERVES THE RIGHT TO INSPECT EACH PORTABLE TRAFFIC CONTROL SIGNAL USAGE. PENNDOT ALSO RESERVES THE RIGHT TO REVOKE A TEMPORARY TRAFFIC CONTROL SIGNAL PERMIT OR TO SUSPEND THE OPERATION OF THE PORTABLE TRAFFIC CONTROL SIGNAL IF THE USER SHALL AT ANY TIME WILLFULLY OR NEGLIGENTLY FAIL TO COMPLY WITH THE CONDITIONS CONTAINED IN THE PERMIT OR PUBLICATION 213, OR FAIL TO MAKE ANY CHANGES IN THE OPERATION OF THE SIGNAL, OR TO REMOVE IT, WHEN SO ORDERED BY PENNDOT. THE USER SHALL NOT MAKE ANY CHANGE IN THE OPERATION OF THE PORTABLE TRAFFIC CONTROL SIGNAL AS DEFINED IN THE PERMIT DRAWINGS WITHOUT PRIOR WRITTEN APPROVAL OF PENNDOT.
18. STEPS MUST BE TAKEN TO ENSURE CONTINUED PROPER PLACEMENT AND TO FORESTALL POSSIBLE VANDALISM OF THE PORTABLE TRAFFIC CONTROL SIGNAL UNITS. TIRES AND THE "HITCH" MUST BE REMOVED FROM THE TRAILER, AND BATTERY ENCLOSURES, CRANK MECHANISMS FOR HORIZONTAL ARMS, AND OTHER MECHANISMS TO ADJUST PLACEMENT OR OPERATION MUST BE LOCKED TO ELIMINATE ANY TAMPERING BY UNAUTHORIZED PERSONNEL.
19. WHEN THE TEMPORARY TRAFFIC CONTROL SIGNAL IS CHANGED TO FLASHING MODE, EITHER MANUALLY OR AUTOMATICALLY, RED SIGNAL INDICATIONS SHALL BE FLASHED TO BOTH APPROACHES.

PATA
26e PL

PUBLICATION 213
 LONG-TERM STATIONARY OPERATION
 TWO-LANE, TWO-WAY ROADWAY - TEMPORARY ROADWAY

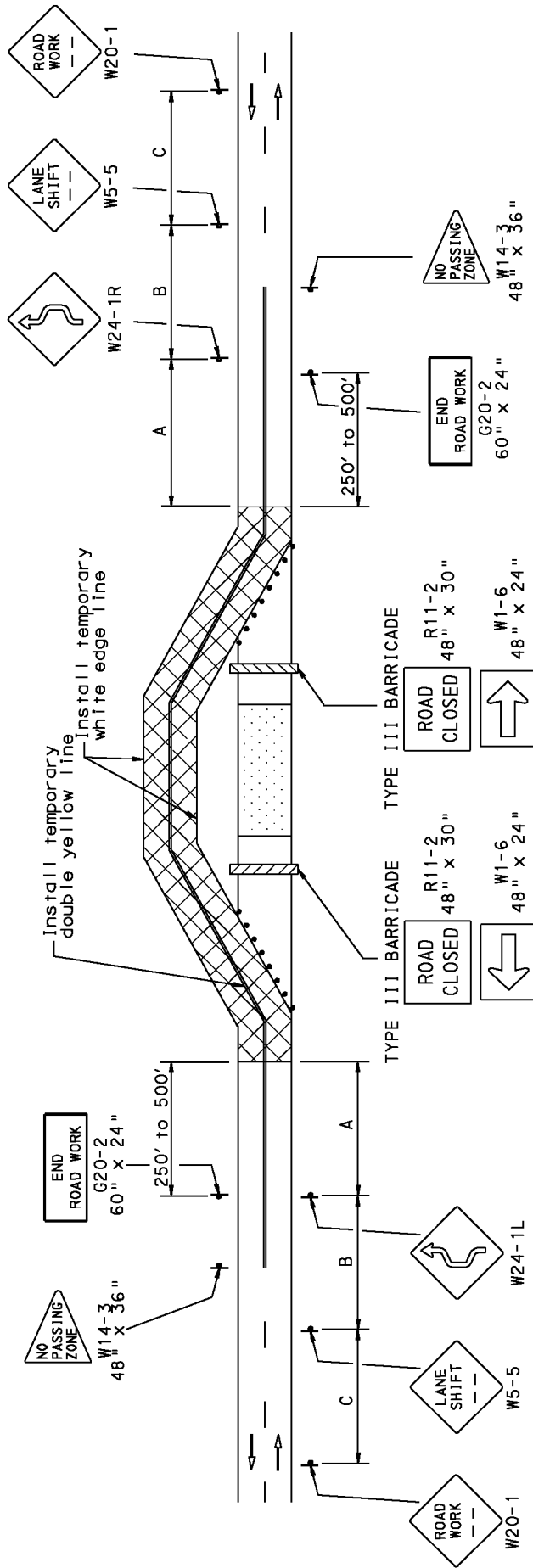

Distance plaques on Advance Warning signs shall be the same series type.

Example: either all XXX ft. or all "AHEAD"
 CONDITION 1: All Highways (except Freeways and Expressways)
 A = 500 ft.
 B = 1000 ft., W5-5 sign distance plaque to read 1500 ft.
 C = 1640 ft., W20-1 sign distance plaque to read 1/2 Mile

CONDITION 2: For Urban Streets
 A, B and C = 200 ft. and sign distance plaque to read "AHEAD"

LEGEND

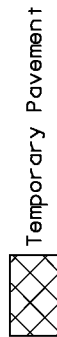

NOTES

1. Remove conflicting pavement markings.
2. All temporary barriers and end treatments shall be crashworthy.
3. A no passing zone shall be established when an existing no passing zone is not present.
4. If the tangent distance along the temporary diversion is more than 600 ft, an appropriate Reverse Curve Sign (W1-4L or W1-4R) should be used in place of the W24-1L or W24-1R, and a second Reverse Curve Sign (opposite of the first) should be used in advance of the second reverse curve back to the original alignment.
5. When the tangent section of the diversion is more than 600 ft, and the diversion has sharp curves with recommended speeds of 30 MPH or less, Reverse Turn Signs (W1-3L or W1-3R) should be used in lieu of the Reverse Curve Signs (W1-4L or W1-4R) respectively.
6. Where the temporary pavement and old pavement are different colors, the temporary pavement should start on the tangent of the existing pavement and end on the tangent of the existing pavement.
7. Delineators should be placed along the temporary roadway where needed.

PUBLICATION 213
 LONG-TERM STATIONARY OPERATION
 THREE-LANE, TWO-WAY ROADWAY WITH PASSING - WORK AREA IN THE SINGLE LANE APPROACH

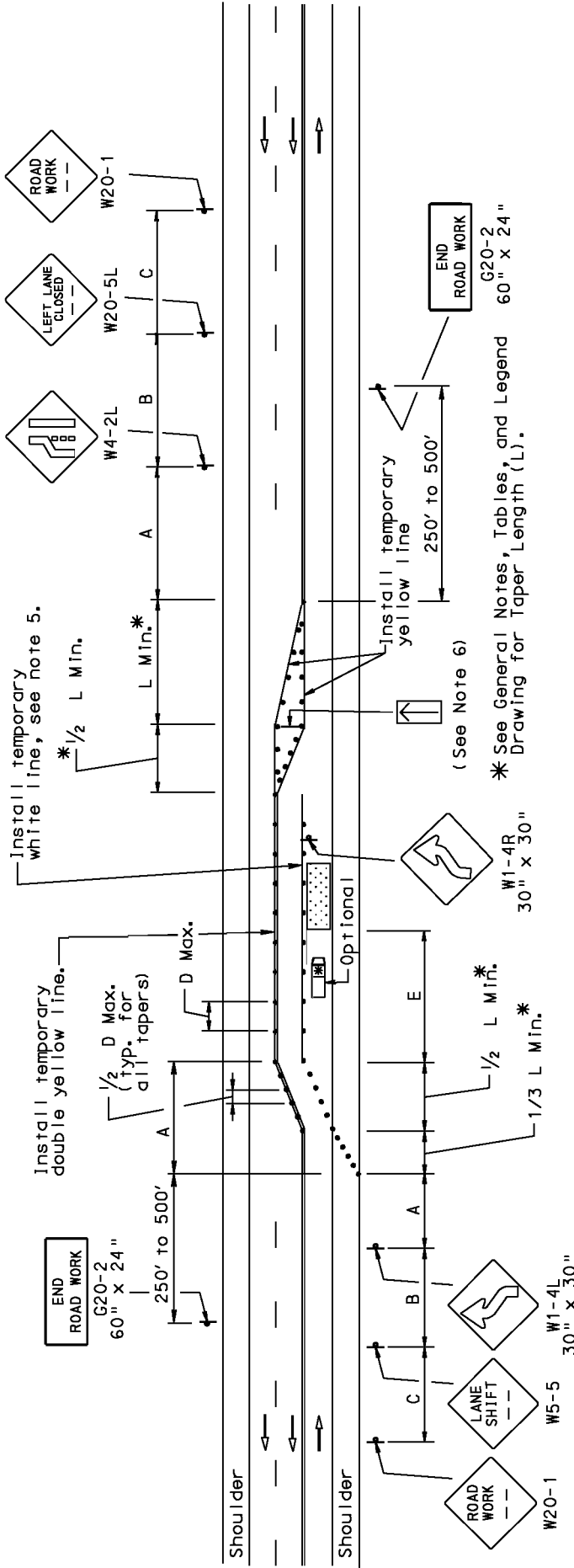

Distance plaques on Advance Warning signs shall be the same series type.
 Example: either all XXX ft. or all "AHEAD"
 CONDITION 1: All Highways (except freeways and expressways):
 A = 500 ft., W1-4L and W4-2L
 B = 500 ft., W5-5 and W20-5L sign distance plaque to read 1000 ft.
 C = 500 ft., W20-1 sign distance plaque to read 1500 ft.
 CONDITION 2: For Urban Streets
 A, B and C = 200 ft. and sign distance plaque to read "AHEAD"

NOTES

1. Remove conflicting pavement markings.
2. When paved shoulders having a width of 8 ft or more are closed, channelizing devices should be used to close the shoulder in advance of the shifting taper.
3. When a highway-rail grade crossing exists within the work zone, or it is anticipated that queues resulting from the lane closure might extend through a highway-rail grade crossing, provisions shall be made to eliminate conflicts, which may require placing a flagger at the crossing. Coordination with the railroad is essential.
4. Where speed or volume is higher, signing such as additional Left Lane Closed XX ft Sign (W20-5L) or Be Prepared to Stop Sign (W3-4) should be used in advance of the W20-1 sign. shall be 1/2 D Max.
5. Where channelizing devices are used instead of pavement markings for edge lines, the spacing shall be 1/2 D Max.
6. See PATA GENERAL, Table 5 for size of the Flashing Arrow Panel.

PATA
 28

PUBLICATION 213
 LONG-TERM STATIONARY OPERATION - THREE-LANE, TWO-WAY ROADWAY WITH CENTER LANE, LEFT TURN ONLY PATTERN
 WORK AREA IN ONE OF THE THROUGH LANES

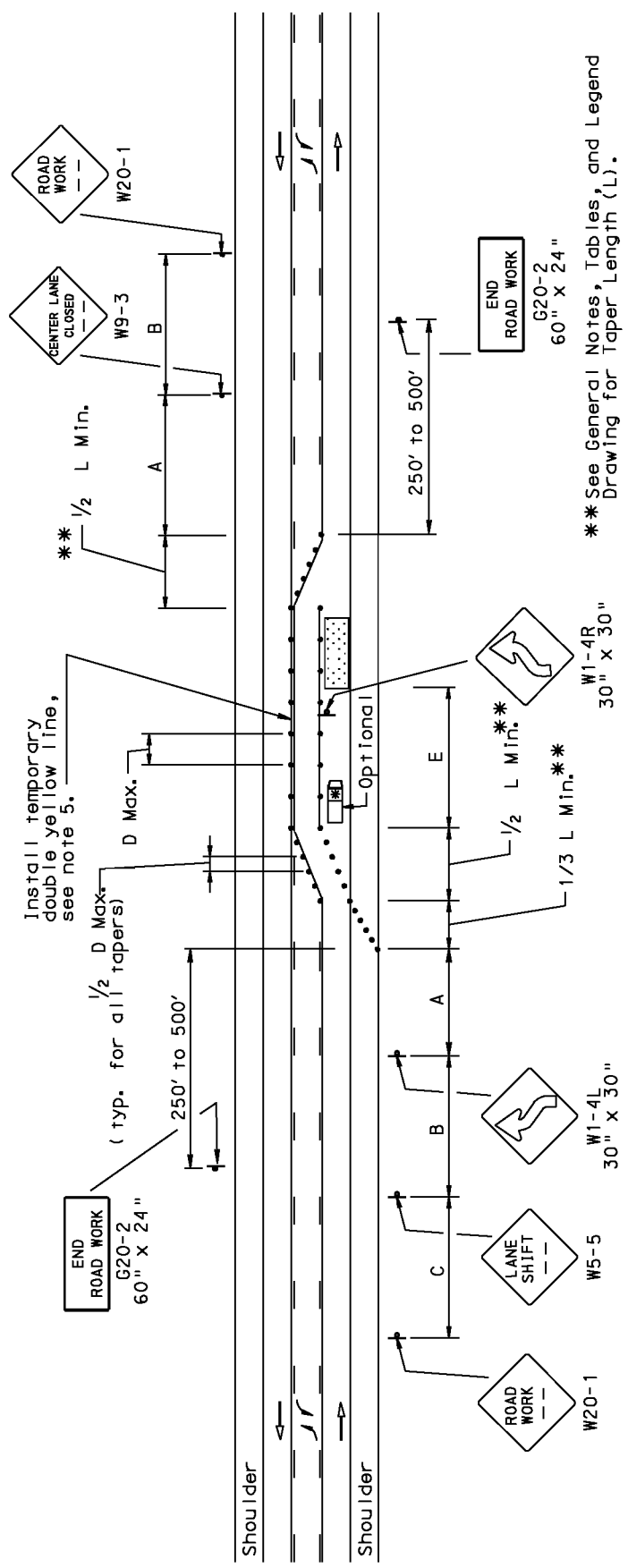

** See General Notes, Tables, and Legend Drawing for Taper Length (L).

W1-4R
 30" x 30"

W1-4L
 30" x 30"

W5-5
 LANE SHIFT

W20-1
 ROAD WORK

G20-2
 END ROAD WORK
 60" x 24"

Distance plaques on Advance Warning signs shall be the same series type.
 Example: either all XXX ft. or all "AHEAD"

All Highways (except freeway and expressway)	E *	
	D	ft
25	50	155
30	60	200
35	70	250
40	80	305
45	90	360
50	100	425
55	110	495

*Distances may be increased for downgrades or other conditions that affect stopping sight distance.

CONDITION 1: All Highways (except freeways and expressways):
 A = 500 ft., W9-3 sign distance plaque to read 500 ft.
 B = 500 ft., W20-1 and W5-5 sign distance plaque to read 1000 ft.
 C = 500 ft., W20-1 sign distance plaque to read 1500 ft.

CONDITION 2: For Urban Streets
 A, B and C = 200 ft. and sign distance plaque to read "AHEAD"

NOTES

1. Remove conflicting pavement markings.
2. When paved shoulders having a width of 8 ft or more are closed, channelizing devices should be used to close the shoulder in advance of the shifting taper.
3. When a highway-rail grade crossing exists within the work zone, or it is anticipated that queues resulting from the lane closure might extend through a highway-rail grade crossing, provisions shall be made to eliminate conflicts, which may require placing a flagger at the crossing. Coordination with the railroad is essential.
4. Where speed or volume is higher, signing such as additional Center Lane Closed XX ft Sign (W9-3) or Be Prepared to Stop Sign (W3-4) should be used in advance of the W20-1 sign.
5. Where channelizing devices are used instead of pavement markings for edge lines, the spacing shall be 1/2 D Max.

PUBLICATION 213
 LONG-TERM STATIONARY OPERATION
 WORK AREA IN A TWO-WAY LEFT TURN LANE

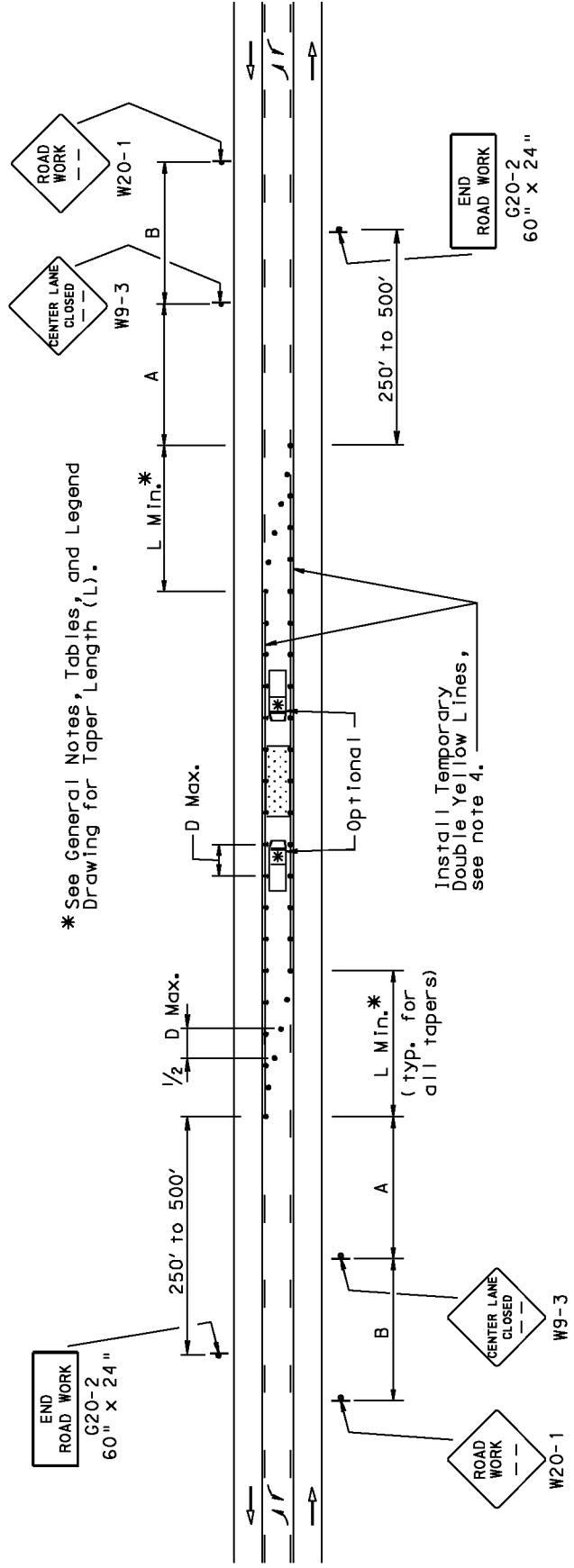

Distance plaques on Advance Warning signs shall be the same series type.

Example: either all XXX ft. or all "AHEAD"

CONDITION 1: All Highways (except Freeways and Expressways)
 A = 500 ft., W9-3 sign distance plaque to read 500 ft.
 B = 500 ft., W20-1 sign distance plaque to read 1000 ft.
 D = 2 times the normal speed limit

CONDITION 2: For Urban Streets
 A and B = 200 ft. and sign distance plaque to read "AHEAD"
 D = 2 times the normal speed limit

NOTES

1. Remove conflicting pavement markings.
2. When a highway-rail grade crossing exists within the work zone, or it is anticipated that queues resulting from the lane closure might extend through a highway-rail grade crossing, provisions shall be made to eliminate conflicts, which may require placing a flagger at the crossing. Coordination with the railroad is essential.
3. Where speed or volume is higher, signing such as additional Center Lane Closed XX ft Sign (W9-3) or Be Prepared To Stop Sign (W3-4) should be used in advance of the W20-1 sign.
4. Where channelizing devices are used instead of pavement markings for edge lines, the spacing shall be 1/2 D Max.

PATA
 30

**BLANK
PAGE**

PUBLICATION 213
LONG-TERM STATIONARY OPERATION - MULTILANE, UNDIVIDED HIGHWAY
WORK AREA IN THE LEFT OR RIGHT LANE

** See General Notes, Tables, and Legend Drawing for Taper Length (L).
*** Speeds less than 45 MPH (Optional)

Required on Expressways when workers are present, but Optional for All Other Highways, see note 7.

SIGNING FOR THIS APPROACH SHALL COMPLY WITH PATA 24.

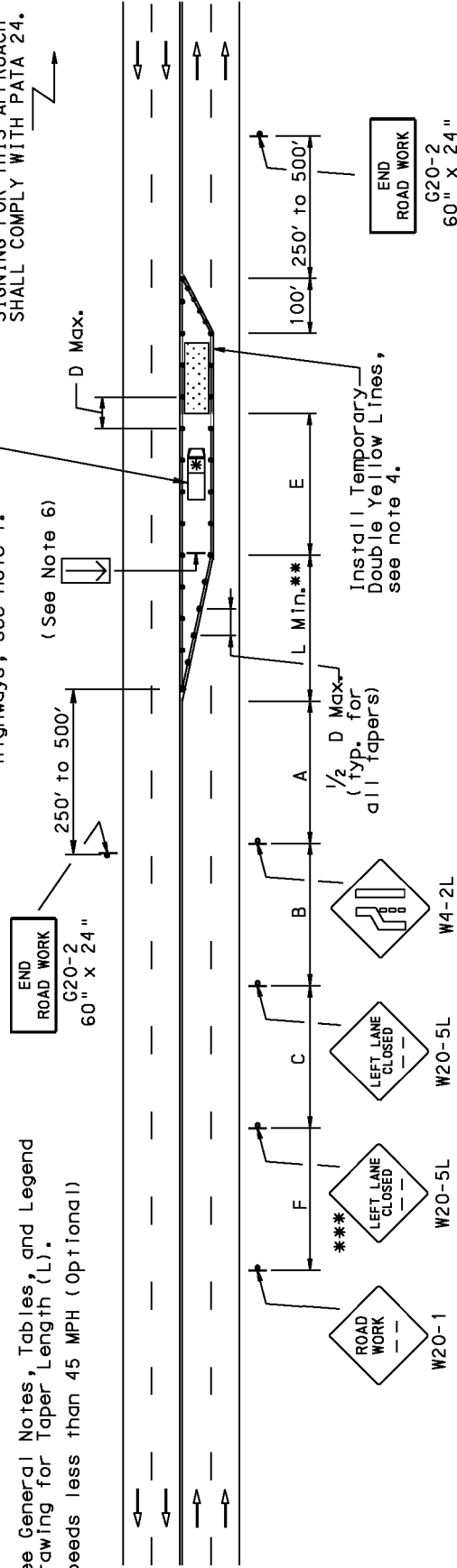

Distance plaques on Advance Warning signs shall be the same series type.

Example: either all XXX ft. or all "AHEAD"

CONDITION 1: All Highways (except Freeways and Expressways)

- A = 500 ft.
- B = 500 ft., W20-5L sign distance plaque to read 1000 ft.
- C = 500 ft., W20-5L sign distance plaque to read 1500 ft.
- (Distance C and the second W20-5L sign may be eliminated if speeds are less than 45 MPH)
- F = 1140 ft. or (1640 ft. if second W20-5L sign is eliminated, W20-1 sign distance plaque to read 1/2 MILE)

CONDITION 2: For Urban Streets

- A, B and F = 200 ft. and sign distance plaque to read "AHEAD"
- (Distance C and the second W20-5L sign may be eliminated)

CONDITION 3: For Freeway and Expressway Highways

- A = 1000 ft.
- B = 1640 ft., W20-5L sign distance plaque to read 1/2 MILE
- C = 2640 ft., W20-5L sign distance plaque to read 1 MILE
- F = 5280 ft., W20-1 sign distance plaque to read 2 MILES

All Highways (except freeway and expressway)		E*
MPH	D ft	f t
25	50	155
30	60	200
35	70	250
40	80	305
45	90	360
50	100	425
55	110	495

*Distances may be increased for downgrades or other conditions that affect stopping sight distance.

PATA
31

SHEET 1 OF 2
(SEE SHEET 2 OF 2 FOR NOTES)

PUBLICATION 213
LONG-TERM STATIONARY OPERATION - MULTILANE, UNDIVIDED HIGHWAY
WORK AREA IN THE LEFT OR RIGHT LANE

NOTES

1. Remove conflicting pavement markings.
2. When a highway-rail grade crossing exists within the work zone, or it is anticipated that queues resulting from the lane closure might extend through a highway-rail grade crossing, provisions shall be made to eliminate conflicts, which may require placing a flagger at the crossing. Coordination with the railroad is essential.
3. Where speed or volume is higher, signing such as additional Left Lane Closed XX ft Sign (W20-5L) or Be Prepared To Stop Sign (W3-4) should be used in advance of the W20-1 sign.
4. Where channelizing devices are used instead of pavement markings for edge lines, the spacing shall be $\frac{1}{2}$ D Max.
5. For right lane closures, signing is not required for the opposite approach. Right Lane Closed Signs (W20-5R) shall be used instead of the Left Lane Closed Signs (W20-5L), and Pavement Width Transition - Right Lane Ends Signs (W4-2R) shall be used instead of Pavement Width Transition - Left Lane Ends Signs (W4-2L).
6. See PATA GENERAL, Table 5 for size of the Flashing Arrow Panel.
7. Shadow vehicle shall be equipped with a Truck Mounted Attenuator (TMA) on Expressways. Use of a TMA is optional on All Other Highways when a shadow vehicle is used.

PUBLICATION 213
LONG-TERM STATIONARY OPERATION - FOUR-LANE, UNDIVIDED HIGHWAY
WORK AREA REQUIRING CLOSURE OF ONE SIDE OF THE ROADWAY

NOTES

1. Remove conflicting pavement markings.
2. When paved shoulders having a width of 8 ft or more are closed, channelizing devices should be used to close the shoulder in advance of the shifting taper (see PATA 7).
3. See PATA GENERAL, Table 5 for size of the Flashing Arrow Panel.
4. The maximum length of temporary one-lane operation, excluding transitions, should not exceed approximately 3 miles. Temporary one-lane operations longer than approximately 3 miles shall only be permitted if justified by an engineering analysis of crossover locations, traffic operations, safety, and other related factors.
5. The alignment of the crossover may be designed as a reverse curve. When the crossover follows a curved alignment, the design criteria contained in Publication 13M (Design Manual Part 2-Highway Design) should be used.
6. For existing concrete pavements, temporary bituminous overlays should be used as shown to cover misleading pavement joints.
7. Signing for this approach shall follow the same configuration as the other direction, using the W20-5L and W4-2L Signs in place of the W20-5R and W4-2R Signs respectively.
8. Where speed or volume is higher, signing such as additional Right Lane Closed XX ft. Sign (W20-5R), Left Lane Closed XX ft. Sign (W20-5L) or Be Prepared To Stop Sign (W3-4) should be used in advance of the W20-1 sign.
9. Where channelizing devices are used instead of pavement markings for edge lines, the spacing shall be $\frac{1}{2}$ D Max.
10. Shadow vehicle shall be equipped with a Truck Mounted Attenuator (TMA) on Expressways. Use of a TMA is optional on All Other Highways when a shadow vehicle is used.

PUBLICATION 213
LONG-TERM STATIONARY OPERATION
DIVIDED OR ONE-WAY HIGHWAY - WORK AREA IN THE LEFT OR RIGHT LANE

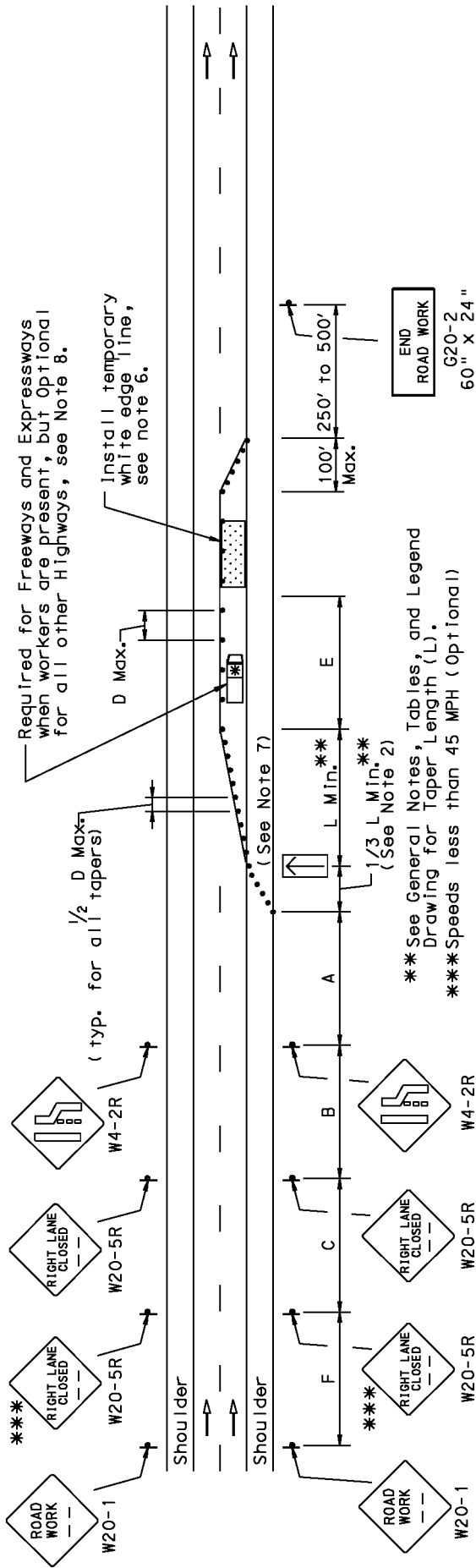

* Distances may be increased for downgrades or other conditions that affect stopping sight distance.

All Highways (except freeways and expressways)	
MPH	E*
25	50
30	60
35	70
40	80
45	90
50	100
55	110
Freeways and Expressways	
50	100
55	110
60	120
65	130

Distance plaques on Advance Warning signs shall be the same series type.

Example: either all XXX ft. or all "AHEAD"

CONDITION 1: All Highways (except Freeways and Expressways):

- A = 500 ft.
- B = 1000 ft., W20-5R sign distance plaque to read 1500 ft.
- C = 1140 ft., W20-5R sign distance plaque to read 1/2 MILE (Distance C and the second W20-5R sign may be eliminated if speeds are less than 45 MPH)
- F = 1/2 MILE, W20-1 sign distance plaque to read 1 MILE or (if second W20-5R is eliminated, F will be 1140 ft., and the W20-1 sign distance plaque to read 1/2 MILE)

CONDITION 2: For Urban Streets

- A, B and F = 200 ft. and sign distance plaque to read "AHEAD"

CONDITION 3: For Freeway and Expressway Highways

- A = 1000 ft.
- B = 1640 ft., W20-5R sign distance plaque to read 1/2 MILE
- C = 2640 ft., W20-5R sign distance plaque to read 1 MILE
- F = 1 MILE, W20-1 sign distance plaque to read 2 MILES

PUBLICATION 213
LONG-TERM STATIONARY OPERATION
DIVIDED OR ONE-WAY HIGHWAY - WORK AREA IN THE LEFT OR RIGHT LANE

NOTES

1. Remove conflicting pavement markings.
2. When paved shoulders having a width of 8 ft or more are closed, channelizing devices should be used to close the shoulder in advance of the merging taper.
3. For left lane closures, the Left Lane Closed Sign (W20-5L) shall be used in place of the W20-5R Sign, and the Pavement Width Transition-Left Lane Ends Sign (W4-2L) shall be used in place of the W4-2R Sign.
4. When a highway-rail grade crossing exists within the work zone, or it is anticipated that queues resulting from the lane closure might extend through a highway-rail grade crossing, provisions shall be made to eliminate conflicts, which may require placing a flagger at the crossing. Coordination with the railroad is essential.
5. Where speed or volume is higher, signing such as additional Right Lane Closed XX ft Sign (W20-5R) or Be Prepared To Stop Sign (W3-4) should be used in advance of the W20-1 sign.
6. Where channelizing devices are used instead of pavement markings for edge lines, the spacing shall be 1/2 D Max.
7. See PATA GENERAL, Table 5 for size of the Flashing Arrow Panel.
8. Shadow vehicle shall be equipped with a Truck Mounted Attenuator (TMA) on Expressways and Freeways. Use of a TMA is Optional on all other Highways when a shadow vehicle is used.

PUBLICATION 213
LONG-TERM STATIONARY OPERATION
THREE LANE, DIVIDED OR ONE-WAY ROADWAY - WORK AREA IN THE CENTER LANE

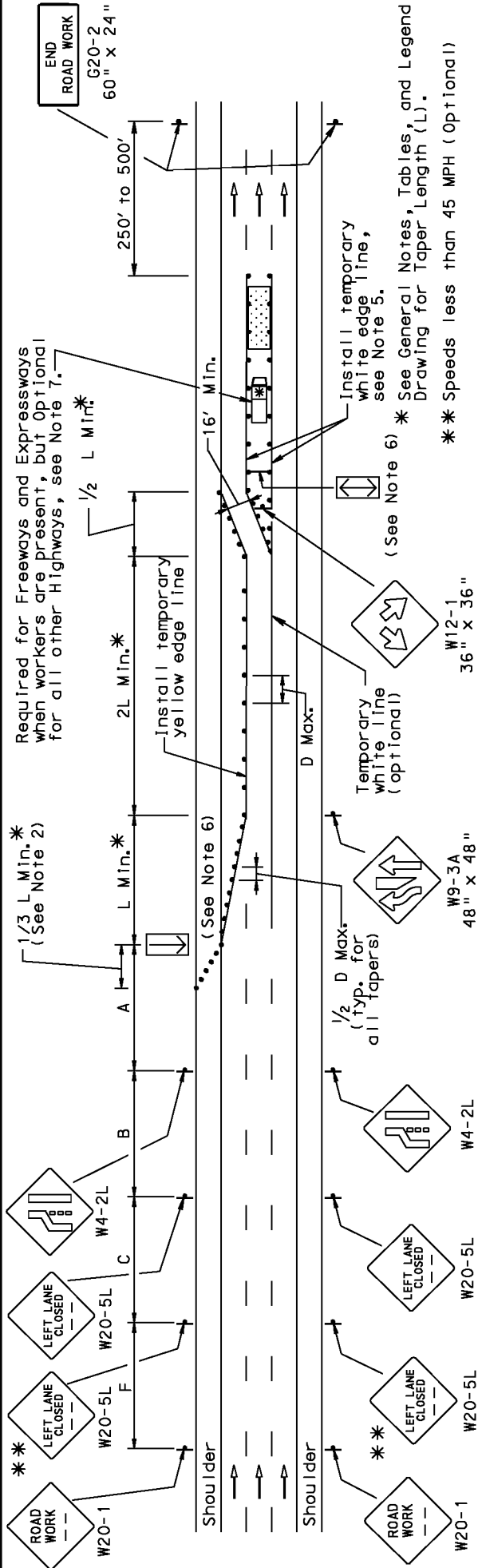

Distance plaques on Advance Warning signs shall be the same series type.
Example: either all XXX ft. or all "AHEAD"

CONDITION 1: All Highways (except Freeways and Expressways)
A = 500 ft.
B = 1000 ft., W20-5L sign distance plaque to read 1500 ft.
C = 1040 ft., W20-1 sign distance plaque to read 1/2 MILE.
(Distance C and the second W20-5AR sign may be eliminated if speeds are less than 45 MPH)
D = 2 times the normal speed limit.
F = 1/2 Mile, W20-1 sign distance plaque to read 1 MILE or (if second W20-5L is eliminated, F will be 1140 ft., and the W20-1 sign distance plaque to read 1/2 MILE)

CONDITION 2: For Urban Streets
A, B and C = 200 ft. and sign distance plaque to read "AHEAD"
D = 2 times the normal speed limit.

CONDITION 3: For Freeway and Expressway Highways
A = 1000 ft.
B = 1640 ft., W20-5L sign distance plaque to read 1/2 MILE
C = 2640 ft., W20-1 sign distance plaque to read 1 MILE.
D = 2 times the normal speed limit.

Notes:
1. Remove conflicting pavement markings.
2. When paved shoulders having a width of 8 ft or more are closed, channelizing devices should be used to close the shoulder in advance of the merging taper.
3. A reversed pattern, beginning with a right lane closure, may also be used.
4. Where speed or volume is higher, signing such as additional Left Lane Closed XX ft Sign (W20-5L) or Be Prepared To Stop Sign (W3-4) should be used in advance of the W20-1 sign.
5. Where channelizing devices are used instead of pavement markings for edge lines, the spacing shall be 1/2 D Max.
6. See PATA GENERAL, Table 5 for size of the Flashing Arrow Panel.
7. Shadow vehicle shall be equipped with a Truck Mounted Attenuator (TMA) on Expressways and Freeways. Use of a TMA is optional on all other Highways when a shadow vehicle is used.

PATA
34

PUBLICATION 213
 LONG-TERM STATIONARY OPERATION
 LANE CLOSURE NEAR A FREEWAY OR EXPRESSWAY ENTRANCE RAMP

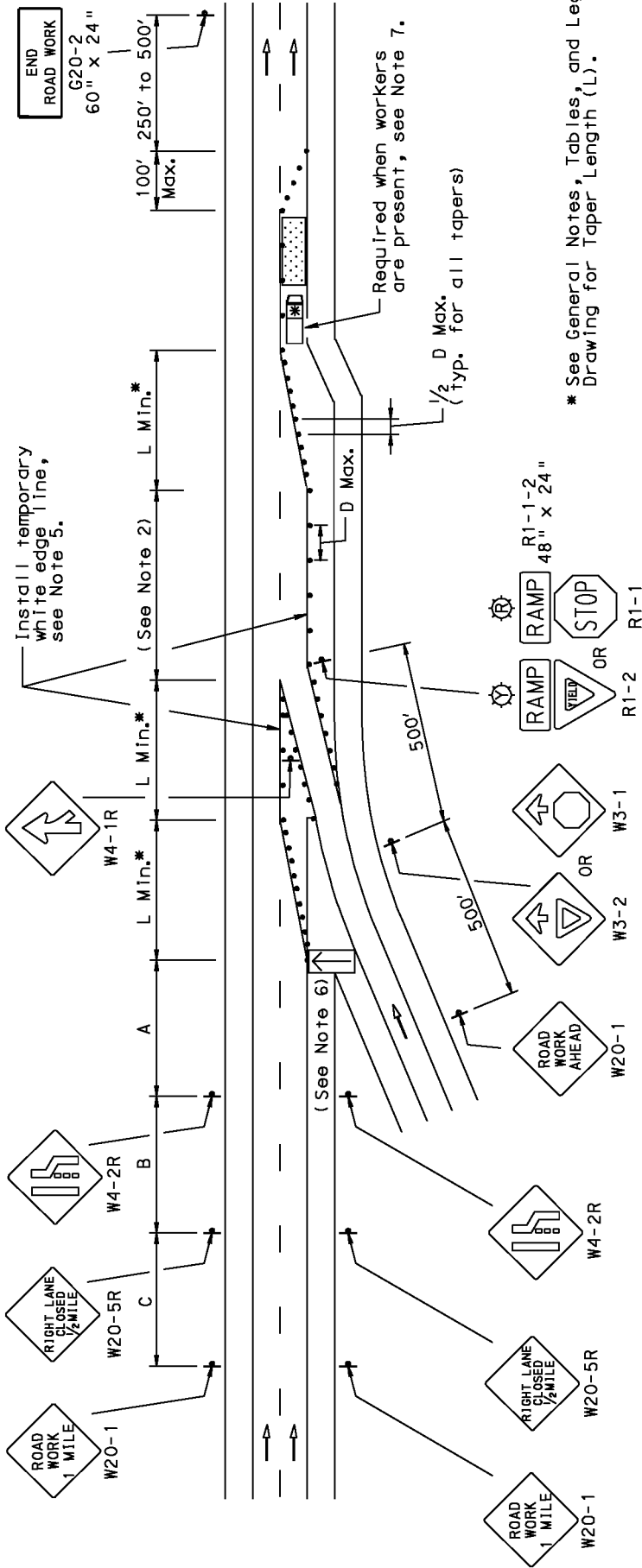

A = 1000 ft.
 B = 1640 ft., W20-5R sign distance plaque to read 1/2 MILE.
 C = 2640 ft., W20-1 sign distance plaque to read 1 MILE.
 D = 2 times the normal speed limit.

NOTES

1. Remove conflicting pavement markings.
2. An acceleration lane of sufficient length should be provided whenever possible.
3. Where inadequate acceleration distance exists for the temporary entrance, the Yield (R1-2) and Yield Ahead (W3-2) Signs shall be replaced with Stop (R1-1) and Stop Ahead (W3-1) Signs.
4. Where speed or volume is higher, signing such as additional Right Lane Closed XX ft Sign (W20-5R) or Be Prepared To Stop Sign (W3-4) should be used in advance of the W20-1 sign.
5. Where channelizing devices are used instead of pavement markings for edge lines, the spacing shall be 1/2 D Max.
6. See PATA GENERAL, Table 5 for size of the Flashing Arrow Panel.
7. Shadow vehicle shall be equipped with a Truck Mounted Attenuator (TMA).

PUBLICATION 213
LONG-TERM STATIONARY OPERATION
TWO-WAY TRAFFIC ON ONE ROADWAY OF A NORMALLY DIVIDED HIGHWAY

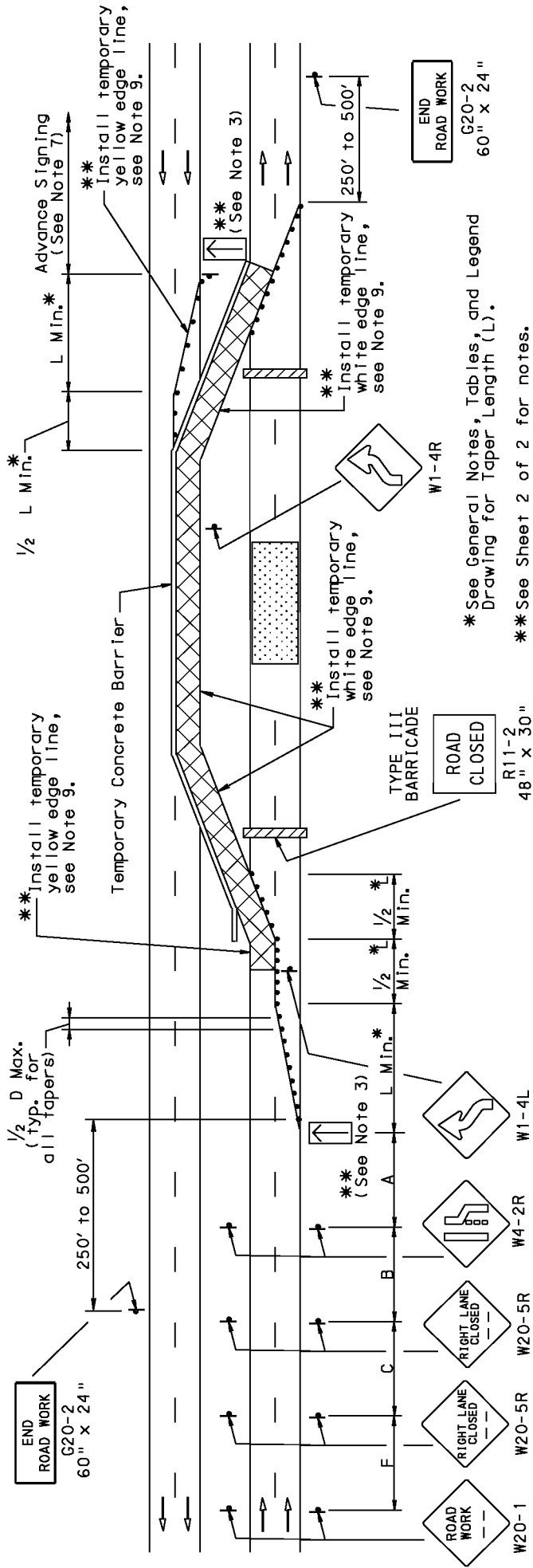

* See General Notes, Tables, and Legend Drawing for Taper Length (L).
** See Sheet 2 of 2 for notes.

Distance plaques on Advance Warning signs shall be the same series type.

Example: either all XXX ft. or all "AHEAD"

- CONDITION 1: All Highways (except Freeways and Expressways)
- A = 500 ft.
 - B = 1000 ft., W20-5R sign distance plaque to read 1500 ft.
 - C = 1640 ft., W20-5R sign distance plaque to read 1/2 MILE
 - D = 2 times the normal speed limit.
 - F = 1/2 Mile, W20-1 sign distance plaque to read 1 MILE

- CONDITION 2: For Urban Streets
- A, B and F = 200 ft. and sign distance plaque to read "AHEAD"
 - D = 2 times the normal speed limit.

- CONDITION 3: For Freeway and Expressway Highways
- A = 1000 ft.
 - B = 1640 ft., W20-5AR sign distance plaque to read 1/2 MILE
 - C = 2640 ft., W20-5AR sign distance plaque to read 1 MILE
 - D = 2 times the normal speed limit.
 - F = 1 Mile, W20-1 sign distance plaque to read 2 MILES

- LEGEND:
- Temporary Pavement
 - Temporary Concrete Barrier

PATA
38

PUBLICATION 213
LONG-TERM STATIONARY OPERATION
TWO-WAY TRAFFIC ON ONE ROADWAY OF A NORMALLY DIVIDED HIGHWAY

NOTES

1. Remove conflicting pavement markings.
2. When paved shoulders having a width of 8 ft or more are closed, channelizing devices should be used to close the shoulder in advance of the merging taper (see PATA 7).
3. See PATA GENERAL, Table 5 for size of the Flashing Arrow Panel.
4. The maximum length of temporary one-lane operation, excluding transitions, should not exceed approximately 3 miles. Temporary one-lane operations longer than approximately 3 miles shall only be permitted if justified by an engineering analysis of crossover locations, traffic operations, safety, and other related factors.
5. The alignment of the crossover may be designed as a reverse curve. When the crossover follows a curved alignment, the design criteria contained in Publication 13M (Design Manual Part 2-Highway Design) should be used.
6. For existing concrete pavements, temporary bituminous overlays should be used as shown to cover misleading pavement joints.
7. Signing for this approach shall follow the same configuration as the other direction, using the W20-5L and W4-2L Signs in place of the W20-5R and W4-2R Signs respectively.
8. Where speed or volume is higher, signing such as additional Right Lane Closed XX ft Sign (W20-5R) or Be Prepared To Stop Sign (W3-4) should be used in advance of the W20-1 sign.
9. Where channelizing devices are used instead of pavement markings for edge lines, the spacing shall be $\frac{1}{2}$ D Max.

PUBLICATION 213
 LONG-TERM STATIONARY OPERATION
 ANY HIGHWAY - DETOUR OF A NUMBERED TRAFFIC ROUTE

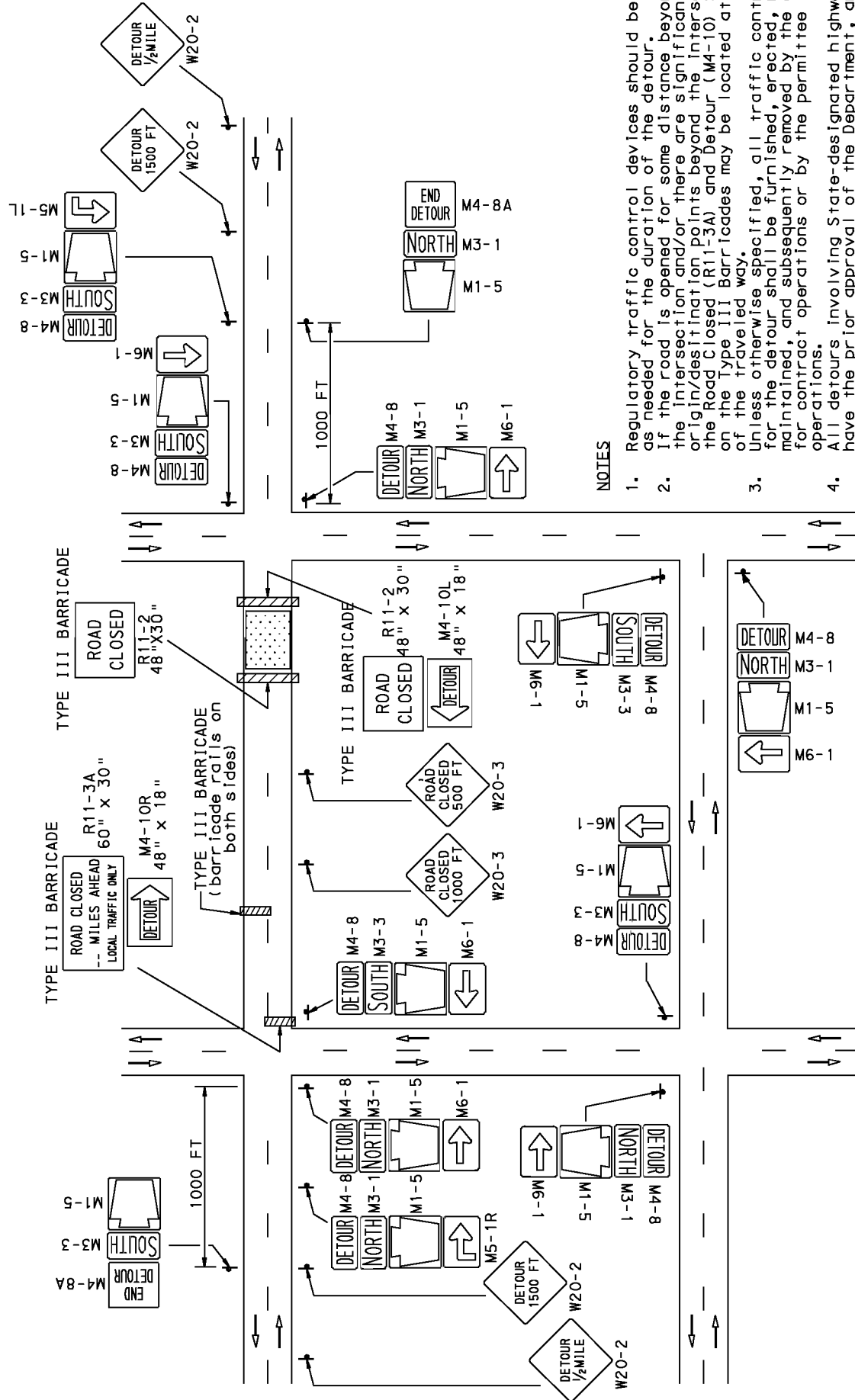

NOTES

1. Regulatory traffic control devices should be modified as needed for the duration of the detour.
2. If the road is opened for some distance beyond the intersection and/or there are significant origin/destination points beyond the intersection, the Road Closed (R11-3A) and Detour (M4-10) Signs on the Type III Barricades may be located at the edge of the traveled way.
3. Unless otherwise specified, all traffic control devices for the detour shall be furnished, erected, modified, maintained, and subsequently removed by the contractor for contract operations or by the permittee for permit operations.
4. All detours involving State-designated highways shall have the prior approval of the Department, and all detours involving local highways shall have the prior approval of the appropriate local authorities.
5. The size of the Route Marker Assemblies shall comply with Publication 236M.
6. Where speed or volume is higher, additional signing should be used.
7. For scheduled or emergency closures of 7 consecutive days or less, PATA 39B may be used.

PATA
 39d

PUBLICATION 213
 LONG-TERM STATIONARY OPERATION
 ANY HIGHWAY - DETOUR OF AN UNNUMBERED TRAFFIC ROUTE

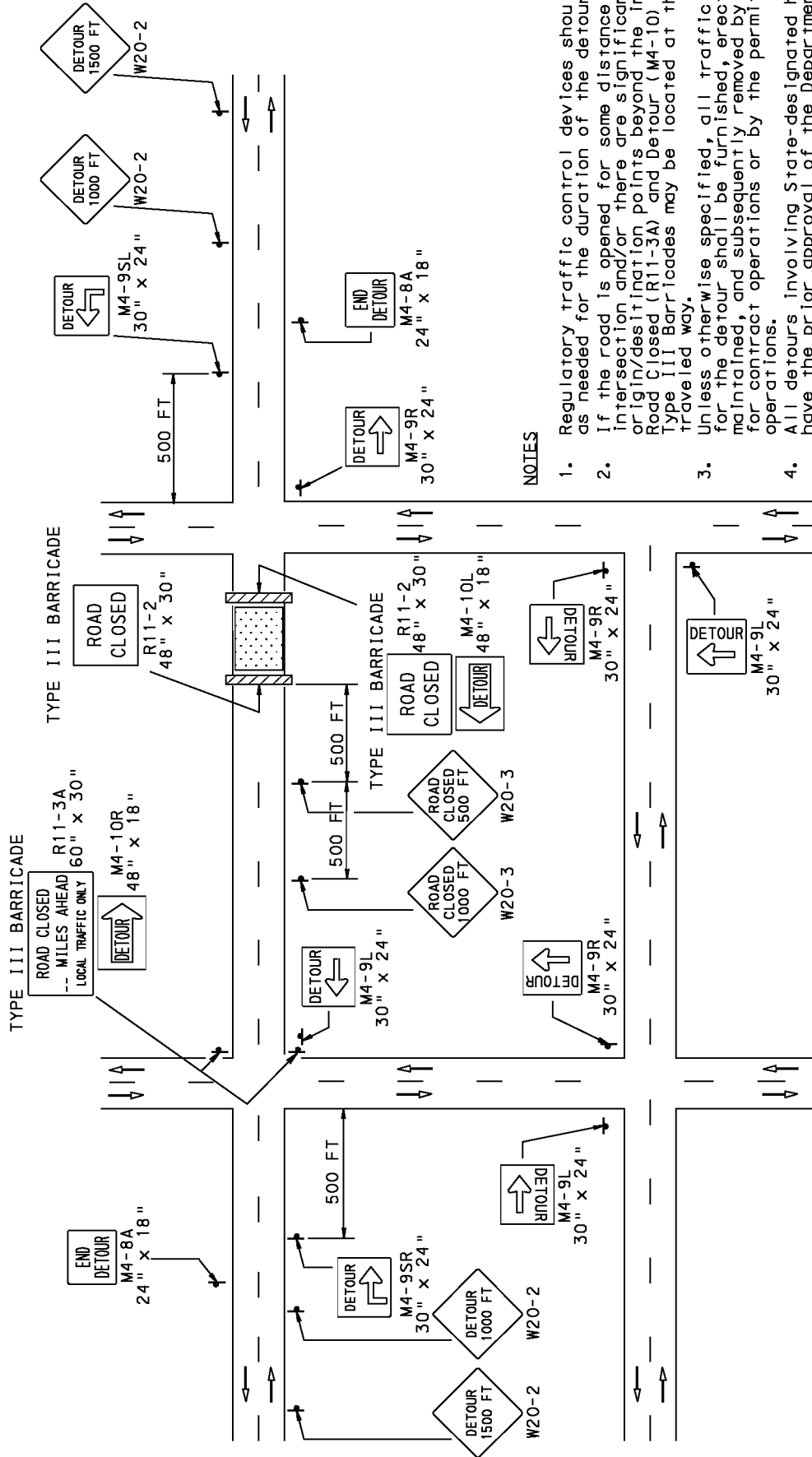

NOTES

1. Regulatory traffic control devices should be modified as needed for the duration of the detour.
2. If the road is opened for some distance beyond the intersection and/or there are significant origin/destination points beyond the intersection, the Road Closed (R11-3A) and Detour (M4-10) Signs on the Type III Barricades may be located at the edge of the traveled way.
3. Unless otherwise specified, all traffic control devices for the detour shall be furnished, erected, modified, maintained, and subsequently removed by the contractor for contract operations or by the permittee for permit operations.
4. All detours involving State-designated highways shall have the prior approval of the Department, and all detours involving local highways shall have the prior approval of the appropriate local authorities.
5. At locations where there are overlapping detours or several detours within the same area, street names may be added above the M4-9L and M4-9R Signs, or signs with different colored arrows may be used to designate the different detour routes. The design and application of signs displaying colored arrows shall comply with Publication 236M.
6. Turn Arrow should be used in advance of a turn.
7. Where speed or volume is higher, additional signing should be used.

PUBLICATION 213
 SHORT-TERM AND LONG-TERM STATIONARY OPERATION
 SIDEWALK DETOUR OR DIVERSION

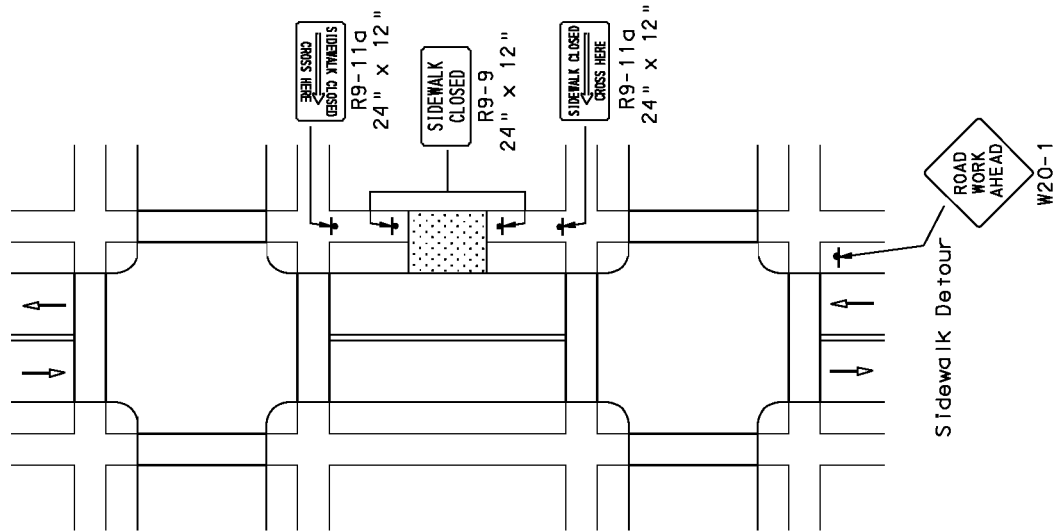

Sidewalk Detour

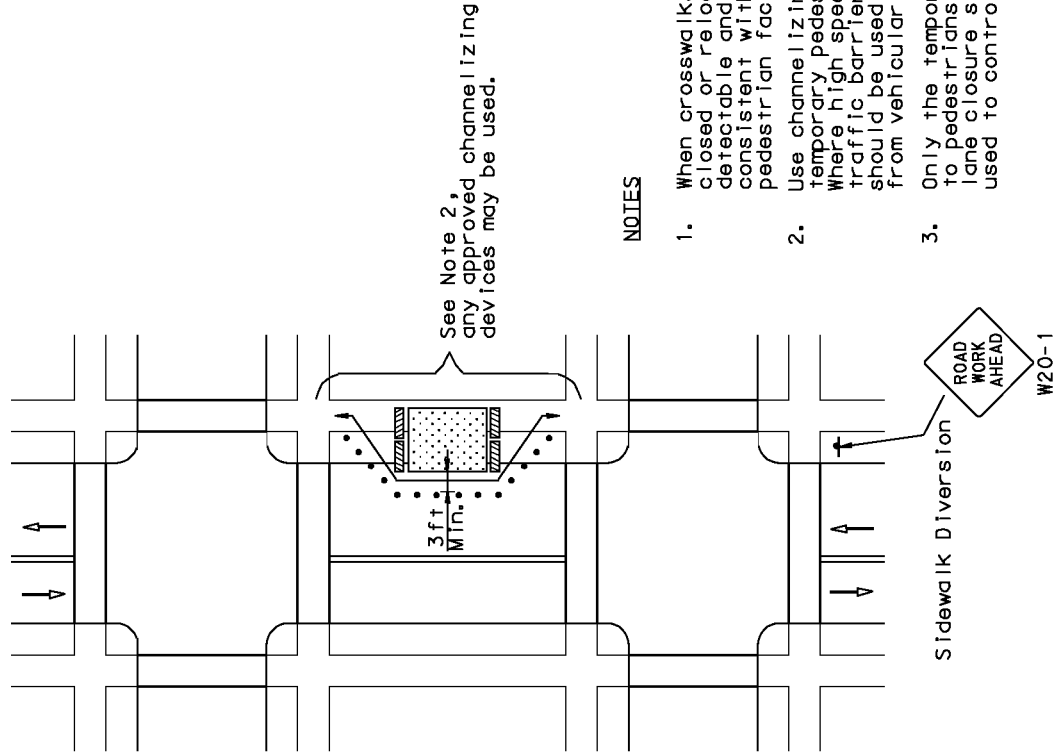

Sidewalk Diversion

See Note 2, any approved channelizing devices may be used.

NOTES

1. When crosswalks or other pedestrian facilities are closed or relocated, temporary facilities shall be detectable and shall include accessibility features consistent with the features present in the existing pedestrian facility.
2. Use channelizing devices to separate and maintain temporary pedestrian walkway while sidewalk is closed. Where high speeds are anticipated, a temporary traffic barrier and, if necessary, a crash cushion should be used to separate the temporary walkways from vehicular traffic.
3. Only the temporary traffic control devices related to pedestrians are shown. Other devices, such as lane closure signing or Road Narrows signs, may be used to control vehicular traffic.

PUBLICATION 213
 SHORT-TERM AND LONG-TERM STATIONARY OPERATION
 CROSSWALK CLOSURES AND PEDESTRIAN DETOURS

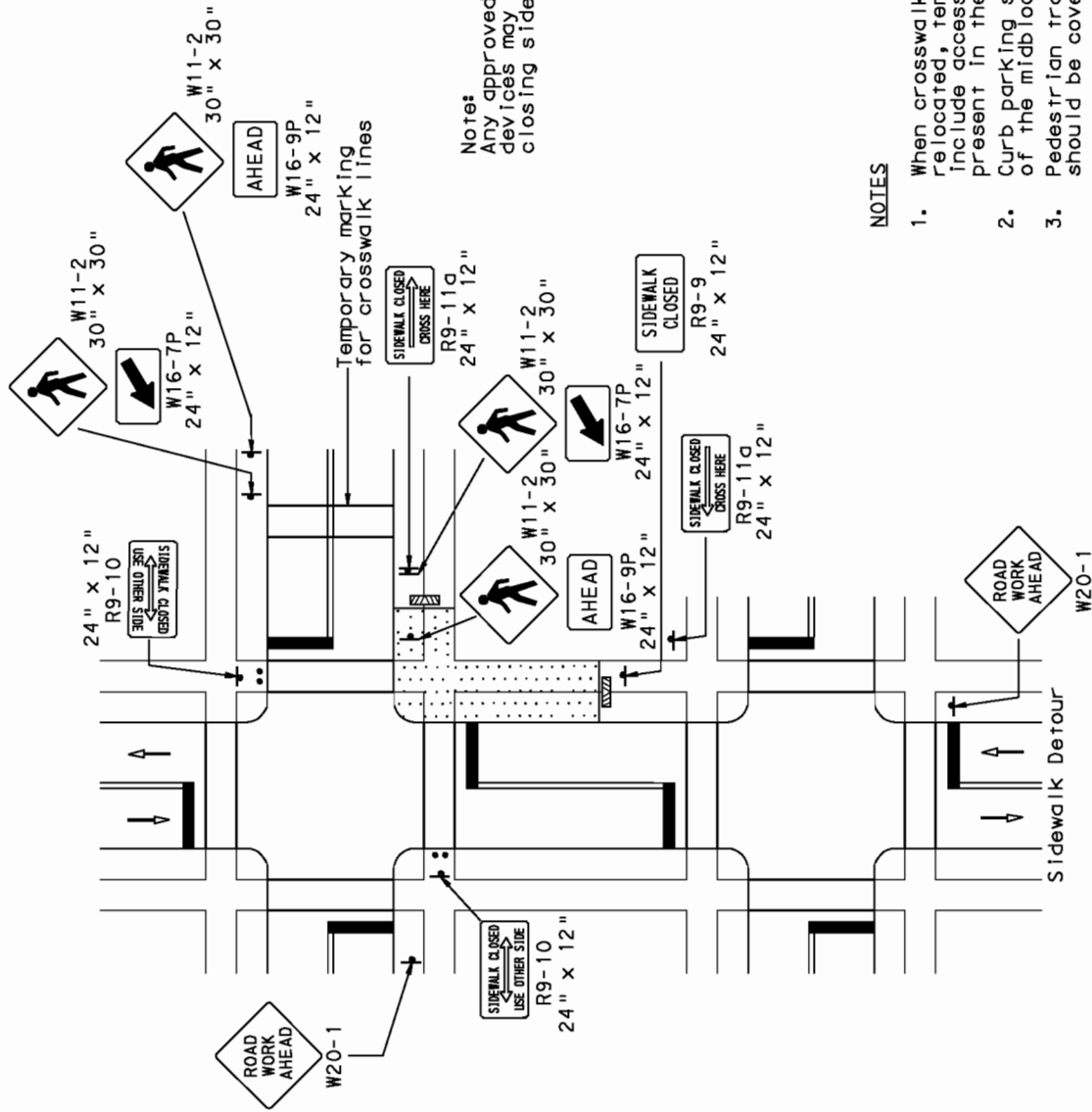

Note:
 Any approved channelizing devices may be used for closing sidewalk.

NOTES

1. When crosswalks or other pedestrian facilities are closed or relocated, temporary facilities shall be detectable and shall include accessibility features consistent with the features present in the existing pedestrian facility.
2. Curb parking shall be prohibited for at least 50 ft in advance of the midblock crosswalk.
3. Pedestrian traffic signal displays controlling closed crosswalks should be covered or deactivated.
4. Only the temporary traffic control devices related to pedestrians are shown. Other devices, such as lane closure signing or Road Narrows signs, may be used to control vehicular traffic.

PUBLICATION 213
 TEMPORARY BITUMINOUS RUMBLE STRIP PATTERNS

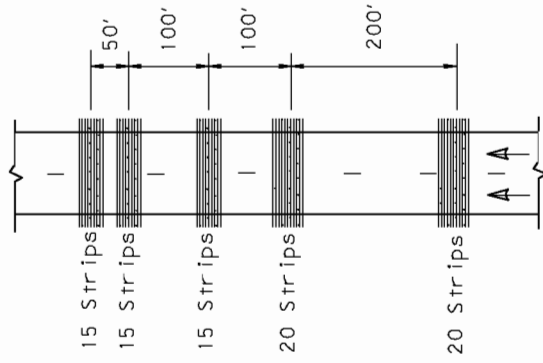

RUMBLE STRIP PATTERN A

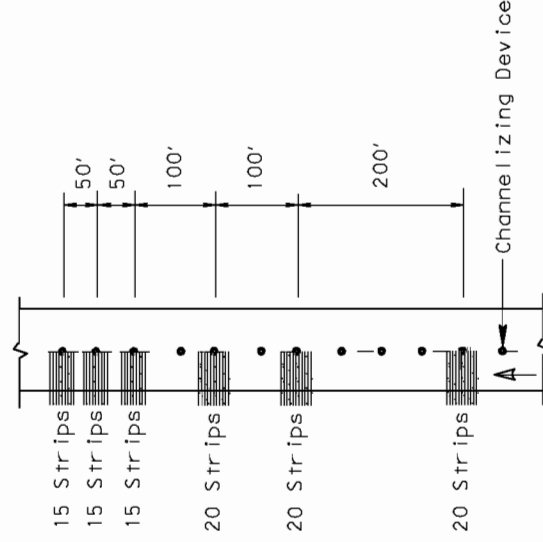
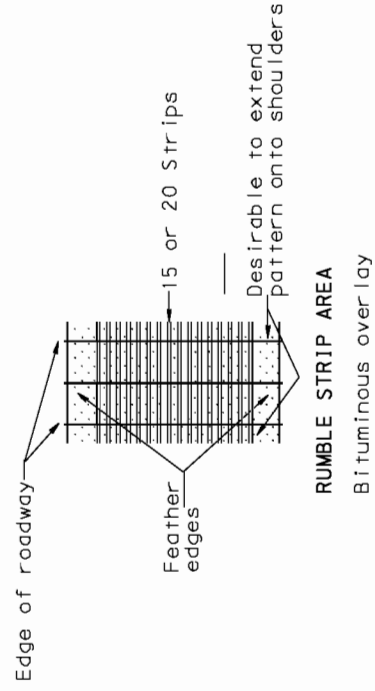

RUMBLE STRIP PATTERN B

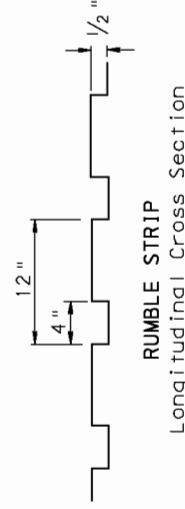

Appendix

Appendix A - Temporary/Portable Traffic Signals general notes and applications
Appendix B – Temporary Barrier Deflection Distances

Appendix A

Temporary Traffic Control Signal Documentation

Document Type Index
Temporary Traffic Control Signal Requirements and Timeframes
Process for Obtaining PennDOT Approval to Use Temporary Traffic Control Signals
Blanket Permits
Application for Permit to Operate Temporary Traffic Control Signals
Temporary Traffic Control Signal Permit
Application Instructions for Permit to Operate Temporary Traffic Control Signals
Example Problem: Application for Permit to Operate Temporary Traffic Control Signals
Guidelines for the Selection of Temporary Traffic Control Signals in Work Zones
Temporary Traffic Control Signals Non-Compliance Documentation Form
Temporary Traffic Control Signals User Comment Form

Temporary Traffic Control Signal Requirements and Timeframes

Type of Application	Publication 213 Figure	PennDOT Approval Required Prior to Use	Advance Site Visit Required by User	Application Required	Site-Specific Drawing Required	Deadline for District Receipt of All Required Materials
Long-Term Stationary Operation Fixed Supports	PATA 26e L	X	X	X	X	At least 15 working days prior to desired usage
Long-Term Stationary Operation Trailer-Mounted Portable Traffic Control Signals	PATA 26e PL	X	X	X	X	At least 15 working days prior to desired usage
Short-Term Stationary Operation Pedestal-Mounted Portable Traffic Control Signals Manually-Controlled	PATA 26e M-1	X	X	X		At least 3 full working days prior to desired usage
Short-Term Stationary Operation Trailer-Mounted Portable Traffic Control Signals Manually-Controlled	PATA 26e M-2	X	X	X		At least 3 full working days prior to desired usage
Short-Term Stationary Operation Pedestal-Mounted Portable Traffic Control Signals Non-Complex Conditions	PATA 26e NC-1	X	X	X		At least 3 full working days prior to desired usage
Short-Term Stationary Operation Trailer-Mounted Portable Traffic Control Signals Non-Complex Conditions	PATA 26e NC-2	X	X	X		At least 3 full working days prior to desired usage
Short-Term Stationary Operation Pedestal-Mounted Portable Traffic Control Signals Complex Conditions	PATA 26e C-1	X	X	X	X	At least 15 working days prior to desired usage
Short-Term Stationary Operation Trailer-Mounted Portable Traffic Control Signals Complex Conditions	PATA 26e C-2	X	X	X	X	At least 15 working days prior to desired usage
Short-Term Stationary Operation Pedestal-Mounted Portable Traffic Control Signals Blanket Permit		X	X	X		At least 15 working days for initial blanket permit request; at least 3 full working days prior to each usage under the blanket permit
Short-Term Stationary Operation Trailer-Mounted Portable Traffic Control Signals Blanket Permit		X	X	X		At least 15 working days for initial blanket permit request; at least 3 full working days prior to each usage under the blanket permit

Process for Obtaining PennDOT Approval to Use Temporary Traffic Control Signals

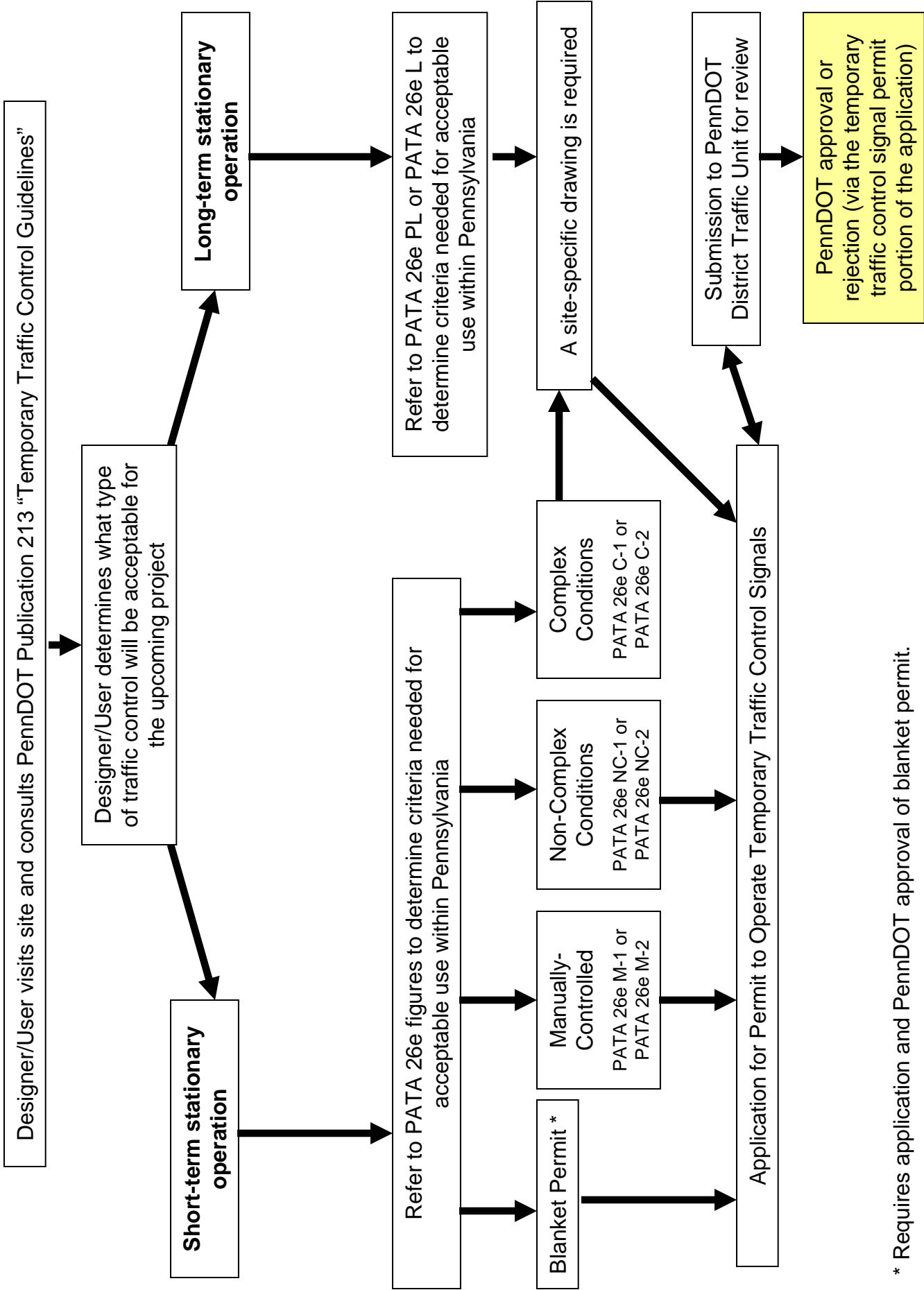

* Requires application and PennDOT approval of blanket permit.

Blanket Permits

The following information below will provide you with the requirements when considering a blanket permit for temporary traffic control signals.

What is a blanket permit?

- For repeat users of portable traffic control signals, PennDOT's appropriate Engineering District Office may issue a blanket temporary traffic control signal permit covering multiple locations and dates of operation for up to a one-year period. This action will only be considered by PennDOT if that user has properly used portable traffic control signals in a safe and efficient manner on three or more past deployments without problems and in compliance with PennDOT requirements.
- PennDOT's Bureau of Highway Safety and Traffic Engineering (BHSTE) will be involved in the blanket permit process. Although permits are issued by the appropriate Engineering District Office, BHSTE will participate in the evaluation process to determine whether a particular portable traffic control signal user can be issued their initial blanket permit in each Engineering District. BHSTE will provide the overall blanket permit approval number, participate in any blanket permit revocation proceedings, and will keep track of users who have been issued blanket permits statewide.

What types of operations can be covered by a blanket permit?

- Blanket permits can only be issued for short-term stationary operations (manual control or non-complex conditions) that satisfy the criteria and provisions of PATA 26e M-1, PATA 26e M-2, PATA 26e NC-1, or PATA 26e NC-2, except for emergency work as defined in PennDOT Publication 212. See Note 2 of each figure.
- Blanket permits **cannot** be used for portable traffic control signal usage involving either long-term operations or short-term operations with complex conditions that are governed by PATA 26e PL, PATA 26e C-1, or PATA 26e C-2.

Who can apply for a blanket permit?

- Any repeat user of portable traffic control signals who agrees to the responsibilities, terms, and conditions as outlined herein.
- The blanket permit will be issued to up to two specific individuals (representing a company), and not to companies in general.

What are the roles and responsibilities of the blanket permittee?

- Responsible for the proper installation, maintenance, and operation of the portable traffic control signal system as specified in PennDOT Publication 213 and the temporary traffic control signal permit.
- Work closely with the work crew to provide safe and proper operations as specified in PennDOT Publication 213 and the temporary traffic control signal permit. Safety will be strictly enforced, and will not be compromised when using the devices.
- Assist the work crew with PennDOT Publication 213 and temporary traffic control signal permit requirements for portable traffic control signal usage.
- Provide technical and expert assistance on the use of the devices before, during, and after deployments to the contractors' personnel.

- Take responsibility to ensure that the devices are working properly.
- Approved products as specified in PennDOT Publication 35 (Bulletin 15) must be used.
- Ensure the upkeep of the devices to PennDOT specifications and requirements maintained by the Bureau of Highway Safety and Traffic Engineering (BHSTE).
- Provide documentation, satisfactory to PennDOT, showing that the individual successfully completed a training course given by the manufacturer on the operation of the portable traffic control signal system that is being deployed under the blanket permit.
- Ensure proper all-red clearance intervals and yellow change intervals are used as specified in PennDOT Publication 213 and the temporary traffic control signal permit.
- Ensure appropriate green intervals are used based on traffic conditions. Ensure this is evaluated several times a day, and all changes should be documented.
- Ensure that good records are kept of any changes during the operation of the devices.
- Ensure that proper documentation is maintained on-site (including the temporary traffic control signal permit, PennDOT Publication 213, etc.).
- Develop and document a contingency plan by the permittee prior to the deployment of the devices to establish procedures in the event of device failure or malfunction, or in the event of changing conditions or unforeseen circumstances.
- Establish a designated on-site liaison from work crew. Topics to be covered with the on-site liaison include a contingency plan, basic programming and operation, take-down procedures, traffic monitoring responsibilities, driveway control, etc.
- Provide the initial programming and the initial monitoring of the portable traffic control signals each day. All changes during the day should be made under the direction of the permittee and documented.
- Be on-site at the start of signal usage each day. Provide emergency protocols and a contingency plan to address situations involving device malfunctions or changing conditions. Also, provide a direct number whereby the blanket permittee can be contacted at all times during signal usage.
- Provide instructions to the work crew about proper removal procedures and how to place devices into a flash mode before going dark.
- Visit the site in advance to ensure that proper usage can be achieved at the location of the upcoming deployment.
- Continue to follow the appropriate processes outlined in PennDOT Publication 213 for obtaining PennDOT approval to use portable traffic control signals. The deadline for PennDOT District Office receipt of all required materials for the blanket permit request is at least 15 working days prior to the first desired usage date. Thereafter, required materials must be received by the appropriate District Office at least 3 full working days prior to each usage under an established blanket permit.
- Coordinate yearly with PennDOT's Central Office and District Offices to ensure proper installations are occurring. Also, this will allow for a working relationship where the blanket permittee will be up-to-date with respect to the latest requirements and guidance documents.

What is the process/procedure to follow if an individual wants to be considered as a future blanket permittee?

- Submit a written request to BHSTE and the appropriate Engineering District(s) identifying the individuals seeking to be evaluated for future blanket permit consideration. Indicate the Engineering Districts where blanket permit consideration is being sought. Clearly indicate acceptance of the blanket permittee roles and responsibilities as outlined herein. Provide written documentation from the manufacturer of each portable traffic control signal system that will be deployed indicating that each individual seeking a blanket permit has successfully completed a training course given by the manufacturer on the operation of that signal system.
- After receipt of the written request, PennDOT will contact the applicant to discuss the evaluation process and associated expectations. A series of successful trial deployments will need to be completed.
- The appropriate processes outlined in PennDOT Publication 213 for obtaining PennDOT approval to use portable traffic control signals must be followed for the trial deployments. Failure to do so may result in rejection of the trial deployment.

How many successful trial deployments must be completed before obtaining a blanket permit?

- The initial application will begin the evaluation of the trial deployments. Previous deployments will not be considered during the blanket permit evaluation.
- A minimum of three proper deployments by the individual desiring to be a future blanket permittee, with at least one proper deployment in each Engineering District where a blanket permit is desired.
- PennDOT will allow a maximum of two individuals from the same company to be evaluated on each trial deployment for the purposes of being considered as a future blanket permittee.
- BHSTE will be actively involved in monitoring the trial deployments, and feedback received from District Office personnel, the work crew, the supplier/manufacturer, and others will be considered.

Upon successful completion of the trial deployments, what are the next steps?

- PennDOT will document all comments and advise the applicant of successful completion of the trial deployments.
- BHSTE will work with District Office personnel to ensure that a blanket permit is issued to applicants that fulfill requirements.

What about blanket permit revocation?

- A blanket permit must be renewed each year.
- A blanket permit can be revoked at any time for poor performance by the Engineering District. BHSTE will be involved in any revocation proceedings.
- If a blanket permit is revoked, that individual will not be allowed to submit for a blanket permit application for at least one year. Future submissions should follow the same procedures as a first-time applicant.



**APPLICATION FOR PERMIT TO OPERATE
TEMPORARY TRAFFIC CONTROL SIGNALS**

Applicant's Contact Information

Applicant's Name: _____

Applicant's Company: _____

Company Address: _____

Company Phone No.: _____ Company Fax No.: _____

Cellular Phone No.: _____ E-mail Address: _____

Name of Emergency Contact Person: _____ Cellular Phone No.: _____
(Must be available 24 hrs./day, 7 days/week during period of usage.)

Description of Traffic Control Device

Type of Device (check one)	Mounted on Fixed Supports	Trailer-Mounted	Pedestal-Mounted	Automated Flagger Assistance Device (AFAD)	Other (explain)

Traffic Control Device Manufacturer: _____ Manufacturer's Model No.: _____

PennDOT Approval No.: _____

Work Zone Information

Was a site visit performed prior to submitting this application? Yes ___ No ___

Date of Traffic Control Device Usage: Begin _____ End _____

Engineering District: _____ County: _____ Municipality: _____

On State Route (SR): _____ Direction: _____

From: Segment: _____ Offset: _____

To: Segment: _____ Offset: _____

Traffic Control Device Operational Information

Mode of Operation	Manually-Controlled	Pre-Timed	Actuated	Other (explain)
(please check one)				

PennDOT Publication Figure: PATA _____ will be followed.

All-red clearance time is _____ seconds based on assumed traffic speed of _____ mph within one-lane, two-way section.

The proposed minimum green time shall be at least 10 seconds.

The proposed maximum green time shall be determined based on field conditions.

The proposed yellow change interval shall be five (5) seconds unless otherwise indicated by PennDOT.

Applicant Certification

The applicant certifies that the information provided on this application and accompanying documents is true and correct.

The applicant certifies that, if approved, the traffic control devices will be operated and maintained in compliance with PennDOT Publications 212 and 213, and the provisions of the temporary traffic control signal permit as issued by PennDOT.

The applicant agrees that it will indemnify, save harmless and defend (if requested) the Commonwealth of Pennsylvania, its agents, representatives and employees, from all suits, actions or claims of any character, name or description, damages, judgments, expenses, attorneys' fees and compensation arising out of personal injury, death or property damage, sustained or alleged to have been sustained in whole or in part by any and all persons whatsoever as a result of or arising out of any act, omission, neglect or misconduct of the applicant, its officers, agents, contractors or employees, during the period of temporary traffic control signal usage.

BY: _____
Signature of Applicant
Date

Sworn before me this _____ day of _____, 20_____

Notary: _____



TEMPORARY TRAFFIC CONTROL SIGNAL PERMIT

In accordance with the Vehicle Code, the Pennsylvania Department of Transportation (PennDOT) hereby approves the operation of a temporary traffic control signal as follows:

Location: _____

Date(s) of Operation: _____

This permit is issued to, and accepted by, _____, hereinafter known as the Permittee, as follows:

The operation and maintenance of this temporary traffic control signal by the Permittee shall be in accordance with requirements contained on the attached sheets and application, PennDOT's figures governing the use of temporary traffic control signals as contained in PennDOT Publication 213, and the following special requirements:

All work performed by the Permittee with respect to the operation and maintenance of this temporary traffic control signal shall be under and subject to the direction of PennDOT. The said Permittee shall use due diligence in the execution of the work authorized under this permit and shall not obstruct or endanger travel along the said road. All operations must be conducted so as to permit safe and reasonable free travel at all times over the road within the limits of the work herein permitted.

The Permittee agrees to indemnify, save harmless and defend (if requested) the Commonwealth of Pennsylvania, its agents, representatives and employees, from all suits, actions or claims of any character, name or description, damages, judgments, expenses, attorneys' fees and compensation arising out of personal injury, death or property damage, sustained or alleged to have been sustained in whole or in part by any and all persons whatsoever as a result of or arising out of any act, omission, neglect or misconduct of the Permittee, its officers, agents, contractors or employees, during the period of temporary traffic control signal usage.

PennDOT reserves the right to revoke this permit or to suspend the operation of the temporary traffic control signal if the Permittee shall at any time willfully or negligently fail to comply with the conditions contained in this permit or PennDOT Publication 213, or fail to make any changes in the operation of this signal, or to remove it, when so ordered by PennDOT. The Permittee shall maintain the signal in a safe condition at all times. The Permittee shall not make any change in the operation of the temporary traffic control signal as defined in the permit drawings without prior written approval of PennDOT. PennDOT reserves the right to inspect this temporary traffic control signal usage at any time.

Date: _____

Approved: _____
Secretary of Transportation
Commonwealth of Pennsylvania

By: _____
District Executive
Pennsylvania Department of Transportation



APPLICATION INSTRUCTIONS FOR PERMIT TO OPERATE TEMPORARY TRAFFIC CONTROL SIGNALS

Applicant's Contact Information

- **Applicant's Name:** is the individual who will be responsible for the proper placement of the work zone traffic control devices.
- **Applicant's Company:** the Company the Applicant represents.
- **Company Address:** the official mailing address of the Applicant's company.
- **Company Phone No.:** the phone number of the Applicant's company.
- **Company Fax No.:** the fax number of the Applicant's company.
- **Cellular Phone No.:** the Applicant's cellular phone number.
- **Email Address:** the Applicant's e-mail address.
- **Name of Emergency Contact Person:** the person that will be available 24 hrs./day, 7 days/week during the period of usage and who will be responsible for the continued proper usage of the device.
- **Cellular Phone No.:** the emergency contact person's cellular phone number.

Description of Traffic Control Device

Type of Device	Mounted on Fixed Supports	Trailer-Mounted	Pedestal-Mounted	Automated Flagger Assistance Device (AFAD)	Other (explain)
(check one)					

Descriptions of the devices are as follow:

- **Mounted on Fixed Supports:** As defined in the Manual on Uniform Traffic Control Devices (MUTCD), it is a temporary traffic control signal that is temporarily mounted on fixed supports. The fixed supports are typically span wires mounted on temporarily-installed poles. These devices are normally used for long-term stationary applications where appropriate field conditions exist.
- **Trailer-Mounted:** Trailer-mounted portable traffic control signal systems consist of two trailers, with each trailer having a vertical upright and a horizontal arm to accommodate the mounting of at least two signal heads. These devices may be used for short-term stationary and long-term stationary applications where the appropriate conditions exist.
- **Pedestal-Mounted:** Pedestal-mounted portable traffic control signal systems consist of four units, with a pedestal-mounted signal head on each unit. These devices may be used for short-term stationary applications where appropriate field conditions exist.
- **Automated Flagger Assistance Device (AFAD):** A manually-controlled device operated by one or more individuals to safely stop and control traffic through a

work zone. These devices may be used for short-term stationary applications where appropriate field conditions exist.

- **Other (explain):** Other applications which do not fall into the criteria listed above. Please give a detailed description so that proper evaluation may be made.
- **Traffic Control Device Manufacturer:** the manufacturer of the device that will be used for work zone traffic control.
- **PennDOT Approval No.:** the PennDOT device approval number as indicated in PennDOT Publication 35 “Approved Construction Materials (Bulletin 15)”. This number can be accessed through the internet at the listing below:

ftp://ftp.dot.state.pa.us/public/pdf/BOCM_MTD_LAB/PUBLICATIONS/PUB_35/BULLETIN_15.pdf

If problems exist with finding an approval number, please contact either the appropriate PennDOT Engineering District Office or PennDOT Central Office at (717) 783-0333.

Work Zone Location Information

- **Was a site visit performed prior to this application request?:**
 - **Yes:** A proper field visit was made prior to the submission of this application to determine if the device was acceptable and met all of the criteria specified in Publication 213 to safely and efficiently operate the device.
 - **No:** A proper field visit was not made prior to the submission of this application.
- **Date (s) of Traffic Control Device Usage:** Please specify the approximate date and/or dates and times that you would like to use this device. Upon approval of this application, if dates are modified, please contact the appropriate Engineering District representative.
- **Engineering District:** The Engineering District that will be reviewing the completed application.

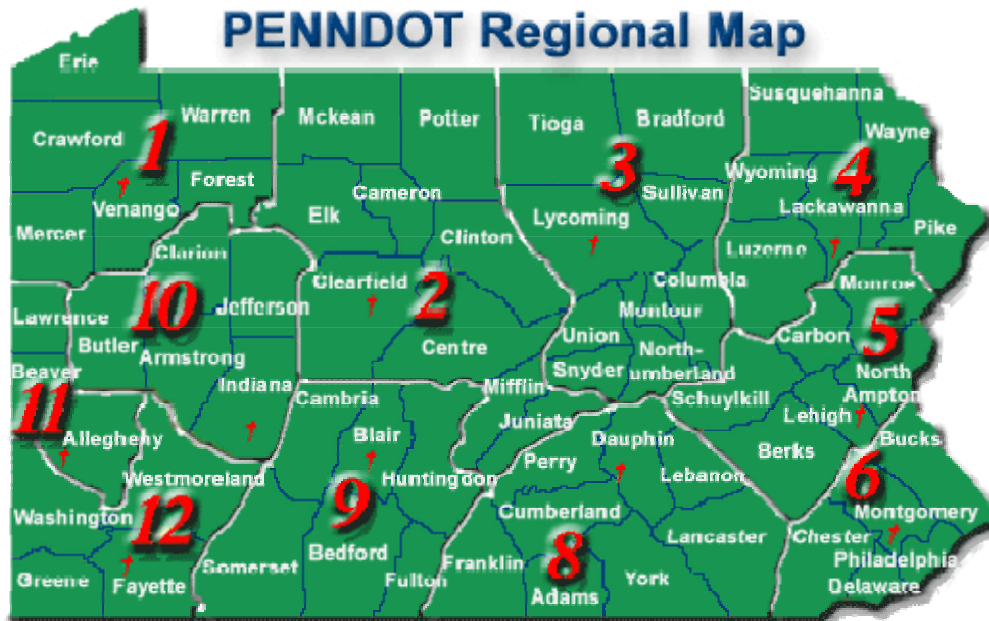

- **County:** the county where the traffic control device would be used.
- **Municipality:** the municipality where the traffic control device would be used.
- **On State Route (SR):** the state highway where the traffic control device would be deployed. For further guidance, please refer to the following link and select the appropriate county map:

<http://www.dot.state.pa.us/Internet/Bureaus/pdPlanRes.nsf/infoBPRCartoCountyType3>

- **Direction:** the direction of travel which may be either North/Southbound or East/Westbound. The link above may help you with the determination of the travel direction.
- **From Segment:** the roadway segment on the State Route the device will be deployed. These segment numbers may be found either on small markers posted along the roadway or from straight-line diagrams.
- **Offset:** the roadway location from the beginning of the segment to the approximate location of the device in feet.
- **From Segment:** the roadway segment on the State Route the device will be deployed. These segment numbers may be found either on small markers posted along the roadway or from straight-line diagrams.
- **Offset:** the roadway location from the beginning of the segment to the approximate location of the device in feet.
- **On Local Road:** Use the local road name. Identify the nearest intersecting roadways when determining the local roadway location.
- **Normal Speed Limit:** this is the legal speed limit on the roadway prior to the beginning of the work. If no speed limit is posted on the roadway, please mark unposted.
- **ADT:** This is also known as Average Daily Traffic. This number can be found by accessing the following link below and selecting the appropriate county map:

<http://www.dot.state.pa.us/Internet/Bureaus/pdPlanRes.nsf/infoBPRTrafficInfoTrafficVolumeMap>

If problems exist with finding an ADT number, please contact either the appropriate PennDOT Engineering District Office or PennDOT Central Office at (717) 783-0333.

- **Maximum Length of One-Lane, Two-Way Traffic Section:** this is the approximate distance between “STOP HERE ON RED” signs in feet. This is very important for determining the proper all-red clearance interval needed to safely and efficiently move traffic through the work zone.
 - **Does the sight distance requirement exceed the thresholds specified in the drawing?:**
 - **Yes:** The sight distance requirements have been met as indicated on the correct Publication 213 drawing.
 - **No:** The sight distance requirements could not be met as indicated on the correct Publication 213 drawing.
 - **Does the site contain intersections within the work zone?:**
 - **Yes:** The site contains an intersection within the work zone.
 - **No:** The site does not contain an intersection within the work zone.
 - **Does the site contain uncontrolled commercial driveways within the work zone?:**
 - **Yes:** The site contains uncontrolled commercial driveways within the work zone.
 - **No:** The site does not contain uncontrolled commercial driveways within the work zone.
 - **Is any roadway approach to the traffic control device on a steep downgrade (5% or more)?**
 - **Yes:** the site contains a steep downgrade of 5% or more.
 - **No:** the site does not contain a steep downgrade of 5% or more.
 - **Does the site contain at-grade railroad crossings within 300 feet of the work zone?**
 - **Yes:** the site contains an at-grade railroad crossing within 300 feet of the work zone.
 - **No:** the site does not contain an at-grade railroad crossing within 300 feet of the work zone.
 - **Provide a Brief Description of the Construction Operation:** Please provide a description of the work being performed in the work zone.
-

Traffic Control Device Operation Information

Type of Operation	Manually- Controlled	Pre-Timed	Actuated	Other (explain)
(please check one)				

- **Manually-Controlled:** The traffic control device will be operated at all times by an individual who will ensure the safe and efficient travel through the work zone.
- **Pre-Timed:** The traffic control device will operate automatically in a pre-determined timing pattern(s) based on time of day, and will continue to operate that way throughout the day.
- **Actuated:** The traffic control device will operate using sensors and will change green time as traffic demand warrants.
- **AFAD:** The traffic control device will be operated at all times by an individual(s) who will ensure the safe and efficient travel through the work zone.
- **Other (explain):** Other applications that do not fall into the criteria listed above. Please give a detailed description so that proper evaluation may be made.
- **PennDOT Publication Figure:** the determination of the correct figure to be followed from PennDOT Publication 213.
- **All-red clearance time:** This is to ensure that the proper clearance time is being used when using a temporary traffic signal. This should be determined by using the charts specified on the appropriate Publication 213 figure.



EXAMPLE PROBLEM
**APPLICATION FOR PERMIT TO OPERATE
 TEMPORARY TRAFFIC CONTROL SIGNALS**

Applicant's Contact Information

Applicant's Name: John Smith

Applicant's Company: Smith Contracting Company, Inc.

Company Address: 400 North Street Harrisburg, PA 17120

Company Phone No.: (717) 783-0333 Company Fax No.: (717) 705-0686

Cellular Phone No.: (717) 783-0555 E-mail Address: jsmith@smithcontracting.com

Name of Emergency Contact Person: James Smith Cellular Phone No.: (717) 777-5555
(Must be available 24 hrs./day, 7 days/week during period of usage.)

Description of Traffic Control Device

Type of Device (check one)	Mounted on Fixed Supports	Trailer-Mounted	Pedestal-Mounted	Automated Flagger Assistance Device (AFAD)	Other (explain)
<input checked="" type="checkbox"/>	<input type="checkbox"/>	<input type="checkbox"/>	<input type="checkbox"/>	<input type="checkbox"/>	<input type="checkbox"/>

Traffic Control Device Manufacturer: Traffic Control Signals, Inc. Manufacturer's Model No.: TCS1

PennDOT Approval No.: TCS-001P

Work Zone Information

Was a site visit performed prior to submitting this application? Yes X No

Date of Traffic Control Device Usage: Begin 06/10/2008 End 6/12/2008

Engineering District: 8-0 County: Dauphin Municipality: Lower Paxton Twp.

On State Route (SR): 1023 Direction: North/Southbound

From: Segment: 40 Offset: 1000

To: Segment: 40 Offset: 1500

On Local Road: N/A Direction: N/A

From: N/A

To: N/A

Normal Speed Limit: 35 mph ADT: 3,500 veh/day

Maximum Length of One-Lane, Two-Way Traffic Section 500 feet
(Between *STOP HERE ON RED* Signs)

Type of Operation: Long-Term Stationary _____ Short Term Stationary Non-Complex

Other (please describe): _____

The traffic control device will be used to control: One-Lane, Two-Way Traffic X
(Check all that apply) No More than Two approaches X
Other (please describe): _____

Will all signal faces exceed the thresholds for signal face visibility specified on the Publication 213 figure? Yes X No _____

Does the site contain an intersection within the one-lane, two-way traffic section? Yes _____ No X

Does the site contain an uncontrolled commercial driveway within the one-lane, two-way traffic section? Yes _____ No X

Is any roadway approach to the traffic control device on a steep downgrade (5% or more)? Yes _____ No X

Does the site contain an at-grade railroad crossing within 300 feet of the work zone? Yes _____ No X

Proposed work description:

Bridge patching project which consists of daylight operations. Upon completion of the day, two-lane, two-way operation will be restored.

Traffic Control Device Operational Information

Mode of Operation	Manually-Controlled	Pre-Timed	Actuated	Other (explain)
(please check one)			X	

PennDOT Publication Figure: PATA 26e NC-1 will be followed.

All-red clearance time is 23 seconds based on assumed traffic speed of 15 mph within one-lane, two-way section.

The proposed minimum green time shall be at least 10 seconds.

The proposed maximum green time shall be determined based on field conditions.

The proposed yellow change interval shall be five (5) seconds unless otherwise indicated by PennDOT.

Applicant Certification

The applicant certifies that the information provided on this application and accompanying documents is true and correct.

The applicant certifies that, if approved, the traffic control devices will be operated and maintained in compliance with PennDOT Publications 212 and 213, and the provisions of the temporary traffic control signal permit as issued by PennDOT.

The applicant agrees that it will indemnify, save harmless and defend (if requested) the Commonwealth of Pennsylvania, its agents, representatives and employees, from all suits, actions or claims of any character, name or description, damages, judgments, expenses, attorneys' fees and compensation arising out of personal injury, death or property damage, sustained or alleged to have been sustained in whole or in part by any and all persons whatsoever as a result of or arising out of any act, omission, neglect or misconduct of the applicant, its officers, agents, contractors or employees, during the period of temporary traffic control signal usage.

BY: _____
Signature of Applicant
Date

Sworn before me this _____ day of _____, 20_____

Notary: _____

Guidelines for the Selection of Temporary Traffic Control Signals in Work Zones

Background

It is common for construction, maintenance, and utility operations to require the closing of a traffic lane during the course of their work. For the duration of the lane closure, traffic must be either diverted to another route via a detour, or merged into other lanes. When the lane closure is located on two-lane, two-way roadways and detour routes are not practical, then alternating traffic on the remaining open lane is the typical operational choice.

Purpose

The purpose of these guidelines and the accompanying selection chart are to provide guidance for selecting the appropriate temporary traffic signal control for short-term and long-term lane closures on two-lane, two-way roadways. These guidelines supplement PennDOT Publication 213 and assist in the determination of the minimum requirements for work zone traffic control for various traffic and roadway parameters. Definitions of terminology and distance charts for various parameters are also available in this document.

MUTCD Guidance on Temporary Traffic Control Signals

“Section 4D.20 Temporary Traffic Control Signals

Standard:

A temporary traffic control signal shall be defined as a traffic control signal that is installed for a limited time period. A portable traffic control signal shall be defined as a temporary traffic control signal that is designed so that it can be easily transported and reused at different locations.

Support:

A temporary traffic control signal is generally installed using methods that minimize the costs of installation, relocation, and/or removal. Typical temporary traffic control signals are for specific purposes, such as for one-lane, two-way facilities in temporary traffic control zones (see Chapter 4G), for a haul-road intersection, or for access to a site that will have a permanent access point developed at another location in the near future.

Standard:

Advance signing shall be used when employing a temporary traffic control signal.

A temporary traffic control signal shall:

- A. Meet the physical display and operational requirements of a conventional traffic control signal.*
- B. Be removed when no longer needed.*

- C. Be placed in the flashing mode when not being used if it will be operated in the steady mode within 5 working days; otherwise, it shall be removed.*
- D. Be placed in the flashing mode during periods when it is not desirable to operate the signal, or the signal heads shall be covered, turned, or taken down to indicate that the signal is not in operation.*

Guidance:

A temporary traffic control signal should be used only if engineering judgment indicates that installing the signal will improve the overall safety and/or operation of the location. The use of temporary traffic control signals by a work crew on a regular basis in their work area should be subject to the approval of the jurisdiction having authority over the roadway.

A temporary traffic control signal should not operate longer than 30 days unless associated with a longer-term temporary traffic control zone project.

For use of temporary traffic control signals in temporary traffic control zones, reference should be made to Section 6F.80.”

“Section 6F.80 Temporary Traffic Control Signals

Standard:

Temporary traffic control signals (see Section 4D.20) used to control road user movements through TTC zones and in other TTC situations shall meet the applicable provisions of Part 4.

Support:

Temporary traffic control signals are typically used in TTC zones such as temporary haul road crossings; temporary one-way operations along a one-lane, two-way highway; temporary one-way operations on bridges, reversible lanes, and intersections.

Standard:

One-lane, two-way vehicular traffic flow (see Chapter 4G) requires an all-red interval of sufficient duration for road users to clear the portion of the TTC zone controlled by the traffic control signals. Safeguards shall be incorporated to avoid the possibility of conflicting signal indications at each end of the TTC zone.

Guidance:

Where pedestrian traffic is detoured to a temporary traffic control signal, engineering judgment should be used to determine if pedestrian signals or accessible pedestrian signals (see Section 4E.06) are needed for crossing along an alternate route.

When temporary traffic control signals are used, conflict monitors typical of traditional traffic control signal operations should be used.

Option:

Temporary traffic control signals may be portable or temporarily mounted on fixed supports.

Standard:

The supports for temporary traffic control signals shall not encroach into the minimum required width of a "pedestrian access route" of 1200 mm (48 in) or an "alternate circulation path" of 900 mm (36 in).

Guidance:

Temporary traffic control signals should only be used in situations where temporary traffic control signals are preferable to other means of traffic control, such as changing the work staging or work zone size to eliminate one-way vehicular traffic movements, using flaggers to control one-way or crossing movements, using STOP or YIELD signs, and using warning devices alone.

Support:

Factors related to the design and application of temporary traffic control signals include the following:

- A. Safety and road user needs;*
- B. Work staging and operations;*
- C. The feasibility of using other TTC strategies (for example, flaggers, providing space for two lanes, or detouring road users, including bicyclists and pedestrians);*
- D. Sight distance restrictions;*
- E. Human factors considerations (for example, lack of driver familiarity with temporary traffic control signals);*
- F. Road-user volumes including roadway and intersection capacity;*
- G. Affected side streets and driveways;*
- H. Vehicle speeds;*
- I. The placement of other TTC devices;*
- J. Parking;*
- K. Turning restrictions;*
- L. Pedestrians;*
- M. The nature of adjacent land uses (such as residential or commercial);*
- N. Legal authority;*
- O. Signal phasing and timing requirements;*
- P. Full-time or part-time operation;*
- Q. Actuated, fixed-time, or manual operation;*
- R. Power failures or other emergencies;*
- S. Inspection and maintenance needs;*

- T. Need for detailed placement, timing, and operation records; and*
- U. Operation by contractors or by others.*

Although temporary traffic control signals can be mounted on trailers or lightweight portable supports, fixed supports offer superior resistance to displacement or damage by severe weather, vehicle impact, and vandalism.

Guidance:

Other TTC devices should be used to supplement temporary traffic control signals, including warning and regulatory signs, pavement markings, and channelizing devices.

The design and placement of temporary traffic control signals should include interconnection to other traffic control signals along the subject roadway.

Temporary traffic control signals not in use should be covered or removed.”

Key Terms and Definitions

Portable Traffic Control Signal- as defined in the MUTCD is a temporary traffic control signal that is designed so that it can be easily transported and reused at different locations. Types of portable signals are trailer-mounted and pedestal-mounted.

Temporary Traffic Control Signal on Fixed Supports – as defined in the MUTCD is a temporary traffic control signal that is temporarily mounted on fixed supports. They are typically constructed with span wires mounted on temporarily-installed poles.

Trailer-Mounted Portable Traffic Control Signal System – The system consists of two trailers, with each trailer having a vertical upright and a horizontal arm to accommodate the mounting of at least two signal heads.

Pedestal-Mounted Portable Traffic Control Signal System – The system consists of four units, with a pedestral-mounted signal head on each unit.

Automated Flagger Assistance Device (AFAD) – is a manually-controlled device operated by one or more individuals to safely stop and control traffic through a work zone.

Long-Term Stationary Operation – As defined in PennDOT Publication 213 is work that occupies a location more than 24 hours.

Short-Term Stationary Operation – As defined in PennDOT Publication 213 is work that occupies a location up to 24 hours.

Short-Term Stationary Operation for Temporary Traffic Control Signals – is defined as daylight work areas with work in active progress, emergency nighttime work areas with

work in active progress, or work areas of relatively short duration where work begins during daylight and continues in active progress during hours of darkness.

Long-Term Stationary Operation for Temporary Traffic Control Signals - is defined as all other stationary operations that do not meet the short-term stationary operation for temporary traffic control signals criteria.

Signal Phase – the right-of-way, yellow change, and red clearance intervals in a cycle that are assigned to an independent traffic movement or combination of movements.

Two-Phase Traffic Signal Operation – is defined as an operation when two different vehicle movements occur during the signal cycle. One-lane, two-way traffic control is often a two-phase operation assuming that additional phases are not needed for driveways and intersecting roads.

Multiple Phase Traffic Signal Operation – is defined as an operation when more than two vehicle movements occur during the signal cycle.

Traffic Signal Timing – the amount of time allocated for the display of a signal indication.

Yellow Change Interval – is the first interval following the green interval during which the yellow signal indication is displayed. It is used to warn traffic of an impending change in the right-of-way assignment. The duration of a yellow change interval shall be predetermined.

Red Clearance Interval – is an interval that follows a yellow change interval and proceeds the next conflicting green interval. It provides additional time before conflicting traffic movements, including pedestrians, are released. The duration of a red clearance interval shall be predetermined.

Temporary Traffic Control Signal Permit – is the PennDOT Engineering District Office acceptance that the proper documentation was received to ensure safe and effective use of temporary traffic control signals. This permit will allow proper use of the device in accordance with the provisions of the permit and PennDOT Publication 213.

Temporary Traffic Control Signal Application – is an application that allows the PennDOT Engineering District Office to obtain the minimum required information to ensure safe and efficient operation of the temporary traffic control signal.

Site-Specific Drawing – A drawing that clearly depicts the work zone and the anticipated operations. Typically, this is part of the Traffic Control Plan (TCP).

Performance Specification – Is the required product performance, which may include but is not limited to equipment, physical requirements, operational requirements, etc..

Manually-Controlled Portable Traffic Control Signal Operation – when a portable traffic control signal is being controlled manually.

Short-Term Portable Traffic Control Signal Operation under Blanket Permit – this allows a successful past user of portable signals to obtain agreement with PennDOT to provide notice of the placement of the portable signals with minimal documentation. Verification of the agreement between the user and PennDOT will be evaluated prior to approval of a blanket permit request.

Short-Term Stationary Portable Traffic Control Signal Operation for Non-Complex Conditions– the “non-complex” application will be verified through a number of physical and operational requirements that the site must meet to be considered. These checks allow PennDOT to verify safe and efficient use if installed properly.

Short-Term Stationary Portable Traffic Control Signal Operation for Complex Conditions– the “complex” application would be any short-term portable signal installation that does not meet the requirements for “non-complex” applications.

Short-Term Emergency Operation – An emergency application defined in PennDOT Publication 212.

Long-Term Portable Traffic Control Signal Operation – All physical and operational requirements should be part of the Traffic Control Plan.

Temporary Traffic Control Signal – as defined in the MUTCD is a traffic control signal that is installed for a limited time period. Temporary traffic control signals may be portable or temporarily mounted on fixed supports. Common types of temporary traffic control signals are signals mounted on span wire with temporary supports and trailer-mounted portable signals.

Work in Active Progress – Workers, other than flaggers, are present and are actively engaged in performing the necessary work.

Temporary Traffic Control Signals for Long-Term Stationary Operations

In the design phase of every project that will have temporary traffic signals, it is required that both installations on fixed supports and trailer-mounted portable traffic control signals always be considered before completing the design of the Traffic Control Plan (TCP). In some instances, trailer-mounted portable signals or installations on fixed supports can be used. On the other hand, in certain instances, installations on fixed supports may be preferable to trailer-mounted signals, or vice-versa, depending on the nature of the project, site conditions, traffic conditions, and other specific factors.

Before developing a TCP with temporary traffic signals, it is absolutely essential that the designer visit the proposed worksite beforehand. The site visit will enable the designer to evaluate various factors that will help in the determination of whether the TCP should permit both temporary signal design options, or one or the other. These factors include lateral clearance, trailer or pole placement, signal operation (phasing and timing), and

others. Please also note that pedestal-mounted portable traffic control signals will not be considered for long-term stationary operations.

To establish the proper and acceptable temporary traffic control signal within a work zone, the following criteria should be considered:

Long-Term Stationary Operation Using Trailer-Mounted Portable Traffic Control Signals:

Pros:

- Systems can be deployed quickly.
- Especially conducive to deployments for emergencies.
- Systems can be easily set up and taken down each day, or for multiple construction phases.
- Equipment can be reused on future projects.
- Equipment capable of being leased.
- Cost savings potential.
- Capable of wireless radio or hardwire interconnect.
- Commonly equipped with monitoring system for location, low battery status, and conflicts using website and/or cell phone paging.
- Commonly equipped with batteries that are solar recharging.
- Commonly equipped with solar panels, rechargeable batteries, and ability to run via commercial power.
- Wireless remote commonly available.

Cons:

- Arm length can sometimes affect signal head placement.
- Arm length affects number of signal heads that can be placed overhead.
- Trailer size and/or arm length in conjunction with physical features can sometimes limit adequate placement.
- Manufacturers have different operating systems.
- More susceptible to vandalism.
- Less appropriate for long-duration jobs on multilane, high-speed roadways.

Long-Term Stationary Operation Using Temporary Traffic Control Signals on Fixed Supports:

Pros:

- Desirable signal head placement can be achieved.
- More than two overhead signals can be erected.
- Less susceptible to vandalism.
- Pole placement sometimes may be easier to accommodate than trailers due to physical features.
- Fixed supports may be more desirable for long duration deployments.

- More appropriate for multilane approaches.
- Employs common traffic signal control equipment and operational features.

Cons:

- Inability to set up and take down each day.
- Less appealing for short-duration jobs or jobs with short-duration, multiple set-ups.
- Equipment and material availability is sometimes an issue.
- Less cost savings potential.

If the designer determines that only one temporary signal design option is justified for a particular project, then the TCP shall be prepared accordingly, and written documentation shall be maintained in the project file outlining the reasons for this determination. It would also be desirable to clearly indicate on the TCP that the other option will not be permitted for the project.

If the designer determines that trailer-mounted portable signals or installations on fixed supports would be acceptable, then the TCP should clearly show the exact design and operation of both alternatives so that additional plans from the contractor would not be necessary. The TCP should include the design of all anticipated needed features. For example, if platforms or other special features will be needed, their design and placement should be in the TCP. Engineering judgment should be used and documented to determine the safest and most efficient operation for the work zone.

Temporary Traffic Control Signals for Short-Term Stationary Operations

Before developing and/or determining your traffic control plan (TCP) using PennDOT Publication 213, it is absolutely essential that the user visit the proposed worksite beforehand. The site visit will enable the user to evaluate various factors that will help in the determination of whether the TCP should permit temporary signal (portable signal) options, or other traffic control methods such as flaggers. These factors include lateral clearance, trailer or pedestal placement, signal operation (phasing and timing), and others. Please also note that installations on fixed supports are not considered viable for short-term stationary operations because of the amount of time and materials needed for installation.

If the user determines that portable traffic control signals will be an option and would like to pursue that option, then a completed application shall be submitted to PennDOT's appropriate Engineering District Office. If the Engineering District Office agrees with the proposed usage, they will issue a temporary traffic control signal permit.

Appendix B

Appendix B
Temporary Barrier Deflection Distances Table

Name	Type	FHWA Acceptance Designation	Section Minimum Length	Tested Height	Shape	Tested * Deflection
NYSDOT	I-Beam	B-94	20 ft.	32"	F & NJ	4.2 ft.
Rockingham Precast	T-Shape Connector	B-42	12 ft	32"	F	3.8 ft
Easi-Set Industries	J-J Hook	B-52	12 ft.	32"	F & NJ	4.2 ft
Easi-Set Industries	J-J Hook	HSA-10	12 ft.	54"	F	4.2 ft.
Virginia DOT	Pin & Loop	B-54	20 ft.	32"	F	6.0 ft.
Ohio DOT	Pin & Loop	B-93	10 ft.	32"	F & NJ	5.5 ft.
Pennsylvania DOT	Plate	B-79	12 ft.	34"	F	8.4 ft.

* The deflection distances shown in this table resulted from controlled crash tests at a 25 degree impact angle. The severe impact angle crash test may not be representative of actual field conditions.

If you have questions contact the Bureau of Design, Highway Quality Assurance Division at (717) 787-5023 and ask for the Standards and Criteria Section.